



## ADHUNIK METALIKS LIMITED

(Adhunik Metaliks Limited was incorporated as Neepaz Metaliks Private Limited on 20th November 2001 under the Companies Act, 1956. The Company subsequently became a public limited company and received a fresh certificate of incorporation in the name of Neepaz Metaliks Limited with effect from 25<sup>th</sup> March, 2004. The name of the Company was further changed to Adhunik Metaliks Limited with effect from 9th August 2005.)

**REGISTERED OFFICE :** 14, N. S. Road, 2nd Floor, Kolkata-700 001, India. **Tel:** +91 33 22434355, 22428551; **Fax:** +91 33 22434355

**CORPORATE OFFICE :** 2/1A, Sarat Bose Road, Kolkata – 700020, India. **Tel:** +91 33 22890279, 22890280; **Fax:** +91 33 22890285;

**Compliance Officer:** Shri Sougata Sengupta, Company Secretary; **Website:** www.adhunikgroup.com ; **E-mail:** info@adhunikgroup.com

**PUBLIC ISSUE OF 2,70,27,027 EQUITY SHARES OF RS. 10 EACH (“EQUITY SHARES”) FOR CASH AT A PRICE OF RS. 37.00 PER EQUITY SHARE AGGREGATING TO Rs.10,000 LACS (“ISSUE”) BY ADHUNIK METALIKS LIMITED (“AML” OR “THE COMPANY” OR “THE ISSUER”), THE ISSUE COMPRISES A RESERVATION FOR EMPLOYEES OF 13,51,351 EQUITY SHARES OF RS. 10 EACH AND A NET ISSUE TO THE PUBLIC OF 2,56,75,676 EQUITY SHARES OF RS. 10 EACH (THE “NET ISSUE”).THE ISSUE WILL CONSTITUTE 29.62% of the FULLY DILUTED CAPITAL OF THE COMPANY AFTER THE ISSUE.**

### THE ISSUE PRICE IS 3.7 TIMES THE FACE VALUE .

In case of revision in the Price Band, the Bidding/Issue Period will be extended for three additional working days after revision of the Price Band subject to the Bidding/Issue Period not exceeding 10 working days. Any revision in the Price Band and the revised Bidding/Issue Period, if applicable, will be widely disseminated by notification to The Bombay Stock Exchange Limited (“BSE”) and the National Stock Exchange of India Limited (“NSE”) by issuing a press release, and also by indicating the change on the websites of the Book Running Lead Manager and at the terminals of the Syndicate.

The Issue is being made through the 100% Book Building Process wherein at least 50% of the Net Issue shall be allocated on a proportionate basis to Qualified Institutional Buyers (“QIBs”). 5% of the QIB Portion shall be available for allocation to Mutual Funds only and the remaining QIB Portion shall be available for allocation to the QIB Bidders including Mutual Funds, subject to valid Bids being received at or above the Issue Price. If at least 50% of the Net Issue cannot be allotted to QIBs, then the entire application money will be refunded. Further, upto 15% of the Net Issue shall be available for allocation on a proportionate basis to Non-Institutional Bidders and upto 35% of the Net Issue shall be available for allocation on a proportionate basis to Retail Individual Bidders, subject to valid Bids being received at or above the Issue Price. Further, up to 13,51,351 Equity Shares shall be available for allocation on a proportionate basis to the Employees, subject to valid Bids being received at or above the Issue Price

### RISKS IN RELATION TO THE FIRST ISSUE

This being the first issue of the Equity Shares of the Company, there has been no formal market for the Equity Shares of the Company. The face value of the Equity Shares is Rs. 10 (Rupees Ten Only) and the Issue Price is 3.7 times of the face value. The Issue Price (as determined by the Company in consultation with the Book Running Lead Managers, on the basis of assessment of market demand for the Equity Shares by way of Book Building) should not be taken to be indicative of the market price of the Equity Shares after the Equity Shares are listed. No assurance can be given regarding an active and/or sustained trading in the Equity Shares or regarding the price at which the Equity Shares will be traded after listing.

### GENERAL RISKS

Investments in equity and equity-related securities involve a degree of risk and investors should not invest any funds in this Issue unless they can afford to take the risk of losing their investment. Investors are advised to read the risk factors carefully before taking an investment decision in this Issue. For taking an investment decision, investors must rely on their own examination of the Company and the Issue including the risks involved. The Equity Shares offered in the Issue have not been recommended or approved by the Securities and Exchange Board of India (“SEBI”), nor does SEBI guarantee the accuracy or adequacy of this Prospectus. Specific attention of the investors is invited to section titled “Risk Factors” beginning on page vii of this Prospectus.

### ISSUER’S ABSOLUTE RESPONSIBILITY

The Company, having made all reasonable inquiries, accepts responsibility for and confirms that this Prospectus contains all information with regard to the Company and the Issue, which is material in the context of the Issue, that the information contained in this Prospectus is true and correct in all material aspects and is not misleading in any material respect, that the opinions and intentions expressed herein are honestly held and that there are no other facts, the omission of which makes this Prospectus as a whole or any of such information or the expression of any such opinions or intentions misleading in any material respect.

### LISTING

The Equity Shares of the Company are proposed to be listed at Bombay Stock Exchange Limited (“BSE”) (The Designated Stock Exchange) and National Stock Exchange of India Limited (“NSE”). The Company has received in-principle approvals from BSE & NSE for the listing of the Equity Shares, vide letters dated February 7, 2006 & February 10, 2006 respectively.

BOOK RUNNING LEAD MANAGERS		REGISTRAR TO THE ISSUE
<b>SBI CAPITAL MARKETS LIMITED</b> 202, Maker Tower “E”, Cuffe Parade, Mumbai – 400005 Tel: 91 22 22189166, Fax: 91 22 22188332 E-mail: aml.ipo@sbicaps.com Website: www.sbicaps.com	<b>KARVY INVESTOR SERVICES LIMITED</b> 46, Avenue-4, Street No. 1 Banjara Hills, Hyderabad – 500 034 Tel: (040) 23312454, 23320251-53 Fax: (040)-23374714 Website: www.karvy.com Email: mbd@karvy.com	<b>KARVY COMPUTERSHARE PRIVATE LIMITED</b> Karvy House, 46, Avenue 4, Street no. 1, Banjara Hills, Hyderabad – 500 034. Tel.: (040) 2331 2454 Fax.: (040) 2331 1968 E-mail: adhunikipo@karvy.com Website: www.karvycomputershare.com

### ISSUE PROGRAMME

<b>BID / ISSUE OPENS ON</b>	March 13, 2006	<b>BID / ISSUE CLOSES ON</b>	March 17, 2006
-----------------------------	----------------	------------------------------	----------------

## TABLE OF CONTENTS

<b>TITLE</b>	<b>PAGE NO.</b>
<b><u>Definitions and Abbreviations</u></b>	
<b><u>I. Risk Factors</u></b>	
1. Forward-looking Statements and Market Data	Vii
2. Risk Factors	Viii
<b><u>II. Introduction</u></b>	
1. Summary	1
2. The Issue	4
3. General Information	5
4. Capital Structure	13
5. Objects of the Issue	28
6. Terms of Issue	43
<b><u>III. About the Company</u></b>	
1. Industry Overview	56
2. Business Overview	74
3. History and Corporate Structure of the Company	104
4. Management	109
5. Our Promoter & Group Companies	121
6. Exchange Rates	147
7. Currency of Presentation	147
8. Dividend Policy	147
<b><u>IV. Financial Statement</u></b>	
1. Financial Information of the Company	148
2. Management's Discussion and Analysis of Financial Condition and Results of Operations	172
<b><u>V. Legal &amp; Other Information</u></b>	
1. Outstanding Litigations and Material Developments	189
2. Government and other Approvals	199
<b><u>VI. Other Regulatory and Statutory Disclosures</u></b>	
<b><u>VII. Issue Information</u></b>	
1. Issue Structure	223
2. Issue Procedure	225
<b><u>VIII. Main Provisions of the Articles of Association of the Company</u></b>	249
<b><u>IX. Other Information</u></b>	
1. List of Material Contracts and Documents for Inspection	285
2. Declaration	288

## DEFINITIONS AND ABBREVIATIONS

### Conventional / General Terms

Term	Description
“AML” or “the Company” or “our Company” or “Adhunik Metaliks Limited”	Adhunik Metaliks Limited, a public limited company incorporated under the Companies Act, 1956.

### Offering-Related Terms

Term	Description
Allotment	Unless the context otherwise requires, the allotment of Equity Shares pursuant to the Issue.
Articles/Articles of Association	Articles of Association of our Company.
Auditors	M/s S. R. Batliboi & Co., Chartered Accountants
Banker(s) to the Issue	State Bank of India, ICICI Bank Limited, Standard Chartered Bank and HDFC Bank Limited
Bid	An indication to make an offer during the Bidding Period by a prospective investor to subscribe to our Equity Shares at a price within the Price Band, including all revisions and modifications thereto.
Bid Amount	The highest value of the optional Bids indicated in the Bid cum Application Form and payable by the Bidder on submission of the Bid in the Issue.
Bid/Issue Closing Date	The date after which the Syndicate will not accept any Bids for the Issue, which shall be notified in an English national newspaper and Hindi national newspaper, both with wide circulation.
Bid cum Application Form	The form in terms of which the Bidder shall make an indication to make offer to subscribe to the Equity Shares and which will be considered as the application for issue and transfer of the Equity Shares pursuant to the terms of this Prospectus.
Bidder	Any prospective investor who makes a Bid pursuant to the terms of this Prospectus and the Bid cum Application Form.
Bidding/ Issue Period	The period between the Bid/ Issue Opening Date and the Bid/ Issue Closing Date inclusive of both days and during which prospective Bidders can submit their Bids.
Bid/ Issue Opening Date	The date on which the Syndicate shall start accepting Bids for the Issue, which shall be the date notified in an English national newspaper and Hindi national newspaper, both with wide circulation.
Board of Directors/Board	The board of directors of our Company or a committee constituted thereof.
Book Building Process	Book building route as provided in Chapter XI of the SEBI Guidelines, in terms of which Issue is being made.
BRLMs/ Book Running Lead Managers	Book Running Lead Manager to the Issue, in this case being SBI Capital Markets Limited and Karvy Investor Services Limited.
BSE	The Bombay Stock Exchange Limited formerly known as The Stock Exchange, Mumbai
Co-BRLM/Co-Book Running Lead Manager	Microsec Capital Limited (formerly known as “Microsec India Limited”)
CAN/ Confirmation of Allocation Note	Means the note or advice or intimation of allocation of Equity Shares sent to the Bidders who have been allocated Equity Shares after discovery of the Issue Price in accordance with the Book Building Process.
Cap Price	The higher end of the Price Band, above which the Issue Price will not be finalised and above which no Bids will be accepted.
Companies Act	The Companies Act, 1956 as amended from time to time.
Cut-off Price	Any price within the Price Band finalised by us in consultation with the BRLMs. A Bid submitted at Cut-off Price is a valid Bid at all price levels within the Price Band.
Depository	A depository registered with SEBI under the SEBI (Depositories and Participant) Regulations, 1996, as amended from time to time.
Depositories Act	The Depositories Act, 1996, as amended from time to time.
Depository Participant	A depository participant as defined under the Depositories Act.
Designated Date	The date on which the Escrow Collection Banks transfer the funds from the Escrow Account to the Issue Account, which in no event shall be earlier than the date on which the Prospectus is filed with the RoC.

Term	Description
Designated Stock Exchange	The Bombay Stock Exchange Limited
Director(s)	Director(s) of Adhunik Metaliks Limited, unless otherwise specified.
Draft Red Herring Prospectus	The Draft Red Herring Prospectus dated January 7, 2006 issued in accordance with Section 60B of the Companies Act, which does not have complete particulars of the price at which the Equity Shares are offered and the number of shares under the Issue. Upon filing with RoC at least three days before the Bid/Issue Opening Date it will become the Red Herring Prospectus. It will become a Prospectus upon filing with RoC after the determination of Issue Price.
Employee	A permanent employee or a Director (whole-time Director, part-time Director or otherwise) of the Company, who is an Indian National and is based in India, excluding any Promoter or member of the Promoter group. The permanent employees should be on the payroll of the Company as of February 27, 2006 and the Directors should be Directors on the date of the Prospectus. The Employee(s) may also be referred to as "Bidder(s) in the Employee Reservation Portion" in this Prospectus.
Employees Reservation Portion	The portion of the Issue, being 5% of the Issue size available for allocation to Employees.
Equity Shares	Equity shares of the Company of face value of Rs. 10 each, unless otherwise specified in the context thereof.
Escrow Account	Account opened with an Escrow Collection Bank(s) and in whose favour Bidders will issue cheques or drafts in respect of the Bid Amount when submitting a Bid.
Escrow Agreement	Agreement to be entered into among the Company, the Registrar, the Escrow Collection Bank(s), and the BRLMs for collection of the Bid Amounts and for remitting refunds, if any, of the amounts collected, to the Bidders.
Escrow Collection Bank(s)	The banks, which are clearing members and registered with SEBI as Banker to the Issue at which the Escrow Account will be opened in this case being HDFC Bank Ltd., ICICI Bank Ltd., Standard Chartered Bank & State Bank Of India.
FEMA	The Foreign Exchange Management Act, 1999, as amended from time to time, and the rules and regulations framed thereunder.
FII	Foreign Institutional Investor (as defined under the Securities and Exchange Board of India (Foreign Institutional Investors) Regulations, 1995) registered with SEBI under applicable laws in India.
First Bidder	The Bidder whose name appears first in the Bid cum Application Form or Revision Form.
Floor Price	The lower end of the Price Band, below which the Issue Price will not be finalised and below which no Bids will be accepted.
Indian GAAP	Generally accepted accounting principles in India.
Issue	Public issue of 2,70,27,027 Equity Shares at a price of Rs. 37.00 each for cash aggregating to Rs. 10,000 Lacs by the Company.
Issue Price	The final price at which Equity Shares will be allotted in terms of this Prospectus, as determined by the Company in consultation with the BRLM, on the Pricing Date.
Issue Account	Account opened with the Banker(s) to the Issue to receive monies from the Escrow Account for the Issue on the Designated Date.
Margin Amount	The amount paid by the Bidder at the time of submission of his/her Bid, being 10% to 100% of the Bid Amount.
Memorandum of Association	The memorandum of association of our Company.
Mutual Fund(s)	A mutual fund registered with SEBI under the SEBI (Mutual Funds) Regulations, 1996.
Net Issue	The Issue of Equity Shares other than Equity Shares included in the Employee Reservation Portion
NSE	National Stock Exchange of India Limited.
Non-Institutional Bidders	All Bidders that are not Qualified Institutional Buyers or Retail Individual Bidders and who have bid for an amount more than Rs. 100,000.
Non-Institutional Portion	The portion of the Issue being at least 38, 51, 351 Equity Shares available for allocation to Non-Institutional Bidders.
Non Resident NRI/ Non Resident Indian	A person resident outside India, as defined under FEMA. A person resident outside India, who is a citizen of India or a person of Indian origin and shall have the same meaning as ascribed to such term in the Foreign Exchange Management (Transfer or Issue of Security by a Person Resident Outside India) Regulations, 2000.
Pay-in Date	Bid/Issue Closing Date or the last date specified in the CAN sent to the Bidders, as applicable.
Pay-in-Period	(i) With respect to Bidders whose Margin Amount is 100% of the Bid Amount,

Term	Description
	the period commencing on the Bid/Issue Opening Date and extending until the Bid/Issue Closing Date, and
(ii)	With respect to Bidders whose Margin Amount is less than 100% of the Bid Amount, the period commencing on the Bid/Issue Opening Date and extending until the closure of the Pay-in Date, as specified in the CAN.
Price Band	The price band with a minimum price (Floor Price) of Rs. 37 and the maximum price (Cap Price) of Rs. 42.
Pricing Date	The date on which the Company in consultation with the BRLM finalises the Issue Price.
Promoters	<p><b>1. NATURAL PERSONS:</b></p> <ul style="list-style-type: none"> <li>• Mr. Jugal Kishore Agarwal</li> <li>• Mr. Ghanshyamdas Agarwal</li> <li>• Mr. Nirmal Kumar Agarwal</li> <li>• Mr. Mohanlal Agarwal</li> <li>• Mr. Mahesh Kumar Agarwal</li> <li>• Mr. Manoj Kumar Agarwal</li> </ul> <p><b>2. THE COMPANIES WHICH ARE PROMOTERS</b></p> <ul style="list-style-type: none"> <li>• M/s Sungrowth Shares &amp; Stocks Limited</li> <li>• M/s Mahananda Suppliers Limited</li> </ul>
Promoter Group	Please refer to the promoter group described on page no. 121 of this Prospectus under the head “Capital Structure”
Prospectus	The prospectus, to be filed with the RoC after pricing containing, <i>inter alia</i> , the Issue Price and the number of shares that is determined at the end of the Book Building Process, the Issue and certain other information.
Qualified Institutional Buyers or QIBs	Public financial institutions as specified in Section 4A of the Companies Act, FIIs, scheduled commercial banks, mutual funds registered with SEBI, multilateral and bilateral development financial institutions, venture capital funds registered with SEBI, foreign venture capital investors registered with SEBI, state industrial development corporations, insurance companies registered with the Insurance Regulatory and Development Authority, provident funds with minimum corpus of Rs. 25 Crores and pension funds with minimum corpus of Rs. 25 Crores.
QIB Portion	The portion of the Issue being up to 1,28,37,838 Equity Shares available for allocation to QIBs.
Registered Office of the Company	14, N. S. Road, 2 <sup>nd</sup> Floor, Kolkata-700 001, India
Registrar/ Registrar to the Issue	Karvy Computershare Private Limited
Retail Individual Bidders	Bidders who applies or bids for Equity Shares of or for a value of not more than Rs. 100,000.
Retail Portion	The portion of the Issue being at least 89,86,486 Equity Shares available for allocation to Retail Individual Bidder(s).
Revision Form	The form used by the Bidders to modify the quantity of Equity Shares or the Bid Price in any of their Bid cum Application Forms or any previous Revision Form(s).
RHP or Red Herring Prospectus	The Red Herring Prospectus dated March 01, 2006 issued in accordance with Section 60B of the Companies Act, which does not have complete particulars of the price at which the Equity Shares are offered and the size of the Issue. The Red Herring Prospectus will be filed with the RoC at least three days before the Bid/Issue Opening Date and will become a Prospectus after filing with the RoC after pricing and allocation.
RoC	Registrar of Companies, West Bengal situated at NIZAM PALACE, 2 <sup>nd</sup> MSO Building, 234/4, AJC Bose Road, Kolkata – 700 020.
SCRR	The Securities Contracts (Regulation) Rules, 1957, as amended from time to time.
SEBI	The Securities and Exchange Board of India constituted under the SEBI Act.
SEBI Act	The Securities and Exchange Board of India Act, 1992, as amended from time to time.
SEBI Guidelines	The SEBI (Disclosure and Investor Protection) Guidelines, 2000 issued by SEBI, as amended, including instructions and clarifications issued by SEBI from time to time.
Stock Exchanges	BSE & NSE.
TRS/ Transaction Registration Slip	The slip or document issued by any of the members of the Syndicate to a Bidder as proof of registration of the Bid.
U.S. GAAP	Generally accepted accounting principles in the United States of America.
Underwriters	The BRLM & members of the Syndicate.
Underwriting Agreement	The agreement among the BRLM, members of the Syndicate and the Company to be entered into on or after the Pricing Date.

Abbreviation	Full Form
ACIT	Assistant Commissioner of Income Tax
AS	Accounting Standards as issued by the Institute of Chartered Accountants of India
CAGR	Compounded Annual Growth Rate
CIF	Cost-Insurance-Freight
CIT	Commissioner of Income Tax
EGM	Extraordinary General Meeting
EPC	Engineering Construction and Procurement Contract
EPCG	Export Promotion of Capital Goods
EPS	Earnings per share
ETP	Effluent Treatment Plant
EXIM	Export Import
FAN	Financial Appraisal Note
FCNR Account	Foreign Currency Non-Resident Account
Financial year /fiscal / FY	Period of twelve months ended March 31 of that particular year, unless otherwise stated.
FIPB	Foreign Investment Promotion Board
FY/ Fiscal	Financial year/ Fiscal year
GDP	Gross Domestic Product
GoI	Government of India
GoO	Government of Orissa
HUF	Hindu Undivided Family
I.T. Act	The Income Tax Act, 1961, as amended from time to time.
IDC	Interest During Construction
IPICOL	Industrial Promotion and Investment Corporation of Orissa Limited
LC	Letters of credit
LIBOR	London Interbank Offered Rate
MCL	Microsec Capital Limited
MOU	Memorandum of Understanding
NAV	Net Asset Value
NBFC	Non-Banking Financial Company
NOC	No Objection Certificate
NRE Account	Non-Resident External Account
NRO Account	Non-Resident Ordinary Account
NSDL	National Securities Depository Limited
p.a.	per annum
P/E Ratio	Price/Earnings Ratio
PAN	Permanent Account Number
PCFC	Packing Credit in Foreign Currency
PLR	Prime Lending Rate
RBI	The Reserve Bank of India
RoNW	Return on Net Worth
SBICAP	SBI Capital Markets Limited
TTM	Trailing Twelve Month
UCP	Uniform Customs and Practice for Documentary Credits
VD	Vacuum Degassing
VISP	Visweswarya Iron and Steel Plant
WESCO	Western Electricity Supply Company of Orissa Limited

ABC	Architecture, Building and Construction
AC	Alternating Current
ACMA	Automotive Component Manufactures Association ACMA
AGM	Annual General Meeting of the shareholders of our Company
AOD	Argon Oxygen De-carbonization
ART	Automobiles, Railways and Transportation
AS	Accounting Standards as issued by the Institute of Chartered Accountants of India
BVPS	Book Value Per Share
CAGR	Compounded Annual Growth Rate
CCM	Continuous Casting Machine
CDSL	Central Depository Services (India) Ltd.

CPP	Captive Power Plant
CRIS INFAC	CRISIL Research and Information Services Ltd.
Cum	Cubic Meter
DG	Diesel Generator
DRI	Directly Reduced Iron
EAF	Electric Arc Furnaces
EGM	Extraordinary General Meeting
EPS	Earnings Per Equity Share
FA	Ferro Alloys
FA - 1	Phase I of the Ferro Alloys Project
FA - 2	Phase II of the Ferro Alloys Project
FBC	Fluidized Bed Combustion
FC	Ferro Chrome
FCNR	Account Foreign Currency Non Resident Account
FeSi	Ferro Silicon
FeMn	Ferro Manganese
FOB	Free on Board
FY / Fiscal	Financial year ending March 31
GIR Number	General Index Registry Number
GoI	Government of India
HNI	High Net worth individual
HR	Human Resource
HRSBG	Heat Recovery Steam Generating Boiler
HUF	Hindu Undivided Family
IF	Induction Furnace
IPO	Initial Public Offering
KL	Kilo Liters
Ksc	Kilogram per square centimeter
KVA	Kilo Volt Ampere
LC SiMn	Low Carbon Silicon Manganese
LP	Low Pressure
MBF	Mini Blast Furnace
MS	Mild Steel
MT	Metric Tons
MMPA	Million Metric Ton Per Annum
MTPA	Metric Ton Per Annum
MVA	Mega Volt Ampere
MW	Mega Watt (i.e. 1000 kilo watts)
NAV	Net Asset Value
NRE Account	Non Resident External Account
NOC	No-Objection Certificate
NRO	Account Non Resident Ordinary Account
NSDL	National Securities Depository Ltd.
OEM	Original Equipment Manufacturer
P & P Expenses	Preliminary and Preoperative Expenses
P/E Ratio	Price/Earnings Ratio
PAN	Permanent Account Number
RM	Rolling Mills
Rs.	Indian National Rupee
RONW	Return on Net Worth
SAF	Submerged Arc Furnaces
SI	Sponge Iron
SS	Stainless Steel
STG	Steam Turbine Generator/(s)
TAN	Tax Deduction Account Number
TPD/MTD	Metric Tons per day
TPH	Tons per hour
°C	Degree Celsius
1 Unit of Power	1 Kilo watt hour/1000 watt hour
1 Metric Ton	1000 Kilograms

### Technical terms relating to project

Term	Description
Kiln	A refractory lined cylindrical Vessel for Chemical reaction with heat exchange
Hoppers	Conical shaped device for loading material into kiln/furnace etc.
Conveyor gantries	Motorised moving belt on which material is loaded for transportation
EOT cranes	Electrical Overhead Travelling (EOT) crane used for the movement of heavy object within the building.
Wet scrap conveyor	Conveyor system for transporting wet material
Vibratory feeder with screen	Material feeding system which vibrates while feeding to screen for size wise segregation
Electrostatic precipitator	An air pollution control device used to remove particulates from an air stream by establishing an electric charge on the particles which then are attracted to an oppositely charged collector. Used especially in coal plants and refuse-fired electric generation facilities.
Cooling tower	A piece of equipment which is used to cool water which has been heated in an air conditioning or other system. The cooling is done by letting the warm water fall through the air or by spraying it through air. Cooling water is recirculated over and over, and water treatments are added in the cooling tower.
AC drive	Variable speed drive designed to control the speed of three phase AC induction motor
PLL automatic system	Phase-Locked Loop (PLL) configured with integrated circuits for automatic control of system
Steam Turbine generation (STG)	Power Generated by extracting the energy of dry pressurized superheated steam as mechanical movement.
HRSB boiler	Heat Recovery Steam Generating Boiler, used to generate steam from recycled heat Surface condenser An apparatus for condensing steam, especially the exhaust of a steam engine by bringing it into contact with metallic surface cooled by water or air
Ejector	A jet pump used for suction of air / steam
Slag	Vitreous materials containing impurities from the ore and forming on the surface of molten metals

## **RISK FACTORS**

### **FORWARD LOOKING STATEMENTS; MARKET DATA**

We have included statements in the Prospectus which contain words or phrases such as “will”, “aim”, “will likely result”, “believe”, “expect”, “will continue”, “anticipate”, “estimate”, “intend”, “plan”, “contemplate”, “seek to”, “future”, “objective”, “goal”, “project”, “should”, “will pursue” and similar expressions or variations of such expressions, that are “forward-looking statements”.

Actual results may differ materially from those suggested by the forward looking statements due to risks or uncertainties associated with our expectations with respect to, but not limited to, our ability to successfully implement our strategy, our growth and expansion, technological changes, exposure to market risks, general economic and political conditions in India which have an impact on the business activities or investments, the monetary and interest policies of India, inflation, deflation, unanticipated turbulence in interest rates, foreign exchange rates, equity prices or other rate or prices, the performance of the financial markets in India and globally, changes in domestic and foreign laws, regulations and taxes and changes in competition in the industry.

For further discussion of factors that could cause the actual results to differ, see the section entitled “Risk Factors” beginning on page viii of the Prospectus. By their nature, certain market risk disclosures are only estimates and could be materially different from what actually occurs in the future. As a result, actual future gains or losses could materially differ from those that have been estimated. Neither our Company nor the members of the Syndicate, nor any of their respective affiliates have any obligation to update or otherwise revise any statements reflecting circumstances arising after the date hereof or to reflect the occurrence of underlying events, even if the underlying assumptions do not come to fruition. In accordance with SEBI requirements, we and the BRLMs will ensure that investors in India are informed of material developments until such time as the grant of listing and trading permission by the Stock Exchanges.

Unless stated otherwise, the financial data in the Prospectus is derived from our unconsolidated financial statements prepared in accordance with the Indian GAAP included elsewhere in the Prospectus. Unless stated otherwise, references to consolidated financial information is to the consolidated financial information under Indian GAAP. At present our financial year commences on April 1 and ends on March 31. In the Prospectus, any discrepancies in any table between the total and the sums of the amounts listed are due to rounding off.

### **Use of Market Data**

Market/Industry data used throughout the Prospectus was obtained by us from our internal sources or other publicly available sources deemed reliable by us. The information contained in those publications has been obtained from sources believed to be reliable, but their accuracy and completeness are not guaranteed and their reliability cannot be assured.

## RISK FACTORS

*An investment in equity shares involves a high degree of risk. You should carefully consider all of the Information in this Prospectus, including the risks and uncertainties described below, before making an investment in our Equity Shares. To obtain a complete understanding of our Company, you should read this section in conjunction with the sections titled "Our Business" and "Management's Discussion and Analysis of Financial Condition and Results of Operations" on pages 74] and 172 of this Prospectus as well as the other financial and statistical information contained in the Prospectus. If the following risks actually occur, our business, results of operations and financial condition could suffer, and the price of the Equity Shares and the value of your investment in the Equity Shares could decline.*

### INTERNAL RISK FACTORS

#### Risks Relating To Our Business

1. **Inability to retain/attract senior management personnel may lead to sub-optimal performance**

The success of the Company depends upon its senior management and key personnel. The future performance of the Company will depend upon the continued services of these persons. In the event, the Company is not able to retain its senior management personnel or attract and retain new senior management personnel in the future, it may lead to an adverse impact on its business and results of operations.

**Management Perception:**

Human capital management is a key focus area in our Company. The competitive compensation and perquisites offered to our personnel, challenging roles to steer a growing integrated steel company will enable us to attract and retain new senior management personnel.

2. **Volatility in raw material prices may have a negative impact on the financial performance of the company:**

In the recent past, there have been wide fluctuations in the prices of critical raw materials such as iron ore, coal, coke etc both at domestic and international markets. Such fluctuations in prices of raw material and AML's inability to negotiate at optimum market rates may affect the profitability.

**Management Perception:** Our Project envisages steps to insulate ourselves against market uncertainties through backward and forward integration measures, acquisition of access to captive mines, power plants and coal washery etc. which will soften/neutralize the effect of volatilities in the market for raw materials.

3. **Non-availability/limited availability of raw materials may lead to disruption in the production schedule of the company:**

AML is exposed to possible unpredictability in the supply of raw materials, particularly iron-ore, coke and coal. Any market related adverse movement in the supply of any of the above raw material may lead to disruption of the production schedule. Lack of availability of other resources such as water, skilled manpower etc. may also affect the operations and the profitability of the Company.

**Management Perception:** Our plant is located at Sundergarh, Orissa and is in close proximity to major sources of ore and coal. Besides, our Company has also entered into agreements for supply of power & industrial gases and has been allotted captive coal mines by the Government of Orissa. Further, we also expect the allotment of iron-ore mines for our facilities to be finalized by the Orissa Government shortly.

Please refer to page 85 for details on the present and proposed sourcing arrangements for raw materials and utilities. Our Company already employs skilled manpower at its existing operations and can tap the large pool of manpower locally available. In view of the tie-ups, allotment of captive mines and the opportunity to buy from the market, we do not anticipate any shortfall in supply of raw materials and other utilities.

4. **The Company's top 10 customers account for a large portion of its total income**

The top 10 customers of the Company accounted for Rs. 13652.23 lakhs which represents approximately 53.03% of the total gross sales during the nine months ended December 31, 2005.

**Management Perception:**

The Company is in the process of widening its product range and has initiated marketing arrangements in order to broaden its client base so that the extent of dependence on the top 10 customers is lower, going forward.

5. **Auditors' Qualifications:**

As per the Auditors' Report for the nine months ended December 31, 2005, following are the material remarks/notes/qualifications (in the order mentioned therein):

- (i) "The internal control system for purchases of inventory needs to be further strengthened by formalizing documentation and system related to procurement and indenting."
- (ii) "There are two contracts of supply of Raw Materials pertaining to two directors against which there have been transactions amounting to Rs. 1.31 lacs during the period which was not been entered into the 301 register. The aforesaid transactions with the directors have been verified and the prices at which such transactions have been made are reasonable having regard to the prevailing market prices at the relevant time."
- (iii) "According to the information and explanations given to us, except for Rs. 29,87,276 no undisputed amounts payable in respect of provident fund, investor education and protection fund, employees' state insurance, income-tax, wealth-tax, service tax, custom duty, excise duty, cess and other undisputed statutory dues were outstanding, at the period end, for a period of more than six months from the date they became payable. Out of the above, the entire amount has been deposited as on the date of our report."

6. **Contingent Liabilities not provided for could adversely affect the financial affairs of the Company:**

As of December 31, 2005, the contingent liabilities, not provided for, are enlisted in the following table. If these contingent liabilities materialise, fully or partly, AML's financial condition could be adversely affected.

Particulars	Amount (Rs. in Lacs)
Claims against the Company not acknowledged as debt.	54.56
Outstanding Bank Guarantee and Letter of Credit for import of material	186.50
Corporate Guarantees issued to Banks on behalf of group companies	200.00
<b>Total</b>	<b>441.06</b>

**Management Perception:**

The above mentioned liabilities have arisen in the normal course of business and we believe that none of the above contingent liabilities will have any material impact on the financial position of the Company even if they were to materialize.

7. **No previous track record of dividend.**

The Company has not declared any dividend since inception.

**Management Perception:**

Our manufacturing units commenced commercial production since May 2003 and the Company has since been regularly expanding its capacity. Therefore our company has not declared dividends in spite of making profits and has retained the internal accruals for expansion of the plant.

8. **The Company is exposed to Foreign Exchange related risks**

The Company currently imports raw material of about Rs. 7,000 lakhs that is likely to increase on account of the subsequent increase in capacity utilization of various units, which subjects it to volatilities in the foreign exchange market. The fluctuations in foreign exchange rates might have an impact on the financial performance of the Company.

**Management Perception:**

We plan to export a significant portion of our production, which will help hedge the risks on account of foreign exchange and for the balance uncovered imports we plan to put in place a foreign currency risk mitigation policy and may opt for suitable hedging mechanisms.

9. **Unsecured loans availed by the Company may be payable on demand by lenders.**

The company has availed of unsecured loans aggregating to Rs. 656.50 Lacs, which are callable anytime. If the lenders call these loans, fully or partly, AML's financial condition could be adversely affected.

**Management Perception:**

Considering the volume of business and scale of operations in relation to the quantum of unsecured loans, our company does not foresee any problems in meeting any such contingency.

**Risks Related To The Expansion Project****10. Delay in allocation of captive mines of iron ore as well as delay in implementation of the project may adversely affect the profitability of the company**

Any delay in allocation of iron ore mines and hence extraction of the ore/coal for use will affect AML's operations and profitability. Likewise, any delay in implementation of the project will result in time and cost overruns.

**Management Perception:**

Our Company has already received allotment of coal blocks at Patrapara, Orissa as per letter No. 13016/33/2005-CA-I. The allotment of mining rights in respect of iron ore is at an advanced stage. IPICOL has already forwarded the Company's proposal to Government of Orissa for allotment of mines which in turn has been recommended by the latter to the Government of India for final allotment. As per the implementation schedule, a time frame of 27 months has been considered for commencement of commercial exploration of Captive Coal Mines and Captive Iron Ore Mines.

**11. Inability/delay in getting approvals required to set up and operate the proposed projects may lead to cost /time overruns:**

The company is yet to receive certain approvals or licenses required for the implementation of the project and the failure to obtain these in a timely manner or at all, may adversely affect our operations. The details of such approvals are as follows

- The Company has made an application dated 22<sup>nd</sup> June, 2005 for consent for emission/continuation of emission under section 21 of the Air (Prevention and Control of Pollution) Act, 1981 for period upto March 31, 2006. The consent is yet to be received.
- The Company has made an application in form IV for consent for beginning to make any new discharge/continuing discharge of sewage / trade effluent under section 25 or 26 of the Water (Prevention and Control of Pollution) Act, 1974. The consent is yet to be received.

**Management Perception:**

We have already obtained the key approvals for commencing implementation of the project for which resources are being raised in this Issue. The pending approvals are expected shortly. These approvals are of routine nature and we see no difficulty in obtaining them in due course of time.

**12. The Company has only recently commenced ordering for the plant & machinery**

The Company has not yet placed orders for a large part of the requisite plant & machinery for the project. Any delay in placing the order and consequent delay in delivery of plant and machinery will adversely affect the implementation schedule of project and may defer the commercial production. The cost of Plant & Machinery has been estimated at Rs. 28,056 Lacs which represent 64% of the total cost of the project.

**Management Perception:**

The cost of the plant & machinery has been estimated by United Consultants (India) Private Limited (a reputed metallurgical engineering consultant) and has assisted the Company in identifying the suppliers of the machinery. Quotations have already been received from a large number of such suppliers and purchase orders are proposed to be placed in tandem with the project implementation schedule. Purchase orders/Letters of Intent for purchase of plant & machinery for an amount of approximately Rs. 2,900 Lacs have already been placed.

**13. The success of the current project would be dependent upon the project management skills of the existing management of the Company**

The company has embarked upon a Rs. 43736 Lacs project, which is large in comparison to its current size of operations of the Company. Although the promoters have an experience in the Steel industry, their competence in handling a project of this magnitude remains to be demonstrated.

**Management Perception:**

The promoter directors of the Company are first generation entrepreneurs and have established a presence for the Group in the areas of trading and processing of various metals and alloys. After garnering experience and knowledge of the sector, the promoters entered into manufacturing activities in the year 1992 by setting up their first corporate venture being Adhunik Steel Limited. The turnover of our group was more than Rs 534 Crores during the financial Year 2004-05. The Promoters of AML have established a track record of successful project management in timely commissioning of a Rs. 25,000 Lakhs steel plant in the Company. Moreover our company has already recruited highly qualified and experienced technocrats who have experience in setting up and running of similar projects.

**14. Critical risk factors/weaknesses/threats as per the Appraisal Report of SBI Capital Markets, Project Advisory and Structured Finance Group.**

- a. The company's plant is located at a distance of approximately 450 kms from the nearest port, which leads to higher transportation costs for imported raw materials.

**Management Perception:** AML is currently importing coke for its MBF division and is not facing any problem in its transportation. Further, once the private railway siding becomes operational, the transportation cost will be rationalized.

- b. The company is yet to develop a proper management information system commensurate with its scale of operations.

**Management Perception:** The company is in the process of implementing an ERP system (SAP).

- c. The steel industry has been highly volatile, and though it has bounced back smartly from the brink of collapse early in this century, the future continues to remain uncertain. With additional capacities coming up, only the players with competitive edge would be able to survive in the long run.

**Management Perception:** The promoters have planned cost reduction on one hand and value addition on other hand at all stages of production cycle. Moreover, the company's final product range does not classify it as a merchant steel manufacturer as a result of which it is not subject to the uncertainties in the steel market. Hence, the unit should be able to make sufficient value additions to absorb any temporary price fluctuations in the market, both domestic as well as global.

- d. The costs of raw materials are witnessing upward trend in the recent times. Any downward movement in the sale price of finished goods without proportionate reduction in the raw material prices will have a bearing on the viability of the unit.

**Management Perception:** With Captive Iron Ore and Coal mining, the unit will be immune to a large extent from volatility in the raw material prices. Till the time mines come into production, the unit has firm linkage for procurement of major raw materials.

- e. In the recent times, there has been a substantial capacity creation in the steel industry and a rapid pace of capacity creation may put the industry under stress leading to lower capacity utilization and poor realization.

**Management Perception:** AML has decided to mainly manufacture specialized value added alloy and stainless steel products. There are not many players in this market segment. Further, the pace of growth of demand of these products is enough to absorb increased capacities.

- f. AML needs to make arrangements for co-ordination of the project implementation in such a manner that the project is completed within the time frame envisaged.

- g. The company needs to obtain necessary statutory clearances

**15. Disbursement of term loans for the project is contingent upon the success of the Issue**

One of the terms and conditions for disbursement of the term loans is contingent on the satisfaction of certain conditions such as raising of funds through Issue etc. In case there is a delay in complying with any of the conditions, the disbursement of funds may be delayed and in turn may adversely impact the project and the future profitability.

**16. Inability/delay in enhancing the working capital limits may affect the operations of the Company**

The Company has not yet entered into any tie-ups for working capital required for the proposed project.

**Management Perception:**

The existing working capital facilities sanctioned by various banks are sufficient for the existing operations of our company. For the additional facilities, bankers will be approached nearer to the completion of the project.

**Other Incidental Risks**

17. **There are certain legal proceedings against our Company, Promoters and Promoter group companies.**

The Company's Directors, Promoters and group companies are parties to certain legal proceedings initiated by or against such parties. These proceedings are pending at different levels of adjudication before various courts, tribunals, enquiry officers, and appellate tribunals. For more information regarding legal proceedings against the Directors, Promoters and group companies, see the section "Outstanding Litigation and Material Developments" beginning on page 189 of this Prospectus.

**List of Material litigation:**

*Relating to the Company*

- a) A public interest litigation has filed, challenging the permission granted by the Water Resources Department, Collector, Chief Engineer, Lift Irrigation Department and Executive Engineer, National Highways Division to our Company to take water through a pipeline from the lift irrigation project which was duly constructed by the State Government for a dairy farm irrigation and for irrigation of other agricultural land praying that the Company be directed not to draw water from the Lift Irrigation Project and to shift the pipes layed down.
- b) A suit has been instituted against our Company for declaration of right, title and interest over the suit Adi (embankment), permanent injunction restraining from lay pipeline over the suit Adi and mandatory injunction to pull down the pipe lines if the same is laid during the pendency of the suit.
- c) Suit for temporary injunction against our Company has been filed praying for restraining our Company from disturbing or cause hindrance to the water supply system of the Shiba Ram Water & Sanitation Committee due to the laying of water pipelines in close proximity of that of Shiba Ram Water & Sanitation Committee.
- d) Our Company had entered into a contract dated July 28, 2005 for the purchase and import of low ash metallurgical coke of China origin from Express Well International Limited, certain dispute arose amounting to a claim of USD 2,70,00 out of the contract leading to Express Well International filing a arbitration petition under section 11(5) and 11(6) of the Arbitration and Conciliation Act, 1996 read with rule 2 of the Appointment of Arbitrator by the Chief Justice of India Scheme 1996 for the appointment of an Arbitrator before the Supreme Court of India on or about February 7, 2006.
- e) There are six cases with respect to statutory authorities comprising one case on entry tax and five excise cases.
  - Our Company had purchased goods like, support kiln, old used dumper, spare parts of 100 TPD kiln, clamping flange, cooler shell parts, gear ring etc for an amount of Rs 2,52,84,932.00/- and admitted entry @ 1% claiming the goods to purchased as scrap materials (machinery and spares). However the sales tax officer did not accept the submission since machinery and spares falls under Schedule-II of Entry Tax Act and hence are to be taxed @ 2%. Accordingly entry tax @ 2% was levied. The STO further added 5% on the purchase value towards freight charges. This lead to a dispute and the company filed an appeal before the ACST against the order of assessment under section 7(4) of the Orissa Entry Tax Act by the STO.
  - The following are the excise demands for irregular CENVAT credit and short payment of excise duty availed by our Company:

S.N.	DEMAND	PERIOD
1.	Rs 15,13,629	July 2003 to November 2003
2.	Rs 1402603 (Rs. 13, 75, 101/- of central excise duty and Rs 27,502 of education cess)	August 2004 to April 2005
3.	Rs 5,45,007/-	December 2003 to March 2004
4.	Rs 1,63,303	June 2004 to March 2004
5.	Rs 23,214	November 2004

*Relating to the Promoter Group:*

- M/s. Futuristic Steel Private Limited filed a stay petition against an order of a single bench of the High of Calcutta dismissing an application filed by M/s. Futuristic Steel Private Limited to restrain Orissa Manganese and Minerals Private Limited from affecting M/s. Futuristic Steel Private Limited right to purchase manganese ores agreed upon and granted by Orissa Manganese and Minerals Private Limited.

- Adhunik Steels Limited filed a special leave petition from order passed by the High Court of Orissa. Adhunik Steels Limited had moved the District Court of Sundergarh at Orissa, when the said court passed an order directing the parties to maintain status quo. Ultimately the district court vide its detailed judgment and order restrained the respondents from terminating the agreement or from dispossessing the petitioner. The respondents in the matter moved the High Court of Orissa against the aforesaid order. The High Court even though holding that the balance of convenience lied in favour of the petitioner did not affirm the judgment of the district court.
- Orissa Manganese and Minerals Private Limited has filed a special leave petition from order passed by the High Court of Orissa against Adhunik Steels Limited. This special leave petition was filed for allowing the petitioner to excavate, operate and manage the mines as the petitioners are the original lessees of the State Government of Orissa.

For further details please refer to page 189 of the Prospectus

18. **Interest of directors**

The following properties owned by Mr. Jugal Kishore Agarwal, Mr. Nirmal Kumar Agarwal and Mr. Ghanshyamdas Agarwal, promoter directors of the Company, have been leased out to the Company on the terms mentioned below. These promoter directors have an interest in these transactions to the extent of the lease paid to them for the said property.

Name of Director	Property Details	Mode of Interest	Lease Rent Payable (Rs. In lacs per annum)
Mr. Jugal Kishore Agarwal	Land measuring about 3.96 acres situated at Vill: Chadrihariharpur. Orissa	Given Lease to the Company for a period of 15 years commencing from 9 <sup>th</sup> August 2004	0.04
Mr. Nirmal Kumar Agarwal	Land measuring about 5.28 acres situated at Vill: Chadrihariharpur. Orissa	Given Lease to the Company for a period of 15 years commencing from 9 <sup>th</sup> August 2004	0.05
Mr. Ghanshyamdas Agarwal	Land measuring about 6.55 acres situated at Vill: Chadrihariharpur. Orissa	Given Lease to the Company for a period of 15 years commencing from 9 <sup>th</sup> August 2004	0.06

19. **Equity shares issued to promoters at par during the past twelve months**

The Company has issued 40,00,000 Equity Shares of Rs. 10/- each at par to the promoters as well as other shareholders of the amalgamating company on August 27, 2005 pursuant to Scheme of Amalgamation dated April 11, 2005 between Adhunik Metaliks Limited and Adhunik Minerals and alloys Limited.

20. **Some of the Companies in the Adhunik Group are operating in similar line of business.**

Adhunik Corporation Ltd., Adhunik Ispat Limited, Adhunik Alloys and Power Limited and Adhunik Steel Limited, group companies of Adhunik Metaliks Limited, are operating in the same industry segment and, among various products manufactured by them, are also manufacturing sponge iron and alloy steel billets. This could lead to a conflict of interest between these companies and Adhunik Metaliks Limited.

**Management Perception**

Adhunik Corporation Limited and Adhunik Ispat Limited, located at Durgapur, West Bengal are engaged in manufacture of steel viz, TMT bar, wire rod etc. for consumption in the construction segment. Adhunik Alloys and Power Limited has an exclusive tie-up with Tata Steel for supply of DRI on job work basis. Adhunik Steel Limited is a service provider to different steel companies.

Adhunik Metaliks Limited started its operations in the year 2003 by manufacturing Sponge Iron. The integrated steel plant has been set up in a phased manner so that every phase could generate revenues by itself. The present

expansion project will enable our Company to manufacture high value added products in steel specially suited for the automobile and engineering industry. Thus though the products currently being manufactured are similar to those being manufactured by some of the other companies within our group, the ultimate aim is to climb up the value chain. Moreover, the operations of the various companies within the group are situated at various locations and cater to different customers spread across various states. Hence our management does not foresee any conflict of interest arising with the other companies in the long run.

21. **Concentration of majority voting rights with the members of promoter group may lead to lopsided distribution of power**

Members of the Promoter group will continue to retain majority control in the Company after the Issue, which will allow them to influence the outcome of matters submitted to shareholders for approval. Upon completion of the Issue, members of the Promoter group will beneficially own approximately 7.36 % of the post-Issue equity share capital of the Company. As a result, the Promoter group will have the ability to exercise significant influence over all matters requiring shareholders' approval, including the election of directors and approval of significant corporate transactions. The promoter group will also be in a position to influence any shareholder action or approval requiring a majority vote, except where they are required by applicable laws to abstain from voting. Such a concentration of ownership may also have the effect of delaying, preventing or deterring a change in control.

**Management Perception:**

AML is a transparently managed Company where participative management is encouraged. Our Company expects to draw substantial entrepreneurial resources from our existing promoters who have demonstrated significant organizational and administrative capabilities over the past 10 years. The promoters along with our senior management personnel have been involved with critical functions like development of new products, marketing, and other operations of our Company. Our Company has inducted 3 independent directors on the board of the Company to broad base the Board, which would prevent the promoter group from taking actions that could adversely affect our Company and detrimental to the interests of the minority shareholders.

22. **Increasing capacities and intensifying competition in the steel industry may affect our prospects**

Large global steel majors and leading domestic steel companies are expected to set up sizable capacities in the country. The consequent increase in steel capacity and growing competition may lead to lower realizations and reduced margins for AML.

**Management Perception:**

The demand in the domestic as well as export market is sufficient to absorb the increased output from these new capacities for our product segment i.e. automotive steel, locomotive steel, engineering steel which cater to the demand of segments like Auto Ancillary sector/ OEMs, railways, defence and engineering sector. Considering the demand-supply position (as explained in the Section "Industry Overview"), the integrated nature of operations of the Company and the low cost of production, it is expected that we will be able to withstand market pressures.

23. **Loans and Advances to promoters/Group Companies**

The Company has provided Advances amounting to Rs. 176.11 Lacs as on December 31, 2005 to Promoters and Promoter Group Companies

24. **Losses incurred by group companies**

Losses incurred by some of the companies included in the Adhunik Group during the past three years upto FY 2005 are detailed below:

(Rs. In Lacs)

Name of the Company	FY 2003	FY 2004	FY 2005
Sungrowth Shares & Stocks Limited	-	-	0.07
Adhunik Steels Limited	-	21.49	-
MP Ispat & Power Pvt. Ltd.	-	-	0.16
Mahananda Suppliers Ltd.	0.29	-	-
Adhunik Metcoke Pvt. Ltd.	-	-	0.15
Adhunik Infotech Limited	-	-	4.45

**Management Perception:**

The above companies have been set up by our promoters for the purpose of entering into joint ventures with various state governments for mining of coal, iron-ore as well as to build up the presence of the group in this segment. No joint ventures have materialized till date and these ventures have not started yielding revenues.

25. **Restrictive Covenants of Banks/lenders may affect shareholders' rights**

The company is subject to usual and customary restrictive covenants in agreements that it has entered into with its banks or short-term loans and long-term borrowings. These restrictive covenants require the Company to seek the prior permission of the banks for various activities, including amongst others, alteration of the capital structure, raising of fresh capital, incurring expenditure on new projects, entering into any merger / amalgamation / restructuring, change in management etc. Accordingly, these restrictive covenants may affect some or all of the rights of its shareholders, including those mentioned on Page 43 of this Prospectus.

a

**Management Perception:**

h. Most of the covenants are standard in nature. Moreover, the promoters have obtained NOC from the various lending agencies to implement the expansion project.

26. **Industrial disputes and labour problems may lead to disruptions in operation**

The operations of the Company could be adversely affected by strikes, work stoppages or other industrial relations problems.

**Management Perception:**

There is no Trade Union in our Company. Over 80% of the employees are employed through Contractors, with whom we are having a contract renewable annually. Moreover considering the HR policy and cordial relationship with the employees our Company does not foresee any adverse effect in the our operations . During the operation period of last 3 years our Company has not lost any single man-day on account of Strike, Lockout or labour problem.

**EXTERNAL RISKS BEYOND THE CONTROL OF THE COMPANY:**

27. **Changes in Government Policies and political situation in India may have an adverse impact on the business and operations of the Company**

Since 1991, the Government of India has pursued policies of economic liberalization, including relaxing restrictions on the private sector. We cannot provide any assurance that the process of liberalization will be sustained in future. There could be a slowdown in the pace of economic development. The rate of economic liberalization could change, specific laws and policies could change, foreign investment, currency exchange rates and other matters affecting investing in our securities could change as well. Any adverse change in Government policies relating to the steel industry in general and stainless steel, sponge iron, Ferro alloys, iron ore in particular may have an impact on the profitability of the industry.

28. **Changes in the international demand –supply position for steel could impact the price of steel in both the international as well as domestic markets.**

China has been the largest consumer of steel in the year 2004 thereby acquiring a prominent position in the international scenario. Owing to the huge production capacities being built up in China, there is a possibility of China becoming self sufficient in steel thereby altering the Demand-Supply position. Such an event could bring down the international steel prices which in turn would also impact the domestic prices. This could further squeeze the profit margins of the players in this industry segment.

29. **The Company would face competition from the already established players in the high value added steel segment.**

Given the dominance of established players in the special and stainless steel market, the Company expects to face competition from existing players.

### **Management Perception**

On account of the cost efficiency envisaged in the production process of the company arising from the vertically integrated nature of operations of the Company, as a result of the implementation of the proposed project, the Company expects to emerge as one of the most price-competitive players in the special and stainless steel market and successfully cope with the threat of competitive pressures.

30. **After this Offer, the price of company's equity shares may be highly volatile, or an active trading market for its equity shares may not develop.**  
The prices of company's equity shares on the stock exchanges may fluctuate as a result of several factors, including:
- Volatility in the Indian and global securities market;
  - Company's results of operations and performance, in terms of market share;
  - Performance of its competitors in the Indian steel industry and the perception in the market about investments in the steel sector;
  - Changes in the estimates of its performance or recommendations by financial analysts;
  - Significant developments in India's economic liberalization and deregulation policies; and
  - Significant developments in India's fiscal and environmental regulations.
31. **There has been no public market for company's equity shares and the prices of it equity shares may fluctuate after this Offer.**  
There can be no assurance that an active trading market for company's equity shares will develop or be sustained after this Offer or that the Offer Price or the price at which it equity shares are initially traded will correspond to the prices at which it equity shares will trade in the market subsequent to this offering.
32. **Political, economic and social developments in India could adversely affect company's business.**  
Any change in regulations, domestic or international, having an impact on the steel market in general, will affect the industry as a whole. Such changes may be in the nature of introduction of quota, tariff barrier, subsidies etc.
33. **Statutory taxes and other levies may affect our margin in the event of our inability to factor such expense in our trading margin.**  
Any increase taxes and/ or levies, or the imposition of new taxes and/ or levies in the future, may have a material adverse impact on our business results of operations and financial condition.
34. **Terrorist attacks and other acts of violence or war involving India and other countries where the company sells its products could affect the company's business.**
35. **The Company is subject to risk rising from changes in interest rates and banking policy. The Company is dependent on various banks and financial institutions for arranging the Company's working capital requirements, term loans, etc. Accordingly, any change in the extant banking policy or increase in interest rates may have an adverse impact on the Company's profitability.**
36. **Any downgrading of India's debt rating by an international rating agency could have a negative impact on our business and could materially effect our future financial performance and the trading price of our equity shares.**

### NOTES:

- i) Present Issue of 2,70,27,027 equity shares of Rs. 10/- each for cash at a premium of Rs. 27.00 per share aggregating Rs. 10000 lacs.
- ii) The Net worth of the Company as on 31<sup>st</sup> December, 2005 is Rs. 11752.58 Lacs
- iii) The Book Value per equity share of face value of Rs. 10/- each as on 31<sup>st</sup> December, 2005 is Rs.18.30.

- iv) The average cost of acquisition of Equity Shares by the Promoters and Promoter Group is as below:

Promoter/member of Promoter Group	No. of Equity Shares	Average Acquisition Price (Rs./share)
Mahananda Suppliers Limited	24132300	13.68
Sungrowth Shares & Stock Limited	21467790	9.26
Nirmal Kumar Agarwal	1260500	8.69
Jugal Kishore Agarwal	1101000	9.05
Mahesh Kumar Agarwal	922410	9.52
Mohan Lal Agarwal	1168388	9.78
Manoj Kumar Agarwal	9960366	10.97
Ghanshyam Das Agarwal	547888	7.09

- v) For details of equity shares allotted to promoters during the past one year please refer to page no. 22 of this Prospectus.
- vi) Investors are advised to refer to the paragraph on “Basis for Issue Price” on page 45 before making an investment in the issue.
- vii) Investors may note that in case of over subscription, the allotment shall be on proportionate basis and for details; reference may be made to the Para “Basis of Allotment” given on page 242 of the Prospectus.
- viii) Investors may note that allotment and trading in shares of our Company shall be done only in dematerialized form.

Investors are free to contact the BRLM and the Compliance Officer for any clarification or information, who will be obliged to attend the same.

- ix) For Related party transactions, please refer page 162 under heading “Related Party transactions” of the Prospectus.
- x) Our Company was incorporated as a Private Limited Company on November 20, 2001. On March 25, 2004, it got converted into Public Limited Company. Subsequently our Company obtained a fresh certificate of incorporation on August 9, 2005 pursuant to the change of name from Neepaz Metaliks Limited to Adhunik Metaliks Limited. While there was no change in the business of the Company, since AML is the flagship of the Adhunik Group, the name of the Company was changed to Adhunik Metaliks Limited primarily to reflect this status and also to leverage the recognition of the Adhunik name. For further details please refer to the Chapter on “The History” on Page 104.
- xi) For details on Sale/purchase of securities by promoter group in the last 6 months , please refer to note no. 5 of the Capital Structure on page no. 24 of this prospectus.

## INTRODUCTION

### SUMMARY

*The Investor should read the following summary with the Risk Factors included from page numbers vii to xvii and the more detailed information about the Company and the financial statements included in the Prospectus.*

#### The Industry

One of the most useful and versatile material, steel is considered to be the backbone of human civilization. Increasing use of stainless steel is a barometer of the technical excellence of the steel industry and development of modern society. Among alternative materials, the versatility, durability and aesthetic quality of stainless steel make it a material of choice for the new millennium. There is no limit for use of stainless steel. Among steel categories, stainless steel is the most growth intensive. Considering the total world production during the period since 1960, while carbon steel has registered an annual growth rate of around 2-3 percent, stainless steel has registered an annual of growth rate of more than 6 percent. In India, its production in 1980-81 was only 66,000 tones and this has now reached above 7,60,000 tones at present. The impressive growth has been due to some of the following reasons:

- i. Increasing fascinations towards Kitchen utensils among the general public, due to its versatility. The kitchen utensils sector accounts for 76 per cent of the total consumption of stainless steel in India.
- ii. There has also been consistent growth in the non-utensil sector, particularly in:
  - a. Chemical and process industries
  - b. New and non-traditional applications like architecture building and construction (ABC)
  - c. The automobiles, railways and transportation sectors (ART)
  - d. Kitchen sinks, gas stoves and miscellaneous items growing over the years to dominate specific application areas.

#### Steel Production in India (in Million Tonnes):

Year	Main Producers	Secondary Producers	Grand Total
1991-92	7.96	6.37	14.33
1992-93	8.41	6.79	15.20
1993-94	8.77	6.43	15.20
1994-95	9.57	8.25	17.82
1995-96	10.59	10.81	21.40
1996-97	10.54	12.18	22.72
1997-98	10.44	12.93	23.37
1998-99	9.91	13.91	23.82
1999-00	9.37	16.29	25.66
2000-01	9.70	17.26	26.96
2001-02	11.46	18.98	30.44
2002-03	14.39	19.29	33.68
2003-04	15.12	21.00	36.12

*(Source: Industrial Development Services Pvt. Ltd., New Delhi)*

#### Business Overview

Our Company is a part of the Adhunik Group, having a larger presence in Eastern India and having manufacturing facilities in the states of West Bengal, Orissa, Jharkhand and Meghalaya. Our promoters have three decades of experience in the Iron & Steel industry. Our Company was incorporated in the year 2001 and we started our operations in the year 2003.

Our existing facilities are located at Chadrihariharpur, Sundergarh in Orissa. Presently we are operating five DRI units of 100 tpd capacity each in the Sponge Iron Division (Unit I) and have set up Steel Division (Unit II), which consists of a Blast Furnace Complex, one Electric Arc Furnace (EAF), one Ladle Refining Furnace and one Billet Caster.

The existing plant has been set up in a phased manner. We started our operations with Unit I in the year 2003 and Unit II was commissioned in the year 2005. We are also in the process of setting up a captive power plant under unit II. The plant is also equipped with a coal washery.

The capacity of billet casting plant is 2,50,000 MTs per annum of carbon and alloy steel billets. The capacities of various facilities which are a part of the Unit II are as under.

- 1 (one) no. 262 Cubic meters per day capacity Mini Blast Furnace (MBF) along with the auxiliary & balancing facilities.
- 1 (one) no. 35 M.T. batch capacity Electric Arc furnace, with adequate capacity of Transformer and breaker and all other auxiliary & balancing facilities.
- 1 (one) no. 6/11 M radius 2-strand continuous casting machine to cast billets of sizes ranging from 100 mm sq. to 200 mm sq.
- 2 x 400 SM<sup>3</sup> Oxygen Plant
- 12MW Captive Power Plant (CPP) as Cogeneration to DRI Units

All the facilities in the Unit II except Captive Power Plant (CPP) have already started the operations in phased manner. The Captive Power Plant is expected to commence operations by April 2006.

Our products adhere to high quality standards and our operations are ISO 9001 certified. This ensures that our products are consistently within the specification parameters provided by our customers. Driven by the growing demand of metaliks for steel production in the country, and after successful implementation of the initial phases of the project we have decided to set up an Integrated Steel Plant for production of high value added steel products to be utilized by the Auto industries and their ancillaries. With captive co-generation of power, private railway siding and captive mining rights, the venture is envisaged to be immune to steel cycle to the largest possible extent.

## SUMMARY FINANCIAL AND OPERATING INFORMATION

The financial statements given below should be read along with the Notes to the Accounts provided in the Auditors' Report on page No. 148 of this Prospectus and the para under the head "Management Discussion and Analysis" on page no. 172 of this Prospectus.

<b>STATEMENT OF ADJUSTED PROFITS AND LOSSES</b>					
					<i>Rs. In lacs</i>
Particulars	For the year / period ended 31st March				31st December
	2002 (20.11.01 to 31.03.02)	2003	2004	2005	2005 ( 9 months)
<b>Income</b>					
<b>Sales:</b>					
Of products manufactured by the Company (Net of Excise Duty)	-	-	2,508.08	9,369.09	9,501.27
Of products traded by the Company	-	-	830.51	2,382.57	11,637.55
Conversion Charges ( Net of Excise Duty)	-	-	-	1,166.78	2,775.90
Other Income	0.20	0.35	236.77	117.03	130.47
<b>Total Income</b>	<b>0.20</b>	<b>0.35</b>	<b>3,575.36</b>	<b>13,035.47</b>	<b>24,045.19</b>
<b>Expenditure</b>					
Raw Materials & Goods Consumed including expenses on conversion job	-	-	1,789.49	6,503.38	6,124.19
Decrease/ (Increase) in Inventories	-	-	(620.96)	132.34	(65.53)
Purchase of Trading Goods	-	-	790.66	2,218.98	10,302.65
Personnel Cost	-	-	22.28	126.54	228.54
Other Manufacturing Expenses	-	-	291.54	1,073.72	2,332.47
Administrative and other expenses	0.08	0.24	109.41	317.21	329.61
Selling and Distribution Expenses	-	-	288.01	1,076.26	646.70
Interest	0.04	-	103.65	298.99	649.55
Depreciation	-	-	73.72	220.73	438.34
Preliminary Expenditure written off	0.07	0.07	3.80	3.83	2.88
<b>Total Expenditure</b>	<b>0.19</b>	<b>0.31</b>	<b>2,851.60</b>	<b>11,971.98</b>	<b>20,989.39</b>
<b>Net Profit Before Tax and Extraordinary Items</b>	<b>0.01</b>	<b>0.04</b>	<b>723.76</b>	<b>1,063.49</b>	<b>3,055.79</b>
<b>Provision for Taxation:</b>					
Fringe Benefit Tax	-	-	-	-	6.48
Current Tax	-	0.02	55.64	88.26	257.15
Deferred Tax Liability / (Asset)	-	-	257.54	265.40	1,110.89
<b>Net Profit after tax and before Extraordinary Items</b>	<b>0.01</b>	<b>0.02</b>	<b>410.58</b>	<b>709.83</b>	<b>1,681.27</b>
Extraordinary Items (net of tax)	-	-	-	-	-
<b>Net Profit after Extraordinary Items</b>	<b>0.01</b>	<b>0.02</b>	<b>410.58</b>	<b>709.83</b>	<b>1,681.27</b>
Earlier Year adjustments	-	-	-	-	-
<b>Appropriations</b>					
Balance brought forward from previous year	-	0.01	0.03	410.61	1,120.44
Transfer to General Reserve	-	-	-	-	-
Proposed Dividend	-	-	-	-	-
Tax on Proposed Dividend	-	-	-	-	-
Balance carried to Balance Sheet	<b>0.01</b>	<b>0.03</b>	<b>410.61</b>	<b>1,120.44</b>	<b>2,801.71</b>

**Notes:**

(1) The above figures should be read with the Statement of Significant Accounting Policies and Statement of Notes on Adjusted Profits & Losses and Assets & Liabilities, as appearing in Annexure 4 and 5 respectively.

(2) Necessary adjustments have been made to the audited financial statements in accordance with the requirements of paragraph 6.10.2 of The Securities and Exchange Board of India (Disclosure and Investor Protection) Guidelines, 2000.

## THE ISSUE

### Public Issue of Equity Shares by the Company:

Which comprises :	
Issue:	2,70,27,027 Equity Shares.
Of which:	
Employee Reservation Portion	13,51,351 Equity Shares.
Net Issue	2,56,75,676 Equity Shares.
Of which:	
Qualified Institutional Buyers Portion:	At least 1,28,37,838 Equity Shares (allocation on proportionate basis).
Non-Institutional Portion:	Upto 38,51,351 Equity Shares (allocation on proportionate basis).
Retail Portion:	Upto 89,86,486 Equity Shares (allocation on proportionate basis).
Equity Shares outstanding prior to the Issue:	64,204,220 Equity Shares.
Equity Shares outstanding post the Issue	9,12,31,247 Equity Shares.
Objects of the Issue:	See the section titled “Objects of the Issue” on page 28 of this Prospectus.

#### Notes:-

- Employees of the Company eligible to apply under the reservation portion have an option to make an application under the “Net Offer” OR to apply under the Employee Reservation portion.
- Any undersubscribed portion in the Employee portion will be added back to the Net Issue.

## GENERAL INFORMATION

### ADHUNIK METALIKS LIMITED (Formerly known as Neepaz Metaliks Limited)

(Adhunik Metaliks Limited was incorporated as Neepaz Metaliks Private Limited on 20th November 2001 under the Companies Act, 1956. The company subsequently became a public limited company and received a fresh certificate of incorporation in the name of Neepaz Metaliks Limited with effect from March 25, 2004. The name of the company has been further changed to Adhunik Metaliks Limited with effect from 9th August 2005.)

#### REGISTERED OFFICE

: 14, N. S. Road, 2nd Floor, Kolkata-700 001, India.  
Tel: +91 33 22434355, 22428551; Fax: +91 33 22434355

#### CORPORATE OFFICE

: 2/1A, Sarat Bose Road, Kolkata – 700020, India.  
Tel: +91 33 22890279, 22890280; Fax: +91 33 22890285;

**Compliance Officer:** Shri Sougata Sengupta, Company Secretary;

**Website:** www.adhunikgroup.com ;

**e-mail:** info@adhunikgroup.com

**Company Registration Number 21-93945 of 2001**

**Address of the Registrar of Companies : Nizam Palace, 2<sup>nd</sup> MSO Buildings, 234/4, A. J. C. Bose Road, Kolkata – 700 020.**

#### BOARD OF DIRECTORS OF THE COMPANY

Name of the Director	Designation	Status
Mr. Ghanshyamdas Agarwal	Chairman	Non-Executive Director
Mr. Manoj Kumar Agarwal	Managing Director	Executive Director
Mr. Jugal Kishore Agarwal	Director	Non Executive Director
Mr. Nirmal Kumar Agarwal	Director	Non Executive Director
Mr. Mohan Lal Agarwal	Director	Non Executive Director
Mr. Mahesh Kumar Agarwal	Director	Non Executive Director
Mr. Supriya Gupta	Director	Non Executive Independent Director
Mr. Nihar Ranjan Hota	Director	Non Executive Independent Director
Mr. Lalit Mohan Chatterjee	Director	Non Executive Independent Director

#### BRIEF DETAILS OF THE CHAIRMAN AND THE MANAGING DIRECTOR

##### Mr. Ghanshyamdas Agarwal, Chairman

Mr. G. D. Agarwal (48 years) is a commerce graduate from Calcutta University. He has over 2 decades of experience in the steel sector. Mr. Agarwal pioneered the investment of the Group into Ferro Alloys by setting up a plant in Meghalaya under the aegis of Adhunik Meghalaya Steels (P) Limited. As the chairman of our Company he has been instrumental in defining the investment plans of the Company. His entrepreneurship has been awarded with prestigious 'Bharitya Udyog Ratan' by Indian Economic Development & Research Association, New Delhi in the year 2004.

##### Mr. Manoj Kumar Agarwal, Managing Director

Mr. M. K. Agarwal, son of Late Mahadeo Prasad Agarwal, aged about 36 years is an engineering graduate from REC Kurukshetra. He has more than a decade of experience in the steel industry. Being an engineer Mr. Agarwal has not only visualised the growth road map of the group but has also taken on himself to implement the projects in as per schedule. Under his leadership the Company has witnessed growth both in terms of setting up competitive manufacturing facilities and profitability. Mr. Agarwal has been a major influence in shaping up the future operation of the group and he has been responsible for the major steps taken by the company including a MoU entered into by the company with the Government of Orissa in respect of the mining leases for Coal and Iron ore. He has received the Scholar of Honour of

Outperformance Achievement award from the Institute of Indian Foundry Men, Jharkhand and has also been a Bharatiya Udyog Ratna Awardee during the year 2001.

**For details of Board of Directors, please refer Page 109 of this Prospectus.**

#### **COMPANY SECRETARY AND COMPLIANCE OFFICER**

**Mr. Sougata Sengupta**

##### **Adhunik Metaliks Limited**

'Lansdowne Towers', 2/1/A, Sarat Bose Road  
Kolkata - 700020  
Tel: 91 33 2289 0279 to 84  
Fax: 91 33 2289 0285  
E-mail: [ssengupta@adhunikgroup.com](mailto:ssengupta@adhunikgroup.com)

Note: Investors can contact the Compliance Officer in case of pre or post Issue related problems such as non-receipt of letters of allotment/share certificates/credit of securities in depositories beneficiary account/refund orders, etc.

#### **REGISTRAR TO THE ISSUE:**

##### **KARVY COMPUTERSHARE PRIVATE LIMITED**

Karvy House, 46, Avenue 4, Street No. 1,  
Banjara Hills, Hyderabad – 500034, India  
Tel: 9140 2343 1546  
Fax: 9140 2343 1551  
Website: [www.karvy.com](http://www.karvy.com)  
E-mail: [adhunik.ipo@karvy.com](mailto:adhunik.ipo@karvy.com)  
Contact Person: Mr. M. Murlikrishna

#### **LEGAL ADVISOR TO THE ISSUE**

##### **AMARCHAND & MANGALDAS & SURESH A. SHROFF & CO.**

Anand Lok, 227, A.J.C. Bose Road,  
Kolkata - 700020.  
Tel: 91 33 28650268  
Fax: 91 33 2247 2349  
E-mail: [am.kolkata@amarchand.com](mailto:am.kolkata@amarchand.com)

#### **AUDITORS**

M/s. S. R. BATLIBOI & CO.  
Chartered Accountants  
22, Camac Street, Block 'C', 3<sup>rd</sup> Floor,  
Kolkata - 700016.  
Tel: 91 33 2281 1224.  
Fax: 91 33 2281 7750.

#### **BANKERS TO THE ISSUE**

##### **State Bank of India**

New Issue & Securities Services Division,  
Mumbai Main Branch,  
Mumbai Samachar Marg, P B No. 13,  
Fort, Mumbai – 400 023.  
Tel: 91 22 22651579 / 22662133  
Fax: 91 22 22670745  
Contact Person: Smt. Anuradha Kurma

**Standard Chartered Bank Ltd.**

270, D.N. Road  
Fort  
Mumbai – 400 001  
Tel: 022 2209 2213  
Fax: 022 2209 4863  
Contact: Mr. Barhid Bhattacharya

**ICICI Bank Ltd.**

30 , Samachar Marg  
Fort Mumbai – 400 001  
Tel: 022-22655206  
Fax:022-22611138  
Contact: Siddharth Sankar Routray

**HDFC Bank Ltd.**

Corporate Banking Division  
B-6/3 Safdarjung Enclave  
Dda Commercial Complex  
Opp Deer Park  
New Delhi – 110 029  
Tel:011-51392100  
Fax:011-51652283  
Contact: Sumit Agarwal

**BANKERS TO THE COMPANY**

**State Bank Of India**

SSI Branch, Adityapur,  
Jamshedpur – 831 013  
Telefax: 91- 0657- 3092381

**State Bank of Mysore**

180 Rashbehari Avenue  
Kolkata – 700 029  
Tel: (033) 2464 0844  
Fax: (033) 2464 0624

**Punjab National Bank**

52A, Shakespeare Sarani,  
Kolkata 700017  
Telefax: (033) 22471738

**Indian Overseas Bank**

P-35, India Exchange Place, Kolkata 700001  
Tel: +91 33 22218690  
Fax: +91 33 22218690

**APPRAISING AGENCIES**

The project has been financially appraised by SBI Capital Markets Limited. The project has been technically appraised by United Consultants (India) Pvt. Ltd. For details please refer to paragraphs under “Objects of the Issue” on page no. 28 of this Prospectus.

**Disclaimer from Appraising Agency**

*“SBI Capital Markets Limited is not a monitoring agency for the above project and shall not be responsible in any way for utilization of the funds by the Company either temporarily or until deployment in the project/purposes stated*

*in the prospectus. Further, the permission to use our name in the prospectus shall not in any way cast any responsibility on us as regards compliance with various SEBI and other statutory rules, regulations and guidelines.”*

#### BOOK RUNNING LEAD MANAGERS (BRLMs)

##### **SBI Capital Markets Limited**

202, Maker Tower “E”,  
Cuffe Parade, Mumbai – 400005  
Tel: 91 22 22189166,  
Fax: 91 22 22188332.  
Contact Person: Mr. Debashish Ghoshal  
E-mail: aml.ipo@sbicaps.com  
Website: www.sbicaps.com

##### **Karvy Investor Services Ltd**

46, Avenue-4, Street No.1  
Banjara Hills, Hyderabad – 500 034  
Tel: (040) 23312454, 23320251-53  
Fax: (040)-23374714  
E-mail: mbd@karvy.com  
Contact person: Mr. T.R. Prashanthkumar  
(Hereinafter jointly referred to as the BRLMs)

#### CO-BOOK RUNNING LEAD MANAGER

##### **Microsec Capital Limited (Formerly known as Microsec India Limited)**

Azimganj House, 7, Camac Street  
Kolkata 700 017  
Tel: 033-22829330-4  
Fax: 033-22829335  
E-mail: adhunikipo@microsec.co.in  
Contact Person: Mr. Rakesh Sony

#### **Allotment of inter- se Allocation of Responsibility**

The responsibilities and co-ordination for various activities in this Issue to be carried out by the LM and the LMs are as under:

S.No	Activities	Responsibility	Co-ordinator
1.	Capital structuring with the relative components and formalities such as type of instruments etc.	SBI CAPS, Karvy	SBI CAPS
2.	Due diligence of the Company’s operations/management /business plans/legal etc.	SBI CAPS, Karvy	SBI CAPS
3.	Drafting and Design of the offer document and of statutory advertisement including memorandum containing salient features of the Prospectus. The designated Lead manager shall ensure compliance with stipulated requirements and completion of prescribed formalities with the Stock Exchanges Registrar of Companies and SEBI.	SBI CAPS, Karvy	SBI CAPS
4.	Drafting and approval of Issue and statutory publicity material, etc.	SBI CAPS, Karvy	SBI CAPS
5.	Drafting and approval of all corporate advertisement, brochure and other publicity material.	Karvy , SBI CAPS	Karvy
6.	Appointment of Registrar, Bankers and Advertising Agency	Karvy , SBI CAPS	Karvy
7.	Appointment of Printers	Karvy , SBI CAPS	Karvy
8.	Marketing of the Issue, which will cover inter alia,	SBI CAPS, Karvy	SBI CAPS

	<ul style="list-style-type: none"> <li>• Formulating marketing strategies, preparation of publicity budget</li> <li>• Finalize media &amp; PR strategy</li> <li>• Finalize centers for holding conferences for brokers, press, etc.</li> <li>• Finalize collection centers</li> <li>• Follow-up on distribution of publicity and issue material including application forms, PROSPECTUS and deciding on the quantum of the issue material.</li> </ul>		
9.	Finalizing the list of QIBs. Divisions of QIBs for one to one meetings, road show related activities and order procurement	SBI CAPS, Karvy	SBI CAPS
10.	Finalizing pricing and allocation.	SBI CAPS	SBI CAPS
11.	Post bidding activities including management of Escrow Accounts, co-ordination with Registrar and Banks, Refund to Bidders, etc.	SBI CAPS, MCL	MCL
12.	<p>The Post-issue activities of the Issue will involve essential follow-up steps, finalization of basis of allotment / weeding out of multiple application, etc. Major ones are :</p> <ul style="list-style-type: none"> <li>• Listing of securities</li> <li>• Dispatch of certificates and refunds</li> <li>• The various agencies connected with the work such as Registrars to the issue</li> <li>• Bankers to the issue and the bank handling refund business</li> </ul> <p>Lead Manager shall be responsible for ensuring that these agencies fulfill their functions and enable him to discharge this responsibility through suitable agreements with the issuer company</p>	SBI CAPS, MCL	MCL

#### SYNDICATE MEMBERS

##### **Karvy Stock Broking Ltd.**

"Karvy House", 46, Avenue 4,  
Street No.1, Banjara Hills,  
Hyderabad 500 034  
Tel: +91-40-23312454  
Fax No.: +91-40-23311968  
Contact Person: Mr. K. Sridhar

##### **Enam Securities Private Limited**

Khatau Building, 2<sup>nd</sup> Floor  
44 Bank Street  
Fort  
Mumbai – 400 023  
Tel: +91 22 2267 7901  
Fax: +91 22 22665613  
Contact Person: Mr. Ajay Sheth

##### **Edelweiss Securities Pvt. Limited**

14<sup>th</sup> Floor, Express Towers  
Nariman Point  
Mumbai – 400 021  
Tel: +91 22 2286 4206  
Fax: +91 22 2288 2119  
Contact Person: Mr. Bakul Mehta

#### CREDIT RATING

This being an Issue of Equity Shares, credit rating is not required.

#### TRUSTEE

This being an Issue of Equity Shares, appointment of Trustee is not required.

## **MONITORING AGENCY**

### **State Bank of India**

SSI Branch, Adityapur,

Jamshedpur – 831 013

**Telefax:** 91- 0657- 3092381

### **Book Building Process**

Book Building Process, with reference to the Issue, refers to the process of collection of Bids, on the basis of the Prospectus within the Price Band. The Issue Price is fixed after the Bid Closing Date.

The principal parties involved in the Book Building Process are:

- The Company;
- The Book Running Lead Manager;
- The Syndicate Member, who is an intermediary registered with SEBI or registered as a broker with NSE/ BSE and eligible to act as underwriters. The Syndicate Member is appointed by the BRLM; and
- The Registrar to the Issue.

The securities are being offered to the public through the 100% Book Building Process in accordance with the SEBI Guidelines wherein: (i) upto 50% of the Net Issue to the public shall be available for allocation on a proportionate basis to QIBs, of which 5% shall be available for allocation to mutual funds on proportionate basis and the remaining QIB portion shall be available for allocation to the QIB bidders including mutual funds (ii) not less than 35% of the Net Issue shall be available for allocation on a proportionate basis to Retail Individual Bidders, and (iii) not less than 15% of the Net Issue shall be available for allocation on a proportionate basis to the Non-Institutional Bidders subject to valid Bids being received at or above the Issue Price in accordance with the Prospectus.

In accordance with the provisions of the SEBI Guidelines, QIBs are not allowed to withdraw their Bid(s) after the Bid/ Issue Closing Date. For further details see section titled “Terms of the Issue” on page 43 of this Prospectus.

Our Company shall comply with the SEBI Guidelines and any other ancillary directions issued by SEBI for this Issue. In this regard, our Company has appointed SBI Capital Markets and Karvy Investor Services Limited as the Book Running Lead Managers to manage the Issue and to procure the subscriptions to the Issue.

The investors are advised to make their own judgment about investment through this process of Book Building prior to making a Bid.

### **Illustration of Book Building and Price Discovery Process**

(Investors should note that this example is solely for illustrative purposes and is not specific to the Issue)

Bidders can bid at any price within the price band. For instance, assume a price band of Rs. 20 to Rs. 24 per share, issue size of 3,000 equity shares and receipt of five bids from bidders out of which one bidder has bid for 500 shares at Rs. 24 per share while another has bid for 1,500 shares at Rs. 22 per share. A graphical representation of the consolidated demand and price would be made available at the bidding centers during the bidding period. The illustrative book as shown below shows the demand for the shares of the company at various prices and is collated from bids from various investors.

Bid Quantity	Bid Price (Rs.)	Cumulative Quantity	Subscription
500	24	500	27.77%
1000	23	1500	83.33%
1500	22	3000	166.67%
2000	21	5000	277.78%
2500	20	7500	416.67%

The price discovery is a function of demand at various prices. The highest price at which the issuer is able to issue the desired number of shares is the price at which the book cuts off i.e., Rs. 22 in the above example. The issuer, in consultation with the book running lead manager(s), will finalise the issue price at or below such cut-off price, i.e., at or below Rs. 22. All bids at or above this issue price and cut-off bids are valid bids and are considered for allocation in the respective categories.

#### Steps to be taken for Bidding:

1. Check eligibility for making a Bid (see section titled “Issue Procedure - Who Can Bid” on page 226 of this Prospectus);
2. Ensure that you have a demat account and the demat account details are correctly mentioned in the Bid cum Application Form.
3. If your Bid is for Rs. 50,000 or more, ensure that you have mentioned your PAN and attached copies of your PAN to the Bid cum Application Form (see section titled “Issue Procedure — ‘PAN’ or ‘GIR’ Number” on page 240 of this Prospectus).
4. Ensure that the Bid cum Application Form is duly completed as per instructions given in the Prospectus and in the Bid cum Application Form.

#### Underwriting Agreement

After the determination of the Issue Price and allocation of our Equity Shares but prior to filing of the Prospectus with the ROC, our Company will enter into an Underwriting Agreement with the Underwriters for the Equity Shares proposed to be offered through this Issue. It is proposed that pursuant to the terms of the Underwriting Agreement, the BRLM shall be responsible for bringing in the amount devolved in the event that the Syndicate Member does not fulfill its underwriting obligations.

The Underwriters have indicated their intention to underwrite the following number of Equity Shares:

Name, address, telephone, fax, email of the Underwriters	Indicative Number of Equity Shares to be Underwritten	Amount Underwritten (Rs in Crores)
SBI Capital Markets Limited 202, Maker Tower ‘E’, Cuffe Parade, Mumbai 400005	67, 56, 757	25.00
Karvy Investor Services Limited 46, Avenue-4, Street No.1 Banjara Hills Hyderabad – 500 034	67, 56, 657	25.00
Microsec Capital Limited Azimganj House	67, 56, 757	25.00

7 Camac Street Kolkata – 700 017		
Karvy Stock Broking Ltd. "Karvy House", 46, Avenue 4, Street No.1,Banjara Hills, Hyderabad 500 034	100	*0.00
Enam Securities Private Limited Khatau Building, 2 <sup>nd</sup> Floor 44 Bank Street Fort Mumbai – 400 023	33, 78, 378	12.50
Edelweiss Securities Pvt. Limited 14 <sup>th</sup> Floor, Express Towers Nariman Point Mumbai – 400 021	33, 78, 378	12.50

\* Negligible

*The above-mentioned amount is indicative and this would be finalized after determination of Issue Price and actual allocation of the Equity Shares. The above Underwriting Agreement is dated March 23, 2006.*

In the opinion of the Book Running Lead Managers and the Board of Directors (based on certificates dated January 9,2006 given to them by the BRLM and the Syndicate Member), the resources of the Underwriters are sufficient to enable them to discharge their respective underwriting obligations in full. All the above-mentioned Underwriters are registered with SEBI under Section 12(1) of the SEBI Act or registered as brokers with the Stock Exchanges. The above Underwriting Agreement has been accepted by the Board of Directors and our Company has issued letters of acceptance to the Underwriters.

Allocation among Underwriters may not necessarily be in proportion to their underwriting commitments. Notwithstanding the above table, the Underwriters shall be severally responsible for ensuring payment with respect to the Equity Shares allocated to investors procured by them. In the event of any default, the respective Underwriter in addition to other obligations to be defined in the Underwriting Agreement, will also be required to procure/ subscribe to the extent of the defaulted amount. Allocation to QIBs is on a proportionate basis as per the SEBI DIP Guidelines, 2000 and the terms of this Prospectus.

## CAPITAL STRUCTURE

Our share capital as at the date of filing of the Prospectus with SEBI (before and after the Issue) is set forth below:

*(Rs. In lacs, except share data)*

	<b>Aggregate nominal value</b>	<b>Aggregate Value at Issue Price</b>
<b>A. Authorised Capital<sup>1</sup></b>		
100000000 Equity Shares of Rs.10 each	10,000.00	-
<b>B. Issued, Subscribed and Paid-Up Capital before the Issue</b>		
64,204,220 Equity Shares of Rs.10 each	6,420.42	8871.930
<b>C. Present Issue in terms of this Prospectus</b>		
27,027,027 Equity Shares of Rs.10 each at a price of Rs. 37 per share	2702.70	10,000.00
Out of which:		
13,51,351 Equity Shares of Rs.10 each reserved for Employees on a competitive basis	135.14	500.00
Net Issue to the Public of 25,675,675 Equity Shares of Rs. 10 each at a price of Rs. 37.00 per share	2567.58	9,500.00
<b>D. Issued, subscribed and paid-up capital post the Issue</b>		
912,31,247 Equity Shares of Rs.10 each	9123.12	33755.56
<b>E. Share Premium Account</b>		
Prior to the Issue	2,451.51	
After the Issue	9748.81	

<sup>1</sup>The authorized share capital of our Company was increased from Rs. 10 lacs to Rs. 1 crore on March 30, 2002 through a resolution of the shareholders of the Company dated March 30, 2002, thereafter from Rs 1 crore to Rs.1.20 crores on January 30, 2003 through a resolution of the shareholders of the Company dated January 30, 2003, thereafter from Rs. 1.20 crores to 15.20 crores on October 6, 2003 through a resolution of the shareholders of the Company dated October 6, 2003, thereafter from Rs 15.20 crores to Rs.20 crores on January 5, 2004 through a resolution of the shareholders of the Company dated January 5, 2004, from Rs. 20 crores to 36 crores on February 18, 2004 through a resolution of the shareholders of the Company dated February 18, 2004 from Rs. 36 to Rs. to 60 crores on September 20, 2004 through a resolution of the shareholders of the Company dated September 20, 2004 from Rs. 60 crores to 75 crores on March 20, 2005 through a resolution of the shareholders of the Company dated March 20, 2005. The authorized capital was further increased from Rs 75 crores to Rs Rs. 100 crores on January 5, 2006 through a resolution of the shareholders of the Company dated January 5, 2006.

## NOTES TO THE CAPITAL STRUCTURE

### 1. Share Capital History of our Company:

The following is the history of the Equity Share Capital of our Company: -

Date of Allotment & Date on which fully paid-up	Number of Equity Shares (of face value of Rs. 10)	Issue Price (Rs.)	Consideration (cash, bonus, consideration other than cash)	Reasons for allotment (including persons to whom allotment was made)	Cumulative Share Premium (Rs.in lacs)	Cumulative Share Capital (Rs. in lacs)
November 22, 2001	20000	10	Cash	Subscription on signing of Memorandum of Association <sup>1</sup>	Nil	2.00
March 30, 2002	108540	100	Cash	Further allotment on private placement <sup>2</sup>	97.69	12.85
November 20, 2002	165000	100	Cash	Further allotment on private placement <sup>3</sup>	246.19	29.35
January 31, 2003	677500	100	Cash	Further allotment on private placement <sup>4</sup>	855.94	97.10
October 6, 2003	8545152	10	NA	Bonus issue in the ratio of 5:44 <sup>5</sup>	1.42	951.62
October 12, 2003	4545000	10	Cash	Shares issued to promoter <sup>6</sup>	1.42	1406.12
February 4, 2004	3788720	10	Cash	Further allotment on private placement <sup>7</sup>	1.42	1784.99
March 31, 2004*	840000	10	Cash	Further allotment on private placement <sup>8</sup>	1.32	1868.99
July 29, 2004	5900000	10	Cash	Further allotment on private placement <sup>9</sup>	1.32	2458.99
August 20, 2004	7605000	10	Cash	Further allotment on private placement <sup>10</sup>	1.32	3219.49
September 30, 2004	6660500	10	Cash	Shares issued to promoters and their relative <sup>11</sup>	1.32	3885.54
October 31, 2004	3350000	10	Cash	Shares issued to promoter <sup>12</sup>	1.32	4220.54
November 15, 2004	1000000	10	Cash	Shares issued to promoter <sup>13</sup>	1.32	4320.54
November 30, 2004	2250000	10	Cash	Shares issued to promoter <sup>14</sup>	1.32	4545.54
January 24, 2005	3100000	10	Cash	Further allotment on private placement <sup>15</sup>	1.32	4855.54
February 7, 2005	2195000	10	Cash	Further allotment on private placement <sup>16</sup>	1.32	5075.04
February 21, 2005	1100000	20	Cash	Further allotment on private placement <sup>17</sup>	111.32	5185.04
February 25, 2005	1800000	25	Cash	Further allotment on private placement <sup>18</sup>	381.32	5365.04

Date of Allotment & Date on which fully paid-up	Number of Equity Shares (of face value of Rs. 10)	Issue Price (Rs.)	Consideration (cash, bonus, consideration other than cash)	Reasons for allotment (including persons to whom allotment was made)	Cumulative Share Premium (Rs.in lacs)	Cumulative Share Capital (Rs. in lacs)
March 16, 2005	422260	60	Cash	Further allotment on private placement <sup>19</sup>	592.45	5407.27
May 2, 2005	740600	60	Cash	Further allotment on private placement <sup>20</sup>	962.75	5481.33
July 21, 2005	1068700	60	Cash	Further allotment on private placement <sup>21</sup>	1497.10	5588.20
August 27, 2005	4000000	10	Under Scheme of Amalgamation	Issued pursuant to Scheme of Amalgamation dated April 11, 2005 to the shareholders of Adhunik Minerals and Alloys <sup>22</sup>	1497.10	5618.20
October 15, 2005	300000	60	Cash	Shares issued to promoter <sup>23</sup>	1647.10	6020.42
December 31, 2005	4022248	30	Cash	New shares issued pursuant to private placement <sup>24</sup>	2451.55	6420.42

\* An amount of Rs. 10,236 has been adjusted against preliminary expenses in the profit & loss account.

- 1 Allotted to Jugal Kishore Agarwal, Ghanshyam Das Agarwal, Mahesh Kumar Agarwal, Manoj Kumar Agarwal.
- 2 Allotted to Lambodar Commercial Pvt. Ltd., Navilan Merchants Pvt. Ltd., Octal Commodities Pvt. Ltd., Raina Commodities Pvt. Ltd., Raina Commodities Pvt. Ltd., Raina Commodities Pvt. Ltd., Rasraj Sales Pvt. Ltd., Stanley Merchants Pvt. Ltd., Stanley Merchants Pvt. Ltd., Adhunik Ferro Alloys Pvt. Ltd., Mittal Management Pvt. Ltd.
- 3 Allotted to Citi Point Ltd., Finlord Marketing Pvt. Ltd., Sungrowth Shares & Stocks Ltd., Triline Vyapaar Pvt. Ltd.,
- 4 Allotted to Citi Point Ltd., Frankross Vinimay Limited, Hanuman Freight & Carriers (P) Ltd., Hanuman Forgings & Engg. Pvt. Ltd., Heaven Barter Ltd., Jb Tea Trading (P) Ltd., North West Coal Co. Ltd., Raina Vyapaar (P) Ltd., Shekhar Commerce (P) Ltd., Shri Vaikuntnath Trading (P) Ltd., Stephen Marketing Ltd., Sungrowth Shares & Stocks Ltd., Vijay Enclave Ltd., Vijay Greenfields Ltd.

5. Issue of Bonus Shares to :

Jugal Kishore Agarwal  
Navilan Merchants Pvt. Ltd.  
Lambodar Commercial Pvt. Ltd.  
Ghanshyam Das Agarwal  
Raina Commodities Pvt. Ltd.  
Octal Commodities Pvt. Ltd.  
Mahesh Kumar Agarwal  
Rasraj Sales Pvt. Ltd.  
Mittal Management Pvt. Ltd.  
Manoj Kumar Agarwal  
Stanley Merchants Pvt. Ltd.  
Adhunik Ferro Alloys Pvt. Ltd.  
Citi Point Ltd.  
Finlord Marketing Pvt. Ltd.  
Triline Vyapaar Pvt. Ltd.  
Sungrowth Shares & Stocks Ltd.  
Frankross Vinimay Limited  
Hanuman Freight & Carriers (P) Ltd.  
Heaven Barter Ltd.  
Jb Tea Trading (P) Ltd.  
North West Coal Co. Ltd.  
Raina Vyapaar (P) Ltd.  
Shekhar Commerce (P) Ltd.  
Shri Vaikuntnath Trading (P) Ltd.  
Stephen Marketing Ltd.  
Vijay Enclave Ltd.  
Vijay Greenfields Ltd.

6. Allotment made on 12-Oct-03

Sungrowth Shares & Stocks Ltd.

7. Allotment made on 4-Feb-04

Feel Good Merchandise Pvt. Ltd.  
Ghanshyam Das Agarwal  
Information Synergies Pvt. Ltd  
Jugal Kishore Agarwal  
Manoj Kumar Agarwal  
May Fair Trade Com. Pvt. Ltd.  
Mittal Management Pvt. Ltd.  
Mohanlal Agarwal  
North West Coal Co. Ltd.  
Rovam Tie Up Pvt Ltd  
Shresth Consultancy Private Limited  
Sumantha Trading & Commission Pvt. Ltd  
Sungrowth Shares & Stocks Ltd  
Vijay Enclave Ltd.  
Vijay Greenfields Ltd.

8. Allotment made on 31-03-2004

Aakask Nidhi  
Aakriti Nidhi  
Akanksha Nidhi  
Annapurna Sharaff  
Chirag Nidhi  
Frankross Vinimay Limited  
Guddu Sharaff  
Kanchan Commodeal P. Ltd.  
Mahananda Suppliers Ltd.  
Mahesh Kumar Agarwal  
Malvika Nidhi  
Mayanak Nidhi  
Nirmal Kumar Agarwal  
Pathik Agencies Pvt. Ltd.  
Shringar Marketing P. Ltd.  
Sitaram Sharaff  
Vaivhav Nidhi  
Vibhore Trading & Finance Ltd.

9. Allotment made on 29-July-2004

Anita Agarwal  
Chandrakanta Agarwal  
Ekta Agarwal  
Ghanshyam Das Agarwal  
Jugal Kishore Agarwal  
Mahesh Kumar Agarwal  
Meena Agarwal  
Mohan Lal Agarwal  
Naveen Kumar Agarwal  
Nirmal Kumar Agarwal  
Permila Agarwal  
Rita Agarwal  
Sachin Kumar Agarwal  
Smita Agarwal  
Sonika Agarwal  
Sungrowth Shares & Stocks Ltd.

10. Allotment made on 20-August-2004

Manohar Management Limited  
Sungrowth Shares & Stocks Ltd.

11. Allotment made on 30-September-2004

Anita Agarwal  
Chandrakanta Agarwal  
Ekta Agarwal  
Ghanshyam Das Agarwal

Jugal Kishore Agarwal  
Mahananda Suppliers Ltd.  
Mahesh Kumar Agarwal  
Meena Agarwal  
Mohan Lal Agarwal  
Naveen Kumar Agarwal  
Nirmal Kumar Agarwal  
Permila Agarwal  
Rita Agarwal  
Sachin Kumar Agarwal  
Smita Agarwal  
Sonika Agarwal

12. Allotment made on 31-October-04

Mahananda Suppliers Limited

13. Allotment made on 15 November, 2004

Mahananda Suppliers Limited

14. Allotment made on 30 November, 2004

Mahananda Suppliers Limited

15. Allotment made on 24-01-2005

Dolphin Infotech Limited  
Information Synergies Pvt. Ltd  
Mahananda Suppliers Ltd.  
Shri Vaikuntnath Trading (P) Ltd

16. Allotment made on 07-February-2005

Ghanshyamdas Agarwal(Huf)  
Information Synergies Pvt. Ltd  
Mahananda Suppliers Ltd.  
Nirmal Kumar Agarwal  
Sachin Kumar Agarwal

17. Allotment made on 21-February-2005

Mahananda Suppliers Ltd.

18. Allotment made on 25-February-2005

Adhunik Meghalaya Steels Pvt. Limited  
Adhunik Meghalaya Steels Pvt. Limited  
Mahananda Suppliers Limited  
Mahananda Suppliers Ltd.

19. Allotment made on 16-March-2005

Chandrakanta Agarwal  
Ekta Agarwal  
Mahadeo Prasad Agarwal(Huf)  
Mahananda Suppliers Ltd.  
Smita Agarwal

20. Allotment made on 02-May-2005

Adhunik Ferro Alloys Pvt. Ltd  
Adhunik Steels Ltd  
Mahananda Suppliers Ltd.  
Manoj Kumar Agarwal  
Mohan Lal Agarwal  
Nirmal Kumar Agarwal

21. Allotment made on 21-July-2005

Adhunik Steels Ltd  
Mahananda Suppliers Limited  
Neepaz Tube Pvt. Ltd

22. Allotment made pursuant to Scheme of Amalgamation on 27-August-2005

Jugal Kishore Agarwal  
L. M. Chatterjee  
N. Mittal  
Manoj Kumar Agarwal  
Mahesh Kumar Agarwal  
Mohan Lal Agarwal  
Ghanshyam Das Agarwal  
K D Jag Holding Pvt. Ltd  
Adhunik Ferro Alloys Ltd.  
Shresth Consultancy Private Limited  
Information Synergies Pvt. Ltd  
Vijay Greenfields Ltd.  
Stephen Marketing Ltd.  
Rovam Tieup Pvt. Ltd  
Devasya Distributors Pvt. Ltd.  
Falcon Trading Pvt. Ltd  
Bunty Investments Pvt. Ltd.  
Rajdarshan Commodities Pvt. Ltd.  
Shubh Suppliers Pvt. Ltd.  
Simpro Vanijya Pvt. Ltd.  
Vishav Dealers (P) Ltd.  
Sungrowth Shares & Stocks Ltd.  
Anita Agarwal  
Chandrakanta Agarwal  
Ekta Agarwal  
Meena Agarwal  
Mohan Lal Agarwal  
Nirmal Kumar Agarwal  
Rita Agarwal  
Murli Management Limited  
Manohar Management Limited

23. Allotment made on 15-October-2005

Mahananda Suppliers Limited

24. Allotment made on 31-December-2005

Adit G Mehta  
Arena Textile & Industries Limited  
Gladstone Agencies Limited  
Hexagram Investment Pvt. Ltd.  
Janaki Textile & Industries Limited  
Kautilaya Advertising Pvt. Ltd.  
Meenakshi Mercantile Limited  
Nibedan Sales Pvt. Ltd.  
Paragon Finance Limited  
Sevantilal Anopchand Shah  
Shree Seating Systems Pvt. Ltd  
Tube Forge Vyapaar Limited  
Versha Ajay Doshi  
Vivek Mundra

2. The shareholding of our Promoters before and after the Issue is as follows:

Name of Promoters	Before the Issue		After the Issue	
	Equity Shares	%	Equity Shares	%
Sungrowth Shares & Stocks Limited	2,14,67,790	33.44	2,14,67,790	23.53%

Mahananda Suppliers Limited	2,41,32,300	37.59	2,41,32,300	26.45%
Jugal Kishore Agarwal	1,101,000	1.71	1,101,000	1.21%
Ghyanshyamdas Agarwal	672888	1.05	672888	0.74%
Nirmal Kumar Agarwal	1,260,500	1.96	1,260,500	1.38%
Mohan Lal Agarwal	11,68,388	1.82	11,68,388	1.28%
Mahesh Kumar Agarwal	9,22,410	1.44	9,22,410	1.01%
Manoj Kumar Agarwal	9,60,366	1.50	9,60,366	1.05%
<b>TOTAL</b>	<b>5,16,85,642</b>	<b>80.51</b>	<b>5,16,85,642</b>	<b>56.65%</b>

### 3. Promoter's Contribution and Lock-in<sup>1</sup>

Details of Promoters contribution locked in for 3 years

Name of the Shareholder	Date of allotment/ when fully paid up	No. of Shares	Consideration	Issue Price / acquisition Price	%age of post- issue paid-up capital	No. of Years for which locked in
MAHANANDA SUPPLIERS LIMITED	31-Mar-04	35000	cash	10	0.04%	1 YEAR
	30-Sep-04	2390000	cash	10	2.62%	3 YEAR
	31-Oct-04	3350000	cash	10	3.67%	3 YEAR
	15-Nov-04	1000000	cash	10	1.10%	3 YEAR
	30-Nov-04	2250000	cash	10	2.47%	3 YEAR
	24-Jan-05	1000000	cash	10	1.10%	3 YEAR
	7-Feb-05	1000000	cash	10	1.10%	3 YEAR
	21-Feb-05	1100000	cash	20	1.21%	3 YEAR
	25-Feb-05	20000	cash	25	0.02%	3 YEAR
	25-Feb-05	180000	cash	25	0.20%	3 YEAR
	16-Mar-05	230800	cash	60	0.25%	3 YEAR
	2-May-05	333000	cash	60	0.37%	3 YEAR
	21-Jul-05	633700	cash	60	0.69%	3 YEAR
	15-Oct-05	300000	cash	60	0.33%	3 YEAR
	Net Transfers	10309800		10	11.30%	1 YEAR
		<b>24132300</b>			<b>26.45%</b>	
NIRMAL KUMAR AGARWAL	31-Mar-04	150000.00	cash	10	0.16%	1 YEAR
	29-Jul-04	50000.00	cash	10	0.05%	1 YEAR
	30-Sep-04	485500.00	cash	10	0.53%	1 YEAR
	7-Feb-05	140000.00	cash	10	0.15%	1 YEAR
	2-May-05	45000.00	cash	60	0.05%	1 YEAR
	27-Aug-05	390000	Non Cash	*	0.43%	1 YEAR
		<b>1260500</b>			<b>1.38%</b>	
SUNGROWTH SHARES & STOCKS LTD.	20-Nov-02	130000.00	cash	100	0.14%	1 YEAR
	31-Jan-03	76500.00	cash	100	0.08%	1 YEAR
	12-Oct-03	4545000.00	cash	10	4.98%	1 YEAR
	4-Feb-04	1100000.00	cash	10	1.21%	1 YEAR

	29-Jul-04	5150000.00	cash	10	5.64%	1 YEAR
	20-Aug-04	3,989,659	cash	10	4.37%	3 YEAR
	20-Aug-04	2,965,341	cash	10	3.25%	1 YEAR
	27-Aug-05	469090	Non Cash	*	0.51%	1 YEAR
	Net Transfers	3042200.00			3.33%	1 YEAR
		<b>21467790</b>			<b>23.53%</b>	
JUGAL KISHORE AGARWAL	Subscriber to the Memorandum	5000.00	cash	10	0.01%	1 YEAR
	6-Oct-03	44,000.00	Bonus	0	0.05%	1 YEAR
	4-Feb-04	155000.00	cash	10	0.17%	1 YEAR
	29-Jul-04	50000.00	cash	10	0.05%	1 YEAR
	30-Sep-04	742000.00	cash	10	0.81%	1 YEAR
	27-Aug-05	105000	Non Cash	*	0.12%	1 YEAR
		<b>1101000</b>			<b>1.21%</b>	
MAHESH KUMAR AGARWAL	Subscriber to the Memorandum	5000.00	cash	10	0.01%	1 YEAR
	6-Oct-03	44,000.00	Bonus	0	0.05%	1 YEAR
	31-Mar-04	5000.00	cash	10	0.01%	1 YEAR
	29-Jul-04	50000.00	cash	10	0.05%	1 YEAR
	30-Sep-04	85000.00	cash	10	0.09%	1 YEAR
	27-Aug-05	52000	Non Cash	*	0.06%	1 YEAR
	Net Transfers	681410			0.75%	1 YEAR
		<b>922410</b>			<b>1.01%</b>	1 YEAR
MOHAN LAL AGARWAL	4-Feb-04	168000.00	cash	10	0.18%	1 YEAR
	29-Jul-04	50000.00	cash	10	0.05%	1 YEAR
	30-Sep-04	619000.00	cash	10	0.68%	1 YEAR
	2-May-05	28000.00	cash	60	0.03%	1 YEAR
	27-Aug-05	15000	Non Cash	*	0.02%	1 YEAR
	27-Aug-05	150000	Non Cash	*	0.16%	1 YEAR
	Net Transfers	138388.00			0.15%	1 YEAR
		<b>1168388</b>			<b>1.28%</b>	1 YEAR
MANOJ KUMAR AGARWAL		5000.00	cash	10	0.01%	1 YEAR
		44,000.00	Bonus	0	0.05%	1 YEAR
	4-Feb-04	7720.00	cash	10	0.01%	1 YEAR
	2-May-05	50000.00	cash	60	0.05%	1 YEAR
	27-Aug-05	112810	Non Cash	*	0.12%	1 YEAR
	Subscriber to the Memorandum	5000.00	cash	10	0.01%	1 YEAR
	6-Oct-03	44,000.00	Bonus	0	0.05%	1 YEAR
	4-Feb-04	25000.00	cash	10	0.03%	1 YEAR

	29-Jul-04	50000.00	cash	10	0.05%	1 YEAR
	30-Sep-04	75000.00	cash	10	0.08%	1 YEAR
	27-Aug-05	115000	Non Cash	*	0.13%	1 YEAR
	Net Transfers	426836			0.47%	1 YEAR
<b>Total</b>		<b>960366</b>			<b>1.05%</b>	

\* Shares issued pursuant to amalgamation of our Company with Adhunik Minerals and Alloys Limited.

<sup>1</sup> Promoters contribution shall be finalized upon finalization of the price of the Equity Shares.

Out of the total shareholding of the promoters 182,46,249 number of equity shares held by Sungrowth Shares & Stocks Limited and Mahananda Suppliers Limited being 20% of the post issue capital will be locked in for a period of three years.

Lock-in period shall start from the date of allotment of the Equity Shares in terms of the Prospectus.

In terms of Clause 4.14.1 of the SEBI Guidelines, in addition to the lock-in of 20% of post Issue shareholding of the Promoters for three years, as specified above, the entire pre-Issue share capital (excluding the Promoter's Contribution) shall be locked-in for a period of one year from the date of allotment in this Issue.

The locked in Equity Shares held by the Promoter, as specified above, can be pledged only with banks or financial institutions as collateral security for loans granted by such banks or financial institutions provided that the pledge of shares is one of the terms of sanction of loan.

In terms of Clause 4.16.1(b) of the SEBI Guidelines, the Equity Shares held by the Promoter may be transferred to and amongst the Promoter Group or to new promoters or persons in control of the Company subject to continuation of the lock-in in the hands of the transferees for the remaining period and compliance with SEBI (Substantial Acquisition of Shares and Takeovers) Regulations, 1997, as applicable.

In terms of Clause 4.16.1 (a) of the SEBI Guidelines, the Equity Shares held by persons other than Promoters, prior to the Issue may be transferred to any other person holding the Equity Shares which are locked-in as per Clause 4.14 of the SEBI Guidelines, subject to continuation of the lock-in in the hands of the transferees for the remaining period and compliance with SEBI (Substantial Acquisition of Shares and Takeovers) Regulations, 1997, as applicable.

In addition, the Equity Shares subject to lock-in will be transferable subject to compliance with SEBI Guidelines, as amended from time to time.

#### 4. Shareholding Pattern of our Company

The table below presents our shareholding pattern before the proposed Issue and after the Issue:

Particulars	Pre Issue		Post Issue	
	Number of Equity Shares	Percentage of Equity Share Capital	Number of Equity Shares	Percentage of Equity Share Capital
<b>Promoters</b>				
Sungrowth Shares & Stocks Limited	2,14,67,790	33.44	2,14,67,790	23.53%
Mahananda Suppliers Limited	2,41,32,300	37.59	2,41,32,300	26.45%
Jugal Kishore Agarwal	1,101,000	1.71	1,101,000	1.21%
Ghyansham Das Agarwal	672888	1.05	672888	0.74%
Nirmal Kumar Agarwal	1,260,500	1.96	1,260,500	1.38%
Mohan Lal Agarwal	11,68,388	1.82	11,68,388	1.28%
Mahesh Kumar Agarwal	9,22,410	1.44	9,22,410	1.01%
Manoj Kumar Agarwal	9,60,366	1.50	9,60,366	1.05%
<b>SUB TOTAL ( A )</b>	<b>5,16,85,642</b>	<b>80.50</b>	<b>5,16,85,642</b>	<b>56.65%</b>
<b>PROMOTER GROUP</b>				
Adhunik Corporation Limited*	Nil	Nil	Nil	Nil
Adhunik Alloys & Power Limited*	Nil	Nil	Nil	Nil
Adhunik Steels Limited*	7,58,492	1.18	7,58,492	0.83%
Neepaz Tube (P) Limited*	35,000	0.05	35,000	0.04%
Adhunik Meghalaya Steels Private Limited*	16,00,000	2.49	16,00,000	1.75%
Adhunik Infotech Limited*	Nil	Nil	Nil	Nil
Adhunik Ispat Limited*	40,000	0.06	40,000	0.04%
Adhunik Thermal Energy Limited.*	Nil	Nil	Nil	Nil
Adhunik Metcoke Pvt. Limited.*	Nil	Nil	Nil	Nil
Manohar Management Limited*	2,030,000	3.16	2,030,000	2.23%
Futuristic Steel Private Limited *	Nil	Nil	Nil	Nil
Sri. M. P. Ispat Private Limited *	Nil	Nil	Nil	Nil
Swarnrekha Steel Industries; *	Nil	Nil	Nil	Nil
Shivalik Transport*	Nil	Nil	Nil	Nil

Particulars	Pre Issue		Post Issue	
	Number of Equity Shares	Percentage of Equity Share Capital	Number of Equity Shares	Percentage of Equity Share Capital
Sachin Kumar Agarwal	Nil	Nil	Nil	Nil
Meena Agarwal	6,90,000	1.07	6,90,000	0.76%
Ekta Agarwal	1,90,000	0.30	1,90,000	0.21%
Chandrakanta Agarwal	5,15,000	0.80	5,15,000	0.56%
Anita Agarwal	1,33,388	0.21	1,33,388	0.15%
Sonika Agarwal	3,90,000	0.61	3,90,000	0.43%
Permila Agarwal	36,090	0.06	36,090	0.04%
Rita Agarwal	225,000	0.35	225,000	0.25%
Naveen Agarwal	Nil	Nil	Nil	Nil
Smita Agarwal	70,800	0.11	70,800	0.08%
<b>SUB TOTAL (B)</b>	<b>67,13,770</b>	<b>10.46</b>	<b>67,13,770</b>	<b>7.36%</b>
<b>TOTAL PROMOTER HOLDING ( C = A+B)</b>	<b>5,83,99,412</b>	<b>90.96</b>	<b>5,83,99,412</b>	<b>64.01%</b>
<b>Non Promoters</b>				
Others	58,04,808	9.04	32,831,835	35.99%
<b>SUB TOTAL (D)</b>	<b>58,04,808</b>	<b>9.04</b>	<b>32,831,835</b>	<b>35.99%</b>
<b>TOTAL (C+D)</b>	<b>6,42,04,220</b>	<b>100.00</b>	<b>91,231,247</b>	<b>100.00%</b>

\* The Natural persons in control of the corporate bodies included in the promoter Group are:

Mr. Jugal Kishore Agarwal  
Mr. Ghanshyamdas Agarwal  
Mr. Nirmal Kumar Agarwal  
Mr. Mohan Lal Agarwal  
Mr. Mahesh Kumar Agarwal  
Mr. Manoj Kumar Agarwal

None of the persons/entities included in the promoter and promoter group have been debarred from accessing the capital market by SEBI and no action has been taken by SEBI or any other regulatory body against them.

5. Our Promoters have on December 31, 2005, purchased 1,12,89,652 Equity Shares at a price of Rs.10 per Equity Share. The details of the same are as follows:

NAME OF PROMOTER	NAME OF SELLER	NUMBER OF EQUITY SHARES
Manoj Kumar Agarwal	Sachin Kumar Agarwal	273612
Manoj Kumar Agarwal	Ekta Agarwal	390000
Manoj Kumar Agarwal	Smita Agarwal	77224
Mahesh Kumar Agarwal	Naveen Kumar Agarwal	45022
Mahesh Kumar Agarwal	Sachin Kumar Agarwal	636388
Mohan Lal Agarwal	Anita Agarwal	91612
Mohan Lal Agarwal	Smita Agarwal	46776
Ghanshyamdas Agarwal	Naveen Kumar Agarwal	154978
Ghanshyamdas Agarwal	Permila Agarwal	203910
Adhunik Ispat Limited	Sitaram Sharaff	25000
Adhunik Ispat Limited	Guddu Sharaff	10000
Adhunik Ispat Limited	Annapurna Sharaff	5000
Mahananda Suppliers Limited	Dolphin Infotech Limited	1950000
Mahananda Suppliers Limited	Stephen Marketing Ltd.	2243700
Mahananda Suppliers Limited	Information Synergies Pvt. Ltd.	1330000
Mahananda Suppliers Limited	JB Tea Trading (P) Ltd.	352800
Mahananda Suppliers Limited	Rovam Tieup Pvt. Ltd.	150300
Mahananda Suppliers Limited	Rovam Tieup Pvt. Ltd.	450300
Mahananda Suppliers Limited	Shri Vaikuntnath Trading (P) Ltd.	379300
Mahananda Suppliers Limited	Shresth Consultancy Private Limited.	500000
Mahananda Suppliers Limited	Shrinagar Marketing (P) Ltd.	280000
Mahananda Suppliers Limited	Vijay Enclave Ltd.	419200
Mahananda Suppliers Limited	Vijay Greenfields	940500
Mahananda Suppliers Limited	Devasya Distributors Pvt. Ltd.	324000
Mahananda Suppliers Limited	Vibhore Trading & Finance Ltd.	10030

Except as mentioned above, none of the persons listed in our Promoter or Promoter Group, or the directors of our Promoter Group companies or our Directors have purchased or sold any Equity Shares in the last six months preceding the filing of this Prospectus.

6. The list of the top ten shareholders of our Company and the number of Equity Shares held by them is as under:
- (a) The top shareholders of our Company as of the date of filing the Prospectus with SEBI/RoC are as follows:

Sr. No.	Name of Shareholders	Number of Equity Shares	% of paid up capital
1.	Mahananda Suppliers Limited	2,41,32,300	37.59
2.	Sungrowth Shares & Stocks Limited	2,14,67,790	33.44
3.	Manohar Management Limited	2,030,000	3.16
4.	Hexagram Investment Pvt. Ltd.	19,00,000	2.96
6.	Adhunik Meghalaya Steels Private Limited	1,600,000	2.49

7.	Murli Management Limited	1,568,100	2.44
8.	Nirmal Kumar Agarwal	1,260,500	1.96
9.	Mohan Lal Agarwal	11,68,388	1.82
10.	Jugal Kishore Agarwal	1,101,000	1.71

(b) The top shareholders of our Company ten days prior to filing the Prospectus with SEBI/RoC are as follows:

Sr. No.	Name of Shareholders	Number of Equity Shares	% of paid up capital
1.	Mahananda Suppliers Limited	2,41,32,300	37.59
2.	Sungrowth Shares & Stocks Limited	2,14,67,790	33.44
3.	Manohar Management Limited	2,030,000	3.16
4.	Hexaram Investment Pvt. Ltd.	19,00,000	2.96
6.	Adhunik Meghalaya Steels Private Limited	1,600,000	2.49
7.	Murli Management Limited	1,568,100	2.44
8.	Nirmal Kumar Agarwal	1,260,500	1.96
9.	Mohan Lal Agarwal	11,68,388	1.82
10.	Jugal Kishore Agarwal	1,101,000	1.71

(c) The top shareholders of our Company two years prior to filing the Prospectus with SEBI/RoC are as follows:

Sr. No.	Name of Shareholders	Number of Equity Shares	% of paid up capital
1.	Sungrowth Shares & Stocks Limited	2,09,98,700	54.04
2.	Mahananda Suppliers Ltd.	24,25,000	6.24
3.	Stephen Marketing Ltd.	2,062,900	5.31
4.	Manohar Management Limited	12,87,000	3.31
5.	Jugal Kishore Agarwal	9,96,000	2.56
6.	Vijay Greenfileds Limited	9,10,500	2.34
7.	Mohan Lal Agarwal	8,37,000	2.15
8.	Nirmal Kumar Agarwal	6,85,500	1.76
9.	Information Synergies Pvt. Ltd.	6,20,000	1.60
10.	Heaven Barter Limited	4,90,000	1.29

7. There are no outstanding warrants, options or rights to convert debentures, loans or other instruments into our Equity Shares.

8. We have not granted any options or issued any shares under any employee stock option or employee stock purchase scheme.
9. A Bidder cannot make a Bid for more than the number of Equity Shares offered through the Issue. A Bidder can bid for more no. of shares than available for the investor category subject to the maximum limit of investment prescribed under relevant laws applicable to each category of investor.
10. Our Company, our Directors and the BRLM have not entered into any buy-back and/ or standby arrangements for purchase of Equity Shares from any person.
11. In case of over-subscription in all categories, at least 50% of the Net Issue shall be available for allocation on a proportionate basis to QIB Bidders. 5% of the QIB Portion shall be available to Mutual Funds. Mutual Funds participating in the 5% share in the QIB Portion will also be eligible for allocation in the remaining QIB Portion. If at least 50% of the Net Issue cannot be allotted to QIBs, then the entire application money will be refunded. Further, upto 15% of the Net Issue shall be available for allocation on a proportionate basis to Non-Institutional Bidders and upto 35% of the Net Issue shall be available for allocation on a proportionate basis to Retail Individual Bidders, subject to valid Bids being received at or above the Issue Price. Under-subscription, if any, in the Non-Institutional Portion and Retail Portion would be met with spill-over from other categories, at our sole discretion, in consultation with the BRLM and the Designated Stock Exchange.
12. Only Employees would be eligible to apply in this Issue under the Employee Reservation Portion on competitive basis. Employees other than as mentioned in this Prospectus are not eligible to participate under the Employee Reservation Portion. Employees have the option to bid in the “Net Issue” to the public portion. If the aggregate demand in the Employee Reservation Portion is greater than 13,51,351 Equity Shares at or above the Issue Price, allocation shall be made on a proportionate basis. The unsubscribed portion, if any, from the Equity Shares in the Employee Reservation Portion will be treated as part of the Net Issue and the proportionate allocation of the same would be at the sole discretion of the Company in consultation with the BRLM and the Designated Stock Exchange.
13. Except as disclosed in this Prospectus, none of our Directors and key managerial employees hold any Equity Shares.
14. We undertake that there would be no further issue of capital whether by way of issue of bonus shares, preferential allotment, rights issue or in any other manner during the period commencing from submission of this Prospectus with SEBI until the Equity Shares to be issued pursuant to the Issue have been listed. We may issue non convertible debentures to meet our funding requirements during such period.
15. We presently do not intend or propose to alter our capital structure for a period of six months from the Bid/ Issue Opening Date, by way of split or consolidation of the denomination of Equity Shares or further issue of Equity Shares (including issue of securities convertible into or exchangeable, directly or indirectly for Equity Shares), whether preferential or otherwise, except if we enter into acquisitions or joint ventures, we may, subject to necessary approvals, consider raising additional capital to fund such activity or use Equity Shares as currency for acquisition or participation in such joint ventures.
16. We undertake not to alter our capital structure as provided above during the period from the date of filing of the Draft Prospectus with SEBI and the date of allotment of equity shares pursuant to this Issue.
17. There shall be only one denomination of the Equity Shares, unless otherwise permitted by law. We shall comply with such disclosure and accounting norms as may be specified by SEBI from time to time.

18. As on the date of filing of the PROSPECTUS with SEBI/RoC, the total number of holders of Equity Shares are 50.
19. We have not raised any bridge loans against the proceeds of the Issue.
20. We have not issued any Equity Shares out of revaluation reserves. Except as mentioned under the chapter on Capital Structure we have not issued any Equity Shares for consideration other than cash.
21. An over subscription to the extent of 10% of the Issue can be retained for the purposes of rounding of to the nearest multiple while finalizing the Basis of Allotment.

## OBJECTS OF THE ISSUE

The objects of the Issue are to: -

- To expand and forward integrate the operations of the Company by setting up the following units, collectively referred to as Unit III:-
  - a) 2<sup>nd</sup> SMS with Vacuum Degassing (VD) Plant
  - b) Rolling Mill
  - c) Argon Oxygen Degassing Plant with Bloom CCM
  - d) Ferro Alloy Division
  - e) 2<sup>nd</sup> Captive Power Plant
  - f) Sinter Plant
  - g) Oxygen Plant
  - h) Private Railway Siding
  - i) Captive Iron Ore & Coal Mining and
  
- To get the Equity Shares of the Company listed on the BSE and the NSE.

The main objects clause and objects incidental or ancillary to the main objects clause of the Memorandum of Association of the Company enable the Company to undertake the existing activities and the activities for which the funds are being raised through the present Issue. AML further confirms that the activities of the Company carried out till date are in accordance with the objects of the Memorandum of Association of the Company.

### Cost of the Project

The total cost of the project (Unit III) is estimated at Rs. 43,736 Lacs. The financial appraisal of the project has been done by SBI Capital Markets Limited based on the estimates provided by technical consultants, for various plant and machinery items as also suitable contingency provisions provided on these costs. The project is technically appraised by United Consultants ( India) Pvt. Ltd.

The different heads of project cost are detailed in the table given below:

Particulars	Rs. In Lacs
Land & Site Development	2,317
Civil & Structural Works	6,402
Plant & Machinery	19,010
Electrical Installations	6,372
Miscellaneous Fixed Assets	2,675
Security Deposit	200
Preliminary Expenses	20
Pre-operative Expenses (incl. Issue Expense)	1,030
Technical Know-how Fees	334
Contingency *	1,830
Margin Money for Working Capital	2,150
Interest During Construction (IDC)	1,396
<b>Total</b>	<b>43,736</b>

*\* considered at 5% on non-firm costs*

### **Scope of the Financial Appraisal carried out by SBI Capital Markets**

The scope and purpose of the Appraisal carried out by SBI Capital Markets Limited was to assess the financial viability of the project as envisaged by the Company. The appraising agency has vide its Financial Appraisal Note (“ FAN”) dated September, 2005 stated that subject to the weaknesses and threats set out in the FAN and the impact of the various scenarios as envisaged under the sensitivity analysis study, the capital expenditure is viewed as financially viable.

### **Scope of the Technical Appraisal carried out by United Consultants India Pvt. Ltd.**

The scope and purpose of the technical appraisal conducted by United Consultants India Pvt. Ltd. during September 2005 was to provide the technical knowhow and the costs involved in implementing the expansion project and included the following:

Preparation of Bankable techno-economic feasibility report for the project and Co-ordination with all technical / financial consultants for the purpose of Technical Economic Feasibility Report (‘TEFR’) preparation and providing all technical inputs and production / capital cost estimates with respect to the various modules of the project.

**A detailed breakup of the costs involved are provided in the following paragraphs:**

#### **Land & Site Development**

The description and schedule of costs for land and site development is provided below:-

Amounts in Rs. Lacs

Sl. No.	Description	Amount
<b>(A)</b>	<b>LAND</b>	
i)	Freehold Land measuring 4.08 Acres i.e. approximately at Vill-Chadri Hariharpur, Block-Kuarmunda, District-Sundargarh, Orissa.	1.76
	<b>Total (A):</b>	<b>1.76</b>
<b>(B)</b>	<b>SITE DEVELOPMENT EXPENSES</b>	
i)	Leveling and Development of Land	100.00
ii)	Borewells	30.00
iii)	<b>Roads</b>	
	7 M Wide Road ( 2800 M @ Rs. 400/Sq. M)	11.00
	4 M Wide Road ( 2500 M @ Rs. 400/Sq. M)	10.00
	30 M Wide Road (750 M @ Rs. 400/Sq. M)	3.00
iv)	<b>Cost of Compound Wall -</b>	
	2900 M @Rs. 2800 RM	81.00
v)	Drainage (1500 M @ Rs. 1500/RM)	23.00
vi)	Gate (1 No.)	5.00
	<b>Total (B):</b>	<b>263.00</b>
<b>(C)</b>	<b>IRON ORE MINES</b>	
<b>a)</b>	<b>Kulum Mines</b>	
i)	Approach Roads (2 Kms @ Rs. 3.5 lac)	7.00
ii)	Culverts	1.00
iii)	Others	2.00
iv)	Mining Plan, Survey & Execution Expenses and Envoinmental Clearance Expenses	16.00
v)	Site Levelling and Forest Diversion Expenses (5 hectares @ Rs. 10.00 lac)	50.00
vi)	Mining Dvelopment Expenses (Removal of 12000 cum of Overburden from 3 Quarries @ Rs. 80.00 per cum)	28.80
<b>b)</b>	<b>Khajuridihi Mines</b>	
i)	Approach Roads (12 Kms @ Rs. 3.5 lac)	42.00
ii)	Culverts	3.00
iii)	Others	4.00
iv)	Mining Plan, Survey & Execution Expenses and Envoinmental Clearance Expenses	20.00
v)	Site Levelling and Forest Diversion Expenses (28 hectares @ Rs. 10.00 lac)	280.00
vi)	Mining Dvelopment Expenses (Removal of 27000 cum of Overburden from 3 Quarries @ Rs. 80.00 per cum)	64.80
	<b>Total (C):</b>	<b>518.60</b>
<b>(D)</b>	<b>COAL MINES</b>	
	<b>Patrapara Coal Block</b>	
i)	Land Acquisition and Rehabilitation	302.00
ii)	Envoinmental Clearance, Mining Plan, Survey & Execution Expenses	150.00
iii)	Mines Development & Over Burden removal, Road & Other Mining Infrastruture	1082.00
	<b>Total (D):</b>	<b>1534.00</b>
	<b>Total (A+B+C+D):</b>	<b>2317.36</b>

The land admeasuring 17.02 acres has been acquired for the expansion. Out of this, 4.08 acres of land is purchased in the name of AML while the remaining land is purchased in the name of Smt. Chandrakanta Agarwal and Smt. Sonika Agarwal who are related to the promoters. The land purchased in the name of Smt. Chandrakanta Agarwal and Smt. Sonika Agarwal is leased to AML. The cost of purchased land is Rs. 0.02 crores.

Site development cost is estimated at Rs. 2.63 crores.

Mining development cost is based on the estimate provided by Geomin Project Consultants, who have prepared the project report for the proposed captive coal and iron ore mines.

For further details on the land, proposed iron ore mines and the coal mine please refer to section on “ History of Our Company and Other Corporate Matters” on page no. 104 of this Prospectus.

### **Civil & Structural Work**

The estimated cost of civil and structural works for the proposed Unit has been worked out on the basis of proposed layout and facilities required and rates for civil and structural works as applicable in the area. The facilities included in the estimates are civil and structural works for main plant and equipment and for miscellaneous fixed assets, as well as for factory and non-factory buildings.

A description of the proposed civil & structural work and the schedule of costs is provided below:-

<b>Sl. No.</b>	<b>Item Description</b>	<b>in Rs. Lacs</b>
I.	General	421
II.	Ferro Alloys Division	955
III.	Steel Melting Shop - II (With VD)	1,621
IV.	AOD & Concast Division	252
V.	Captive Power Plant	794
VI.	Oxygen Plant	189
VII.	Private Railway Siding	575
VIII.	Rolling Mill Division	1,220
IX.	Sinter Plant	100
X.	Iron Ore Mines	173
XI.	Coal Mines	102
	Total :	<b>6,402</b>

### **Plant & Machinery**

The principal items of plant & machinery for the project would include hydraulic systems, electrode cooling systems, fabricated equipment for furnace, refractory items, raw material handling items, conveyor system and mechanical items, complete briquetting plant, finished metal handling system, Electric Arc Furnace (EAF) with EBT accessories, 35T Ladle Furnace and EAF Transformer and accessories. The total cost of the plant & machinery proposed to be procured for the project is Rs. 190 crores, the break-up of which is provided below:-

Sl.	Particulars	Name of prospective supplier	Rs. In Lacs
<b>I.</b>	<b>FERRO ALLOYS DIVISION</b>		
<b>1</b>	<b>Copper Items (Basic Price In Rs.)</b>	METSA Engineering Co.	146.97
<b>2</b>	<b>Electrode Cooling</b>	Ria enterprises	6.27
<b>3</b>	<b>Hydraulic System</b>	Vickers Systems International Ltd./Gartels Werle Ltd.	29.39
<b>4</b>	<b>Pneumatic System</b>	Veljan Hydrair Pvt.Ltd./Gartel Werke Ltd.	57.36
<b>5</b>	<b>Refractory</b>	SKG Refractories Ltd./Grindwell Norton/INDAL/Hyderabad Traders	139.71
<b>6</b>	<b>Furnace - Steel fabricated Equipment</b>	<b>RgCon Services</b>	190.20
<b>7</b>	<b>Stainless Steel Items</b>	NIL	127.50
<b>9</b>	<b>Raw Material Handling</b>	Multiweigh Systems/NRC Industries/Elecon Engg./Electromag Devices/Static Power System/Internation Combustion	60.35
<b>10</b>	<b>Conveyor Mechanicals</b>	DevCon Systems	48.74
<b>11</b>	<b>Briquetting Plant Complete</b>	Ushakiran Industries	308.48
<b>12</b>	<b>Bag Filter House Complete</b>	R D Pollution Controls Pvt. Ltd.	260.71
<b>13</b>	<b>Finished Metal Handling System</b>	Ushakiran Industries/Federal Engg	77.17
14	Stores & Spares @ 2%		25.00
15	Freight & Insurance @ 3%		38.00
16	Equipment Erection @ 5%		64.00
	<b>Sub Total (I):</b>		<b>1579.85</b>

<b>II</b>	<b>SMS - II (WITH VD)</b>		
1	EOT Cranes	Furnace & Foundary Equipment Co./Prowess/WMI/Robin/Fafeco	153.01
2	35T Electric Arc Furnace AF ,LF including DRI Charging and handling System	Prowess International Engg. & Consult./CGL/ Alstom/Voltamp/Paradigm /Fobes Marshall /ADS Corp	1341.26
3	Other Equipments	Concast India Ltd. / Prowess International/ Ajay Enterprises/Surface Finishing Equipment Co./Softron Control Systems	462.04
4	Refractories	OCL India Limited / IFGL Refractories Ltd/Visuvious/Servesh Refractories/Steelo Equipment/Metropolitan Equipments & Consultants/Prowess International/Rieco Engnn./NICO/Batliboi/Thermax	308.50
6	Fume Extraction System	Batliboi Environmental Engn. Ltd./Shree NM Energy Management Centre/Devcon Systems & Projects Pvt. Ltd.etc.	731.73
7	Equipments for Vaccum Degasing	Prowess International, Jamshedpur/OCL/Sarvesh/Steelo Equipment	799.58
8	Stores & Spares @ 2%		62.00
9	Freight & Insurance @ 3%		92.00
10	Equipment Erection @ 5%		154.00
	<b>Sub Total (II):</b>		<b>4104.12</b>

<b>III.</b>	<b>AOD &amp; CONCAST DIVISION</b>	United Engg & Metallurgicals/K.N.Thermal	324.52
<b>3</b>	<b>Fume Extraction System</b>	Shree NM Energy Management Centre/ Batloboi Environmental Engr. Ltd./Steelo Equipments /Metropolition/PI	317.12
<b>5</b>	<b>Auxiliaries Equipments</b>	Steelo/Electronite/Watertech/Wheel board/Vikash Iron	139.69
<b>7</b>	<b>Bloom Concast</b>	Concast	1265.40
<b>8</b>	<b>Cranes</b>	Furnace & Foundary	265.30
<b>9</b>	<b>Water System</b>	Paltech Cooling Towers	43.18
10	Stores & Spares @ 2%		38.00
11	Freight & Insurance @ 3%		57.00
12	Equipment Erection @ 5%		95.00
	<b>Sub Total (III):</b>		<b>2545.21</b>
<b>IV.</b>	<b>ROLLING MILL</b>		
<b>1</b>	<b>Reheating Furnace Equipment</b>	Based on the Budgetary Estimates from Korus Engineering Solutions Pvt. Ltd.	1285.76
<b>2</b>	<b>700 mm 2 Hi reversing Mill</b>	NIL	1546.13
<b>3</b>	<b>600 mm Intermeidate Mill &amp; Finishing Mill</b>	Nil	715.70
<b>3</b>	<b>Hot Saws</b>	Nil	151.78
<b>3</b>	<b>Cooling Bed</b>	Nil	412.13
<b>3</b>	<b>E O T Cranes</b>	Nil	308.48
<b>4</b>	<b>Rolls &amp; Guide</b>	Nil	246.79
			<b>4666.77</b>
6	Stores & Spares @ 2%		76.00
7	Freight & Insurance @ 3%		113.00
8	Equipment Erection @ 5%		189.00
	<b>Sub Total (IV):</b>		<b>5044.77</b>

<b>V.</b>	<b>SINTER PLANT</b>	<b>Under EPC of Ferro Technologies</b>	<b>413.39</b>
22	Stores & Spares @ 2%		7.00
23	Freight & Insurance @ 3%		10.00
24	Equipment Erection @ 5%		17.00
	<b>Sub Total (V):</b>		<b>447.39</b>
<b>VI.</b>	<b>CAPTIVE POWER PLANT 18 MW</b>	Thermax Babcock & Wilcox Ltd./Cethar Vessels Pvt. Ltd./Ingersoll Rand	<b>4229.67</b>
10	Stores & Spares @ 2%		69.00
11	Freight & Insurance @ 3%		103.00
12	Equipment Erection @ 5%		171.00
	<b>Sub Total (VI):</b>		<b>4572.67</b>
<b>VII.</b>	<b>OXYGEN PLANT</b>		
1	Equipment for Air Generation	Sanghi Oxygen	481.24
2	Other Equipment	India Compressor/Raj Engineering/Voltas/Paharpur Cooling Towers	179.55
3	Stores & Spares @ 2%		11.00
4	Freight & Insurance @ 3%		16.00
5	Equipment Erection @ 5%		27.00
	<b>Sub Total (VII):</b>		<b>714.79</b>
	<b>Total (I+II+III+IV+V+VI+VII+VIII):</b>		<b>19008.80</b>

The Company has placed orders for turbine for its upcoming power plant, Oxygen plant. The Company has appointed Avant Garde, Chennai as its consultant for upcoming power plant, and Corus Engineering, Delhi as its consultant for detail engineering and master planning for its upcoming Rolling Mill, Steel Melting Shop, Argon Oxygen Decarburization, Vacuum Degassing. Further AML is in the process of finalizing the vendor for its upcoming expansion. The Company has identified the vendors for supply of equipments and floated enquiries to various vendors.

The proposed project requires various machineries and equipments which are easily available in India and Company is planning to source them indigenously, hence there are no plans presently to import major machinery / equipment.

### Electrical Installations

The total cost envisaged for electrical installations for the project is Rs. 6,372 lacs. A break-up of the cost is provided below:-

<b>Particulars</b>	<b>in Rs. Lacs</b>
Ferro Alloys Division	1,295
SMS - II With V D	1,887
AOD & Concast	273
Rolling Mill	601
Sinter Plant	101
CPP	1,745
Oxygen Plant	240
Railway Siding	146
Iron Ore Mines	42

Coal Mines	42
<b>Total</b>	<b>6,372</b>

#### Miscellaneous Fixed Assets

The total cost for miscellaneous fixed assets has been estimated at Rs. 2,675 lacs. A break-up of the cost schedule for miscellaneous fixed assets is provided below:-

<b>Particulars</b>	<b>in Rs. Lacs</b>
Ferro Alloys Division	220
SMS - II With V D	454
Rolling Mill	847
CPP	139
Railway Siding	429
Iron Ore Mines	86
Coal Mines	82
Common	418
<b>Total</b>	<b>2,675</b>

#### Security Deposit

The total security deposit as per the agreement with Western Electricity Supply Company of Orissa Ltd. (WESCO) is Rs. 700 Lacs. Out of it, Rs. 500 Lacs has been considered as a part of Unit II project cost and hence the remaining part of Rs. 200 Lacs has been considered in this project.

#### Preliminary Expenses

The preliminary expenses of Rs. 20 Lacs have been considered, which include fees payable to the Registrar of Companies to increase the authorized share capital.

#### Preoperative Expenses

The preoperative expenses for the project are estimated at Rs. 1,030 Lacs which includes upfront fees at 0.25% charged by lenders and IPO related expenses at 8% of the issue size of approximately Rs. 10,000 Lacs. The detailed breakup of the preoperative expenses is as follows.

*(Rs. in Lacs)*

<b>Particulars</b>	<b>Total</b>
Establishment Expenses	50.00
IPO Related Expenses	800.00
Consultancy Fees, Project Appraisal and Debt Syndication Fees	100.00
Up-front Fees	80.00
<b>Total :</b>	<b>1030.00</b>

#### Technical Know-how Fees

Technical know-how fees of Rs. 334 Lacs is estimated based on the technical agreements entered / proposed to be entered into by us.

### Contingency

Provision for contingency has been considered at 5% on the basis of all non-firm hard cost components, which amounts to Rs. 1830 Lacs.

### Margin Money for Working Capital

The working capital margin requirement of the project is estimated at Rs. 2150 Lacs, based on the calculations for the first full year of operations (excluding captive mining operations, which start in the year 2008-09) for the project i.e. 2007-08. The particulars for the same are as given below.

Particulars	Stocking period in days/percentage (as applicable)	2007-08 (Rs. In Lacs)
<u>Raw Materials</u>		
Imported	90	2,561
Indigenous	30	3,599
Consumables	30	618
Work-in-Progress	3	644
Finished Goods (Incl. By Products)	15	3,325
Receivables	30	9,026
Expenses for one month	30	144
Working Capital requirement		19,917
Less : Sundry Creditors		
Indigenous	10	1,263
Imported	60	1,741
<b>Working Capital Gap</b>		<b>16,913</b>
<u>Margin Money against:</u>		
Raw Materials - Indigenous	25%	900
Raw Materials - Imported	25%	640
Consumables	25%	155
Work-in-Progress	25%	161
Finished Goods (Incdg. By Products)	25%	831
Receivables	25%	2,256
Expenses for one month	100%	144
<b>Total Margin</b>		<b>5,088</b>
Margin already brought in during previous projects		2,938
<b>Margin required for the project</b>		<b>2,150</b>

### Present Working Capital Facilities

The Company presently enjoys Fund Based working capital limits to the extent of Rs. 5670 Lacs and Non Fund Based Working Capital Limited to the extent of Rs. 3,600 Lacs as on September 30, 2005 from State Bank of India, Indian Overseas Bank and State Bank of Mysore.

### Interest During Construction

The project would start its operations in three distinct phases viz.

Phase A: which ends on 31<sup>st</sup> March, 2007 and at the end of this phase the operations of Ferro alloy division, SMS II with VD, AOD and Concast, Rolling Mill, Sinter Plant, Oxygen Plant and railway siding would start.

Phase B: which ends on 30<sup>th</sup> June, 2007 and at the end of this phase the operation of the captive power plant of 18 MW would start.

Phase C: which ends on 31<sup>st</sup> March, 2008 and at the end of this phase operation of captive iron ore and coal mines would begin.

Relevant interest up to the commencement of commercial production under the above mentioned phases has been considered as Interest During Construction on proportionate basis. The interest rate for the same has been assumed as 8.5% p.a.

### **Means of Finance**

The project is proposed to be funded by term loans from banks, financial institutions and equity. The proposed means of the finance for the project will be as under:

Means of Finance	Total (Rs. in Lacs)
Equity Capital:	
Issue	10000
Internal Accruals	5307
Debt:	
Term Loans	28429
<b>Total</b>	<b>43736</b>

### **Internal Accruals**

The project is proposed to be part funded through internal accruals amounting to Rs. 5307 Lacs. The Company has Free Reserves to the extent of Rs. 1,932.60 Lacs as on September 30, 2005. The Company has already deployed funds to the extent of Rs. 1212.26 Lacs out of internal accruals towards the expansion project as per the certificate dated February 25, 2006 issued by ABR & Co., Chartered Accountants.

The balance amount Rs. 1,081 Lacs out of internal accruals is proposed to be spent upto March, 2008. The Company has reported a Profit After Tax of Rs. 1,681.28 Lacs on a Total Income of Rs. 24,045.19 Lacs for the nine months period ended on December 31, 2005 as per the audited accounts. Thus the Company has adequate internal accruals to part finance the expansion as per the Means of Finance stated above.

### **Debt**

The entire debt component of Rs. 284.29 crore is being funded by Rupee Term Loan. The Company has received the sanction from banks for the entire debt component.

The broad terms of the proposed term loan is as given below:

Nature of borrowing	Rupee Term Loan
Loan Amount	Rs. 28,429 lakhs
Interest Rate	8.50% p.a.

Moratorium Period	15 months from CoD (completion of Phase A)#
Repayment	24 Quarterly installments commencing after 15 months of Moratorium.
Security	<ol style="list-style-type: none"> <li>1. First pari-passu charge on all fixed assets of the company.</li> <li>2. Second pari-passu charge on all current assets of the company.</li> <li>3. Equitable mortgage on the land and building of the company.</li> <li>4. Personal Guarantee of the promoters. Total net means as on 31<sup>st</sup> March 2005 is Rs. 2,506 lakhs.</li> </ol>

# On 31<sup>st</sup> March, 2007 the operations of Ferro alloy division, SMS II with VD, AOD and Concast, Rolling Mill, Sinter Plant, Oxygen Plant and railway siding would start. Thus the moratorium shall start from 1<sup>st</sup> April 07.

The Company has received final sanction of Rs. 39,000 Lacs as on February 27, 2006, for its proposed expansion as against its total requirement of Rs. 28,429 Lacs. The details of which is as under:

Letter No.	Date	Name of the Bank	Sanctioned Amt ( Rs. In Lacs)
Nil	December 30, 2005	Punjab National Bank	7500.00
IOB/IEP/015	20/12/2005	Indian Overseas Bank	5000.00
KMO/CAD/2005-06/02/795	February 17, 2006	Central Bank of India	4500.00
IFB:KOL:793:05	16-01-06	Union Bank of India	3500.00
AGM/ADV/2005-06	06.01.2006	UCO Bank	3000.00
KMO/ADV/70/086	1 <sup>st</sup> Feb. 2006	Bank of Baroda	3000.00
CMK/9591/ADV/722/05	31/12/2005	Syndicate Bank	2500.00
DGM/CHE/SNS/AML	30.12.2005	State Bank of Travancore	2500.00
aml/229	24/01/2006	State Bank of Mysore	2000.00
-	17/01/2006	Oriental Bank of Commerce	2000.00
DB1:ADV:BNC	20.12.2005	Bank of India	2000.00
CAL/GEN/43/2005-06	14/02/2006	Lakshmi Vilas bank	1500.00
<b>Total</b>			<b>39000.00</b>

We confirm that firm arrangements of finance through verifiable means towards 100% of the stated means of finance, excluding the amount to be raised through the Issue, have been made.

Any amounts raised in excess of the funds required for the proposed projects and the Issue expenses, will be utilized for general corporate purposes and likewise, if any amount raised is short of the funds required for the proposed projects and the issue expenses, will be funded from internal accruals.

#### Schedule of Project Implementation

Unit	Erection completion / Commissioning in months from "Zero-date"
------	--

Commissioning of SMS no. II, VD along with its auxiliaries	:	15
Commissioning of AOD & Bloom Caster	:	15
Commissioning of Ferro Alloys Division	:	15
Commissioning of Rolling Mill	:	15
Commissioning of Sinter Plant & Oxygen Plant	:	15
Commissioning of CPP No. II	:	18
Start of Private Railway Siding	:	15
Commissioning of Commercial Exploration of Captive Iron Ore Mines	:	27
Commissioning of Commercial Exploration of Captive Coal Mines	:	27

Assumed Zero Date: 01.01.2006

### Year-wise Break-up of Expenditure to be Incurred on the Project

Particulars /Financial Year Ending	Mar-06	Mar-07	Mar-08	Total
<b>Outlay</b>				
Land & Site Development	3.48	11.59	8.11	23.17
Civil & Structural Works	6.40	55.06	2.56	64.02
Plant & Machinery	19.01	171.09	-	190.10
Electrical Installations	6.37	56.07	1.27	63.72
Miscellaneous Fixed Assets	2.67	23.00	1.07	26.75
Contingencies	1.83	15.74	0.73	18.30
Hard Cost:	<b>39.76</b>	<b>332.54</b>	<b>13.75</b>	<b>386.05</b>
Security Deposit	-	2.00	-	2.00
Preliminary Expenses	0.10	0.10	-	0.20
Pre-operative Expenses	2.06	6.18	2.06	10.30
Interest During Construction Period	0.00	11.63	2.33	13.96
Technical Know How Fees	0.33	2.51	0.50	3.34
Margin Money for Working Capital	-	21.50	-	21.50
Total :	<b>42.26</b>	<b>376.45</b>	<b>18.64</b>	<b>437.36</b>
<b>Proposed Funding</b>				
Internal Accruals	42.26	4.29	6.52	53.07
IPO Proceeds	0.00	100.00	-	100.00
Debt	0.00	272.16	12.12	284.28
Total:	<b>42.26</b>	<b>376.45</b>	<b>18.64</b>	<b>437.35</b>

### Step wise implementation schedule of the Steel Division & Other Related Divisions

Item	Date / Expected date of commencement	Date / Expected date of completion
Land	Already Acquired	-
Land Development	December '05	March '06
Civil Works	January '06	January '07
<b>Plant &amp; Machinery &amp; Other Fixed Assets</b>		
Placement of Orders	December '05	April '06
Delivery at site	February '06	December '06

Erection & Installation	March '06	February '07
Power Connection	Already Available	-
Trial Production	March '07	-
Commercial Production	April '07	-

#### Step wise implementation schedule of 2<sup>nd</sup> CPP

Item	Date / Expected date of commencement	Date / Expected date of completion
Land	Already Acquired	-
Land Development	Dec'05	March'06
Civil Works	March'06	April'07
<b>Plant &amp; Machinery &amp; Other Fixed Assets</b>		
Placement of Orders	Dec'05	April'06
Delivery at site	March'06	March'07
Erection & Installation	April'06	May'07
Power Connection	Already Available	-
Trial Production	June'07	-
Commercial Production	July'07	-

#### Step wise implementation schedule of Captive Mines

Item	Date / Expected date of commencement	Date / Expected date of completion
Land	Jan'06	May'06
Land Development	Feb'06	March'08
Civil Works	July'06	Dec'07
<b>Plant &amp; Machinery &amp; Other Fixed Assets</b>		
Placement of Orders	March'06	June'06
Delivery at site	March'07	Jan'08
Erection & Installation	April'07	Feb'08
Power Connection	Jan'08	-
Trial Production	March'08	-
Commercial Production	April'08	-

#### Funds deployed in the Expansion Project.

The total expenditure that has been incurred on the projects, as of January 15, 2006, as certified by ABR & Co., Chartered Accountants, vide their certificate dated February 25, 2006 is as detailed in the table:

Particulars	(Rupees Lacs)
Land & Site Development	7.72
Civil & Structural	1832.45
Plant & Machinery	208.25
Miscellaneous Fixed Assets	18.09
Preoperative Expenses	145.75
<b>Total</b>	<b>2212.26</b>
<b>Source of Finance:</b>	
Internal Resources	1212.26
Unsecured Loans (*)	1000.00
<b>Total</b>	<b>2212.26</b>

(\* ) Unsecured Loan availed from Lakshmi Vilas Bank as per their sanction letter dated December 19, 2005, the terms and conditions of which are inter alia as follows:-

Nature of Facility	Short Term Loan
Rate of Interest	8.5%
Tenor	6 months
Security	Personal Guarantee of Mr. Manoj Kumar Agarwal, Director of AML
Repayment	In single bullet payment at the end of the loan tenor from project term loan being tied up with existing banks/other banks or from internal accruals

### Issue Related Expenses

The Issue related expenses include, among others, underwriting and selling commissions, printing and distribution expenses, legal fees, advertisement expenses, registrar and depository fees. The estimated Issue expenses are as follows:

Activity	Expense (Rs. Lacs)
Lead Management, underwriting and selling commissions	450
Advertising and marketing expenses	127
Printing and Stationary expenses	222
Others (Registrar fees, legal fees etc.)	81
<b>Total estimated Issue expenses</b>	<b>880</b>

### Interim Use of Proceeds

Pending utilisation for the purposes described above, we intend to keep the funds in an escrow account with a scheduled commercial bank in the form of fixed deposits.

### Monitoring of Utilisation of Funds

State Bank of India vide its letter dated February 2, 2006 has agreed to act as the Monitoring Agency for monitoring the utilization of the IPO proceeds. As per regulatory requirements, we will disclose the utilisation of the proceeds of the Issue under a separate head in our Balance Sheet clearly specifying the purpose for which such proceeds have been utilized. We will also, in our Balance Sheet, provide details, if any, in relation to all such proceeds of the Issue that have not been utilised thereby also indicating investments, if any, of such unutilised proceeds of the Issue. We will also make such disclosures as required under the listing agreements entered into with BSE and NSE.

We will pay no part of the proceeds of the Issue as consideration to our Promoters, our directors, key management personnel or companies promoted by our promoters except in the usual course of business.

## TERMS OF THE ISSUE

The Equity Shares being offered are subject to the provisions of the Companies Act, our Memorandum and Articles of Association, the terms of this Prospectus, the Bid cum Application Form, the Revision Form, the Confirmation of Allocation Note and other terms and conditions as may be incorporated in the Allotment advices and other documents/ certificates that may be executed in respect of the Issue. The Equity Shares shall also be subject to laws as applicable, guidelines, notifications and regulations relating to the issue of capital and listing and trading of securities issued from time to time by SEBI, the Government of India, the Stock Exchanges, the RBI, RoC and/ or other authorities, as in force on the date of the Issue and to the extent applicable.

### Ranking of Equity Shares

The Equity Shares being offered shall be subject to the provisions of our Memorandum and Articles of Association and shall rank *pari passu* in all respects with the existing Equity Shares including rights in respect of dividend. The Allottees will be entitled to dividend or any other corporate benefits (including dividend), if any, declared by our Company after the date of Allotment.

### Mode of Payment of Dividend

We shall pay dividend to our shareholders as per the provisions of the Companies Act, 1956.

### Face Value and Issue Price

The Equity Shares with a face value of Rs. 10 each are being offered in terms of this Prospectus at a total price of Rs. 37.00 per Equity Share. At any given point of time there shall be only one denomination for the Equity Shares.

### Rights of the Equity Shareholders

Subject to applicable laws, the equity shareholders shall have the following rights:

- Right to receive dividend, if declared;
- Right to attend general meetings and exercise voting powers, unless prohibited by law;
- Right to vote on a poll either in person or by proxy;
- Right to receive offers for rights shares and be allotted bonus shares, if announced;
- Right to receive surplus on liquidation;
- Right of free transferability;
- Such other rights, as may be available to a shareholder of a listed public company under the Companies Act; and
- Such other rights as may be available to our shareholders under our Memorandum and Articles of Association.

For a detailed description of the main provisions of our Articles of Association dealing with voting rights, dividend, forfeiture and lien, transfer and transmission and/ or consolidation/ splitting, see the section titled “Main Provisions of Articles of Association of the Company” on page 249 of this Prospectus.

### **Market Lot and Trading Lot**

In terms of existing SEBI Guidelines, the trading in the Equity Shares shall only be in dematerialised form for all investors and hence, the tradable lot is one Equity Share. In terms of Section 68B of the Companies Act, the Equity Shares shall be Allotted only in dematerialised form in multiples of one Equity Share subject to a minimum allotment of 150 Equity Shares.

### **Nomination Facility to the Investor**

In accordance with Section 109A of the Companies Act, the sole or First Bidder, along with other joint Bidder(s), may nominate any one person in whom, in the event of death of sole Bidder or in case of joint Bidders, death of all the Bidders, as the case may be, the Equity Shares Allotted, if any, shall vest. A person, being a nominee, entitled to the Equity Shares by reason of the death of the original holder(s), shall in accordance with Section 109A of the Companies Act, be entitled to the same advantages to which he or she would be entitled if he or she were the registered holder of the Equity Share(s). Where the nominee is a minor, the holder(s) may make a nomination to appoint, in the prescribed manner, any person to become entitled to Equity Share(s) in the event of his or her death during the minority. A nomination shall stand rescinded upon a sale/ transfer/ alienation of Equity Share(s) by the person nominating. A buyer will be entitled to make a fresh nomination in the manner prescribed. A fresh nomination can be made only on the prescribed form available on request at the registered office of our Company or at the registrar and transfer agent of our Company.

In accordance with Section 109B of the Companies Act, any person who becomes a nominee by virtue of the provisions of Section 109A of the Companies Act, shall upon the production of such evidence as may be required by our Board, elect either:

- a. to register himself or herself as the holder of the Equity Shares; or
- b. to make such transfer of the Equity Shares, as the deceased holder could have made.

Further, our Board may at any time give notice requiring any nominee to choose either to be registered himself or herself or to transfer the Equity Shares, and if the notice is not complied with, within a period of 90 days, our Board may thereafter withhold payment of all dividends, bonuses or other monies payable in respect of the Equity Shares, until the requirements of the notice have been complied with.

Since the Allotment of Equity Shares in the Issue will be made only in dematerialised mode, there is no need to make a separate nomination with us. Nominations registered with the respective depository participant of the applicant would prevail. If the investors require to change the nomination, they are requested to inform their respective depository participant.

### **Minimum Subscription**

If we do not receive the minimum subscription of 90% of the Net Issue to the extent of the amount including devolvement of Underwriters, within 60 days from the Issue Closing Date, we shall forthwith refund the entire subscription amount received. If there is a delay beyond 8 days after we become liable to pay the amount, we shall pay interest as per Section 73 of the Companies Act.

Further, in accordance with Clause 2.2.2A of the SEBI Guidelines we shall ensure that the number of prospective Allottees to whom the Equity Shares will be Allotted will be not less than 1,000.

## **BASIS FOR ISSUE PRICE**

The Issue Price will be determined by our Company in consultation with the BRLM on the basis of assessment of market demand for the offered Equity Shares by the Book Building Process. The face value of the Equity Shares is Rs. 10 and the Issue Price is 3.7 times the face value at the lower end of the Price Band and 4.2 times the face value at the higher end of the Price Band.

## **QUALITATIVE FACTORS**

### **Professional Management**

The Company is managed by the qualified management team with several years of relevant experience in their domain. The management team is supported by Board of Directors who are qualified and having a vast experience in the industry.

### **Raw material**

Our Company has already received allotment of coal blocks in the Patrapara region in Orissa as per letter no. 13016/33/2005-CA-I dated October 13, 2005. Besides, the Company is expecting to be awarded an iron ore mine shortly in the vicinity of its manufacturing facilities. The State Government of Orissa has forwarded the requisite recommendation vide their letter dated February 9, 2006 to the Govt. of India, Ministry of Mines. This places the Company in an advantageous position vis-à-vis its competitors and would help the Company insulate itself from any market volatilities in terms of fluctuations in the price or availability of key raw materials.

### **Power, Water & Other Utilities**

The Company is in the process of constructing a 12 MW waste heat based captive power plant, the expected date of commissioning of which is April 2006. The project under implementation envisages the establishment of a similar waste heat based power plant of a capacity of 18 MW. Hence, the Company will have access to a cheap and reliable source of power for its operations. The Company has drawn a 11 km pipeline to draw water to a reservoir inside the manufacturing facilities of the Company. The reservoir has the capacity to store up to 7 days of the plant's water requirement. Besides, the Company proposes to construct a captive railway siding as a part of the project under implementation. Access to these utilities will enable the Company to be competitive and economical in its production process.

### **Operations & Maintenance**

The Company has installed state of the art machinery and monitoring equipment. The Company has trained personnel who maintain and operate the machines. Also all the key imported equipment suppliers have their service centers in India and thereby the Company is assured of spares and help, if required. The Company has been recognised at various forums for its performance in Exports and cost reduction measures.

### **Strong customer relationships**

The Adhunik Group has developed a loyal customer base over the last 10 years. The Company, being the flagship of the Adhunik Group will derive advantage from the brand equity and goodwill created by the Group and will benefit from the customer base already in place for the products of the Company.

### **Quality Standards**

The Company adheres strict quality standards in respect of the process of production and end-products. The Company has obtained ISO 9001-2000 certification for its manufacturing facilities.

## **QUANTITATIVE FACTORS**

The Information about us that has been presented in this section is derived from our restated financial statements prepared in accordance with Indian GAAP.

Some of the quantitative factors, which may form the basis for computing the Issue Price, are as follows:

**1. Earning Per Share (EPS) of face value of Rs. 10**

Year	Adjusted EPS (Rs.)	Weight
FY 2003	0.00 (*)	1
FY 2004	3.35	2
FY 2005	2.06	3
<b>Weighted Average</b>	2.15	
Nine months ended on 31/12/2005 (Annualised)	3.91	

(\*) Negligible

**2. Price/Earning (P/E) ratio in relation to Issue Price of Rs. 37.00**

- (i) Based on EPS of Rs. 3.91 for the nine months ended on 31/12/2005(annualized): 9.46
- (ii) Industry P/E:

Highest	28.1
Lowest	1.5
Average	4.4

(Source: Capital Market, Vol.: XX/21; Dec. 19,2005-Jan 1, 2006 sector: Steel-Large)

**3. Return on Net Worth (RoNW)**

Year	RoNW (%) *	Weight
FY 2003	0.00	1
FY 2004	0.15	2
FY 2005	1.85	3
<b>Weighted Average</b>	0.98	

\* RoNW has been calculated as the ratio of Net profit after tax to Net Worth where:

- i. Net Profit after tax is the Net Profit after tax and preference dividend as attributable to the equity shareholders; and
- ii. Net worth is the equity shareholders fund (i.e., Net Worth as shown in the Annexure VIII to the Report on the Restated Financial Statements, *minus*, Preference Share Capital, premium payable on redemption of Preference share capital and miscellaneous expenditure to the extent not written off).

**4. Minimum return on increased Net Worth required to maintain pre-Issue EPS of Rs.2.06: 9.00**

**5. Net Asset Value per share (NAV)**

	NAV (Rs)
As on March 31, 2005	14.33
As on December 31, 2005	18.30
After the Issue	23.84
Issue Price*	37.00

### Comparison of with industry peers

Our Company proposes to manufacture alloy/specialty steel and primarily autograde steel. There are no listed companies of comparable size operating exclusively in this niche segment. Hence our financials are not strictly comparable to any other listed companies operating in this segment.

Financial performance of some of the key players in this segment are given in the table below:

*(in Rs. Crores)*

	Name of Company				AVERAGE
	Mukand Limited	Sunflag	Usha Martin	Kalyani	
FY ENDED	2005	2005	2005	2005	
Net Worth	301.98	236.76	450.77	245.23	308.69
Gross Block	992.55	511.93	1386.43	281.69	793.15
Net Sales	1523.78	788.98	1167.39	761.19	1060.34
PAT	185.73	34.83	40.87	43.01	76.11
Book Value (Rs.)	41.30	14.60	121.31	58.26	58.87
EPS (Rs.)	25.40	2.15	10.79	9.94	12.07
D/E Ratio	5.51	0.69	1.94	0.61	2.19
P/E	3.24	6.81	15.78	28.08	13.48

The face value of the equity shares of our Company is Rs. 10/- and the issue price is 3.70 times of the Face Value. Issue Price of Rs. 37 has been determined by our Company in consultation with the BRLMs, on the basis of the assessment of market demand for the Equity Shares by way of Book Building and is justified on the basis of the above factors.

Investors are advised to refer to the section titled “ Risk Factors” on page no. vii of this Prospectus and the financials of the Company including important profitability and return ratios as set out in the Auditors’ Report on page no. 148 of this Prospectus to have a more informed view.

## STATEMENT OF TAX BENEFITS

Adhunik Metaliks Limited  
14 N.S Road,  
Kolkata -700 001.

Dear Sirs,

### **Statement of Possible Tax Benefits available to the Company and its shareholders**

We hereby report that the enclosed statement states the possible tax benefits available to the Company and to the shareholders of the Company under the Income Tax Act, 1961, Wealth Tax Act, 1957 and the Gift Tax Act, 1958, presently in force in India. Several of these benefits are dependent on the Company or its shareholders fulfilling the conditions prescribed under the relevant provisions of the statute. Hence, the ability of the Company or its shareholders to derive the tax benefits is dependent upon their fulfilling such conditions, which based on business imperatives the Company faces in the future, the Company may or may not choose to fulfill.

The benefits discussed in the enclosed statement are not exhaustive. This statement is only intended to provide general information to the investors and is neither designed nor intended to be a substitute for professional tax advice. In view of the individual nature of the tax consequences and the changing tax laws, each investor is advised to consult his or her own tax consultant with respect to the specific tax implications arising out of their participation in the issue.

We do not express any opinion or provide any assurance as to whether:

- i) the Company or its share holders will continue to obtain these benefits in future; or
- ii) the conditions prescribed for availing the benefits have been / would be met with.

The contents of the enclosed statement are based on information, explanations and representations obtained from the Company and on the basis of their understanding of the business activities and operations of the Company.

### **S.R. Batliboi & Company Chartered Accountants**

Per

RAHUL ROY

*a Partner*

Membership No. 53956

22, Camac Street,  
Block 'C', 3<sup>rd</sup> floor,  
Kolkata : 700016

Dated : February 24, 2006

## **STATEMENT OF TAX BENEFITS**

The tax benefits listed below are the possible benefits available under the current tax laws in India. Several of these benefits are dependent on the Company or its Shareholders fulfilling the conditions prescribed under the relevant tax laws. Hence the ability of the Company or its Shareholders to derive the tax benefits is dependent upon fulfilling such conditions, which based on business imperatives it faces in the future, it may not choose to fulfill.

The following tax benefits shall inter alia, be available to the Company and the prospective shareholders under Direct Tax.

### **1. To the Company - Under the Income-tax Act, 1961 (the Act)**

- a) Under Section 35D of the Act, the Company will be entitled to a deduction equal to 1/5th of the expenditure incurred of the nature specified in the said section, including expenditure incurred on present issue, such as under writing, commission, brokerage and other charges as specified in the provision, by way of amortization over a period of 5 successive years, beginning with the previous year in which the new unit commences production, subject to the stipulated limits.
- b) In terms of Section 115 JAA (1A) of the Act tax credit shall be allowed for any Assessment Year commencing on or after April 01, 2006. Credit eligible for carry forward is the difference between MAT paid and the tax computed as per the normal provisions of the Act. The credit is available for set off only when tax becomes payable under the normal provisions and that tax credit can be utilized to set-off any tax payable under the normal provisions in excess of MAT payable for that relevant year. Such MAT credit shall not be available for set-off beyond 5 years succeeding the year in which the MAT credit initially arose.
- c) Under Section 32 of the Act, the Company can claim depreciation allowance at the prescribed rates on tangible assets such as building, plant and machinery, furniture and fixtures, etc. and intangible assets such as patent, trademark, copyright, know-how, licenses, etc. if acquired after March 31, 1998. In terms of Clause (iia) of sub-section (1) of Section 32 of the Act, the Company is entitled to further deduction of 20% as additional depreciation on new plant & machinery acquired and installed after March 31, 2005, subject to conditions specified therein.

### **2. To the Members of the Company – Under the Act**

#### **2.1 Resident Members**

- a) Under Section 10(34) of the Act, income earned by way of dividend from domestic company referred to in Section 115-O of the Act is exempt from income-tax in the hands of the shareholders.
- b) Under Section 10(38) of the Act, long term capital gain arising to the shareholder from transfer of a long term capital asset being an equity share in the company (i.e. capital asset held for the period of more than twelve months) entered into in a recognized stock exchange in India and being such a transaction, which is chargeable to Securities Transaction Tax, shall be exempt from tax.

- c) In terms of Section 88 E of the Act, the Securities Transaction Tax paid by the shareholder in respect of the taxable securities transactions entered into in the course of the business would be eligible for rebate from the amount of income-tax on the income chargeable under the head 'Profits and Gains of Business or Profession' arising from taxable securities transactions.
- d) As per the provisions of Section 10(23D) of the Act, all mutual funds set up by public sector banks, public financial institutions or mutual funds registered under the Securities and Exchange Board of India (SEBI) or authorized by the Reserve Bank of India are eligible for exemption from income-tax, subject to the conditions specified therein, on their entire income including income from investment in the shares of the company.
- e) Under Section 54EC of the Act, capital gain arising from transfer of long term capital assets (other than those exempt under Section 10 (38) of the Act) shall be exempt from tax, subject to the conditions and to the extent specified therein, if the capital gain are invested within a period of six months from the date of transfer in the bonds redeemable after three years and issued by:
  - i) National Bank for Agriculture and Rural Development established under Section 3 of the National Bank for Agriculture and Rural Development Act, 1981;
  - ii) National Highways Authority of India constituted under Section 3 of National Highways Authority of India Act, 1988;
  - iii) Rural Electrification Corporation Limited, a company formed and registered under the Companies Act, 1956;
  - iv) National Housing Bank established under Section 3(1) of the National Housing Bank Act, 1987; and
  - v) Small Industries Development Bank of India established under Section 3(1) of the Small Industries Development Bank of India Act, 1989.

If only part of the capital gain is so reinvested, the exemption shall be proportionately reduced. However, the amount so exempted shall be chargeable to tax subsequently, if the new bonds are transferred or converted into money within three years from the date of their acquisition.

- f) Under Section 54ED of the Act, capital gain arising from transfer of long term capital assets, being listed securities or units (other than those exempt under Section 10(38) of the Act), shall be exempt from tax, subject to the conditions and to the extent specified therein, if the capital gain is invested in public issue of equity shares issue of an Indian Public Company within a period of six months from the date of such transfer. If only a part of the capital gain is so reinvested, the exemption shall be proportionately reduced. However, the amount so exempted shall be chargeable to tax subsequently, if the new equity shares are transferred or converted into money within one year from the date of their acquisition.
- g) Under Section 54F of the Act, where in the case of an individual or HUF capital gain arise from transfer of long term assets (other than a residential house and those exempt under Section 10(38) of the Act) then such capital gain, subject to the conditions and to the extent specified therein, will be exempt if the net sales consideration from such transfer is utilized for purchase of residential house property within a period of one year before or two year after the date on which the transfer took place or for construction of residential house property within a period of three years after the date of transfer. If only

a part of the net consideration is so reinvested, the exemption shall be proportionately reduced.

- h) Under Section 111A of the Act, capital gains arising from transfer of short term capital assets, being an equity share in a company which is subject to Securities Transaction Tax will be taxable under the Act at the rate of 10% (plus applicable surcharge and education cess).
- i) Under Section 112 of the Act and other relevant provisions of the Act, long term capital gains (not covered under Section 10(38) of the Act) arising on transfer of shares in the Company, if shares are held for a period exceeding 12 months, shall be taxed at a rate of 20% (plus applicable surcharge and education cess on income-tax) after indexation as provided in the second proviso to Section 48 or at 10% (plus applicable surcharge and education cess on income-tax) (without indexation), at the option of the Shareholders.

## **2.2 Non Resident Indians/Members other than Foreign Institutional Investors and Foreign Venture Capital Investors**

- a) By virtue of Section 10(34) of the Act, income earned by way of dividend income from a domestic company referred to in Section 115-O of the Act, is exempt from tax in the hands of the recipients.
- b) Under Section 10(38) of the Act, long term capital gain arising to the shareholder from transfer of a long term capital asset being an equity share in the company (i.e. capital asset held for the period of more than twelve months) entered into in a recognized stock exchange in India and being such a transaction, which is chargeable to Securities Transaction Tax, shall be exempt from tax.
- c) In terms of Section 88 E of the Act, the Securities Transaction Tax paid by the shareholder in respect of the taxable securities transactions entered into in the course of the business would be eligible for rebate from the amount of income-tax on the income chargeable under the head 'Profits and Gains of Business or Profession' arising from taxable securities transactions.
- d) Under the first proviso to Section 48 of the Act, in case of a non resident, in computing the capital gains arising from transfer of shares of the company acquired in convertible foreign exchange (as per exchange control regulations), protection is provided from fluctuations in the value of rupee in terms of foreign currency in which the original investment was made. Cost indexation benefits will not be available in such a case.
- e) Under Section 54EC of the Act, capital gain arising from transfer of long term capital assets (other than those exempt under Section 10(38) of the Act) shall be exempt from tax, subject to the conditions and to the extent specified therein, if the capital gain are invested within a period of six months from the date of transfer in the bonds redeemable after three years and issued by –
  - i) National Bank for Agriculture and Rural Development established under Section 3 of the National Bank for Agriculture and Rural Development Act, 1981;

- ii) National Highways Authority of India constituted under Section 3 of National Highways Authority of India Act, 1988;
- iii) Rural Electrification Corporation Limited, a company formed and registered under the Companies Act, 1956;
- iv) National Housing Bank established under Section 3(1) of the National Housing Bank Act, 1987; and
- v) Small Industries Development Bank of India established under Section 3(1) of the Small Industries Development Bank of India Act, 1989.

If only part of the capital gain is so reinvested, the exemption shall be proportionately reduced. However, the amount so exempted shall be chargeable to tax subsequently, if the new bonds are transferred or converted into money within three years from the date of their acquisition.

- f) Under Section 54ED of the Act, capital gain arising from transfer of long term capital assets, being listed securities or units (other than those exempt under Section 10(38) of the Act), shall be exempt from tax, subject to the conditions and to the extent specified therein, if the capital gain is invested in public issue of equity shares issue of an Indian Public Company within a period of six months from the date of such transfer. If only a part of the capital gain is so reinvested, the exemption shall be proportionately reduced. However, the amount so exempted shall be chargeable to tax subsequently, if the new equity shares are transferred or converted into money within one year from the date of their acquisition.
- g) Under Section 54F of the Act, where in the case of an individual or HUF capital gain arise from transfer of long term assets (other than a residential house and those exempt under Section 10(38) of the Act) then such capital gain, subject to the conditions and to the extent specified therein, will be exempt if the net sales consideration from such transfer is utilized for purchase of residential house property within a period of one year before or two year after the date on which the transfer took place or for construction of residential house property within a period of three years after the date of transfer. If only a part of the net consideration is so reinvested, the exemption shall be proportionately reduced.
- h) Under Section 111A of the Act, capital gains arising from transfer of short term capital assets, being an equity share in a company which is subject to Securities Transaction Tax will be taxable under the Act at the rate of 10% (plus applicable surcharge and education cess).
- i) Under Section 112 of the Act and other relevant provisions of the Act, long term capital gains (not covered under Section 10(38) of the Act) arising on transfer of shares in the Company held for a period exceeding 12 months, shall be taxed at applicable rates.
- j) **Special provisions relating to non resident Indians for taxation of Income from investment and Long Term Capital Gains on its transfer**
  - i) A non-resident Indian, i.e. an individual being a citizen of India or person of Indian origin has an option to be governed by the special provisions contained in Chapter XIII A of the Act, i.e. "Special Provisions Relating to certain incomes of Non-Residents".

- ii) Under Section 115E of the Act, where shares in the company are subscribed for in convertible Foreign Exchange by a non-resident Indian, capital gains arising to the non resident on transfer of shares held for a period exceeding 12 months shall (in cases not covered under Section 10(38) of the Act) be concessionaly taxed at a flat rate of 10% (plus applicable surcharge and education cess) without indexation benefit but with protection against foreign exchange fluctuation under the first proviso to Section 48 of the Act.
- iii) Under provisions of Section 115F of the Act, long term capital gains (not covered under Section 10(38) of the Act) arising to a non-resident Indian from the transfer of shares of the company subscribed to in convertible Foreign Exchange shall be exempt from income tax if the net consideration is reinvested in specified assets within six months of the date of transfer. If only part of the net consideration is so reinvested, the exemption shall be proportionately reduced. The amount so exempted shall be chargeable to tax subsequently, if the specified assets are transferred or converted within three years from the date of their acquisition.
- iv) Under provisions of Section 115-G of the Act, it shall not be necessary for a non-resident Indian to furnish his return of income if his only source of income is investment income or long term capital gains or both arising out of assets acquired, purchased or subscribed in convertible foreign exchange and tax deductible at source has been deducted therefrom.
- v) Under Section 115-I of the Act, a non resident Indian may elect not to be governed by the provisions of Chapter XII-A of the Act for any assessment year by furnishing his return of income under Section 139 of the Act declaring therein that the provisions of the Chapter shall not apply to him for that assessment year and if he does so the provisions of this Chapter shall not apply to him. In such a case the tax on investment income and long term capital gains would be computed as per normal provisions of the Act.

### **2.3 Foreign Institutional Investors (FIIs)**

- a) By virtue of Section 10(34) of the Act, income earned by way of dividend income from another domestic company referred to in Section 115-O of the Act, are exempt from tax in the hands of the institutional investor.
- b) Under Section 10(38) of the Act, long term capital gain arising to the shareholder from transfer of a long term capital asset being an equity share in the company (i.e. capital asset held for the period of more than twelve months) entered into in a recognized stock exchange in India and being such a transaction, which is chargeable to Securities Transaction Tax, shall be exempt from tax.
- c) Under Section 115AD capital gain arising on transfer of long term capital assets, being shares in a company (other than those mentioned in point b) above), are taxed at the rate of 10% (plus applicable surcharge and education cess). Such capital gains would be computed without giving effect to the first and second proviso to Section 48 of the Act. In other words, the benefit of indexation, direct or indirect, as mentioned under the two provisos would not be allowed while computing the capital gains.

- d) Under Section 111A of the Act, capital gains arising from transfer of short term capital assets, being an equity share in a company which is subject to Securities Transaction Tax will be taxable under the Act at the rate of 10% (plus applicable surcharge and education cess).

Short term capital gains on transfer of shares other than those mentioned above would be taxable at the rate of 30% (plus applicable surcharge and education cess).

- e) In terms of Section 88 E of the Act, the Securities Transaction Tax paid by the shareholder in respect of the taxable securities transactions entered into in the course of the business would be eligible for rebate from the amount of income-tax on the income chargeable under the head 'Profits and Gains of Business or Profession' arising from taxable securities transactions.
- f) Under Section 54EC of the Act, capital gain arising from transfer of long term capital assets (other than those exempt under section 10(38) of the Act) shall be exempt from tax, subject to the conditions and to the extent specified therein, if the capital gain are invested within a period of six months from the date of transfer in the bonds which are redeemable after 3 years and issued by –
- i) National Bank for Agriculture and Rural Development established under Section 3 of the National Bank for Agriculture and Rural Development Act, 1981;
  - ii) National Highways Authority of India constituted under Section 3 of National Highways Authority of India Act, 1988;
  - iii) Rural Electrification Corporation Limited, a company formed and registered under the Companies Act, 1956;
  - iv) National Housing Bank established under Section 3(1) of the National Housing Bank Act, 1987; and
  - v) Small Industries Development Bank of India established under Section 3(1) of the Small Industries Development Bank of India Act, 1989.

If only part of the capital gain is so reinvested, the exemption shall be proportionately reduced. However, the amount so exempted shall be chargeable to tax subsequently, if the new bonds are transferred or converted into money within three years from the date of their acquisition.

- g) Under Section 54ED of the Act, capital gain arising from transfer of long term capital assets, being listed securities or units (other than those exempt under Section 10(38) of the Act), shall be exempt from tax, subject to the conditions and to the extent specified therein, if the capital gain is invested in public issue of equity shares issue of an Indian Public Company within a period of six months from the date of such transfer. If only a part of the capital gain is so reinvested, the exemption shall be proportionately reduced. However, the amount so exempted shall be chargeable to tax subsequently, if the new equity shares are transferred or converted into money within one year from the date of their acquisition.

## **2.4 Venture Capital Companies / Funds**

As per the provisions of Section 10(23FB) of the Act, income of

- Venture Capital Company which has been granted a certificate of registration under the Securities and Exchange Board of India Act, 1992 and fulfilling such conditions as may be notified in the Official Gazette; and
- Venture Capital Fund, operating under a registered trust deed or a venture capital scheme made by Unit Trust of India, which has been granted a certificate of registration under the Securities and Exchange Board of India Act, 1992 and fulfilling such conditions as may be notified in the Official Gazette;

which is set up for raising funds for investment in a Venture Capital Undertaking, is exempt from income tax.

### **3. Wealth Tax Act, 1957**

Shares in a company held by a shareholder will not be treated as an asset within the meaning of Section 2(ea) of Wealth-tax Act, 1957; hence, wealth tax is not leviable on shares held in a company.

### **4. The Gift Tax Act, 1958**

Gift of shares of the company made on or after October 1, 1998 are not liable to tax.

### **Notes**

- a) All the above benefits are as per the current tax law and will be available only to the sole/ first named holder in case the shares are held by joint holders.
- b) In respect of non-residents, taxability of capital gains mentioned above shall be further subject to any benefits available under the Double Taxation Avoidance Agreement, if any between India and the country in which the assessee is a tax resident.
- c) In view of the individual nature of tax consequence, each investor is advised to consult his/ her own tax adviser with respect to specific tax consequences of his/ her participation in the scheme.

## INDUSTRY OVERVIEW

*The information presented in this section has been extracted from publicly available documents, which have not been prepared or independently verified by the Company, the Lead Manager or any of their respective affiliates or advisors or the sources referred to herein.*

*In this Section, we have relied on and referred to information regarding the industry and competitors from market research reports, and other publicly available sources. Although we believe that this information is reliable, we have not independently verified the accuracy and completeness of the information. We caution you not to place undue reliance on this data.*

Alloy and special steels are characterised by their enhanced properties caused due to presence of one or more alloying elements such as Manganese, Silicon, Nickel, Chromium, Molybdenum, Vanadium, Micro alloy grain structure etc. In order to impart special characteristics, varying percentages of alloying elements are added to produce alloy and special steels. There are more than 60 grades of stainless steel. However, the entire group can be divided into five classes. Each is identified by the alloying elements which affect their microstructure and for which each is named. The vast majority of steel produced in the world is carbon and alloy steel, with the more expensive stainless steels representing a small, but valuable niche market.

In the last few years, application of alloy steel is increasing in consumer items as well as consumer durables and automobiles. Use of alloy steels has enabled the industry to make the machinery light in weight thus making them energy efficient. Use of alloy steels in two wheelers and four wheelers has enabled automobile manufacturers to produce lighter and fuel-efficient vehicles. The following chart provides a snapshot of the sector wise break-up of the demand for alloy and special steel in India during 2004-05.

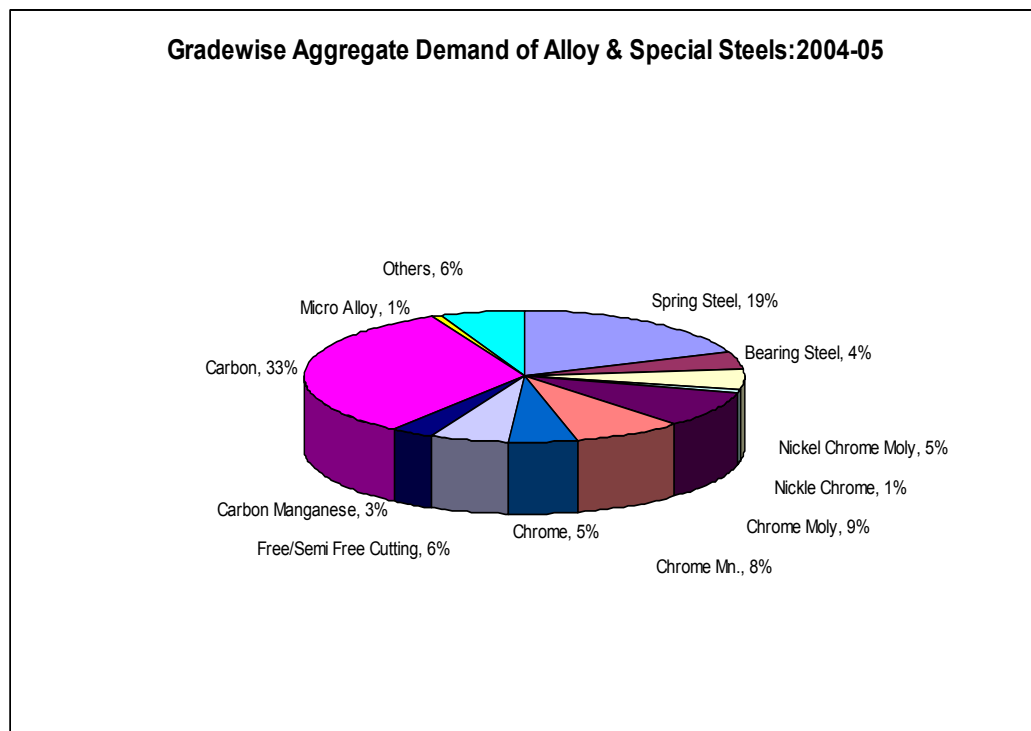

**(Source: Industrial Development Services Pvt Ltd, New Delhi, December 2005)**

## The Alloy and Special Steel Industry in India

According to Industrial Development Services Private Ltd, New Delhi (a firm engaged in engineering and economic consultancy) there are 19 recognized units engaged in the manufacture of alloy and special steels with an installed capacity of almost 2.8 million tonnes per annum. Out of these Visvesvaraya Iron & Steel Plant (VISP), Southern Iron & Steel Co. Ltd. (SISCOL), Kalyani Steels Ltd. (KSL), Usha Martin Ltd. (UML) are based on MBFs. In addition to these Mukand also gets 58 per cent of the production of semis at Hospet Steel, which is also based on MBF. Sunflag is based on sponge iron route, starting from iron ore itself. All the remaining recognized alloy and special steel producers are based on EAF technology. AML is positioning itself in the present scenario as the most cost effective producer of special and alloy steel. AML is also going for most cost effective route to produce special and alloy steel.

An analysis of the production of alloy and special steels in India in 2004-05 showed the following results:

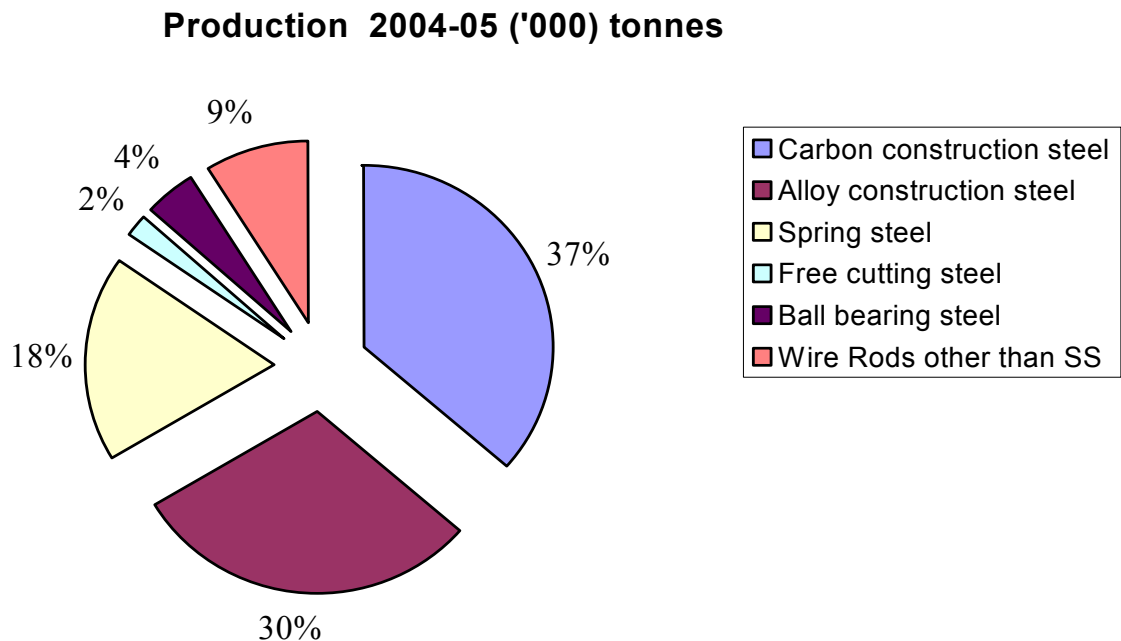

*(Source: Industrial Development Services Pvt Ltd, New Delhi, Market Research Report, December 2005)*

Demand for Auto Grade Special Steel has reached at approximately 2 Mn tonnes on account of the buoyancy in Auto Ancillary sector. The current upswing in the said sector (which is the major customer of Auto grade Special Steel) is expected to continue in the medium term. The Automotive Component Manufacturers Association (ACMA) expects the domestic Auto Component growth at a CAGR of 15% till FY 2012.

Leading global component majors are planning to set up shop in India to cash in on the booming industry growth trends. The basic rationale for the large scale shifting of manufacturing facilities to India lies in low labour costs and high quality engineering skills in auto ancillary manufacturing. Some high profile global auto component dealers and manufactures have set their sights on India. The US based Textron Fastening Systems is one of the market leader in fastening and assembly products, while Precision Cast parts is a

diversified manufacture of complex metal components and products for aero space, power generation, automotive, general industrial and other markets. The Canada based Magna International is a supplier of automotive systems and components for Original Equipment Manufactures (OEMs). Demand in the Indian auto components industry is growing at a rate of about 25-30% annually, while the automotive sector grew 12% last year. The prospect of export from India is also a major attraction. The global majors are interested in exporting back low cost good quality products to their global factories and other markets to reduce overall costs. Export of auto components from India have grown at a compounded growth rate of 19% over the past six years. During fiscal '04, the industry achieved a milestone of \$1bn worth of exports.

*(Source: Economic Times of India, 14 December'2005)*

Keeping in view the growth rate and interests of global players the Government has also indicated the need to set up Auto Hubs in the various parts of the country so as to meet the global demand.

According to Industrial Development Services Private Ltd, New Delhi, the aggregate domestic demand for different categories of alloy and special steel is likely to increase from 2.45 million tones in 2004-05 to almost 5.2 million tones per annum by the year 2013-14, at a CAGR of 8.7%.

The last financial year has been a landmark year for the Indian auto industry. For the first time, total sales of passenger vehicles in the country exceeded the 1 million mark. During 2004 the Indian auto components industry's exports touched around \$1B. Between FY98 & FY04, exports have grown at a CAGR of 25%. FY05 figures are estimated at \$1.4B. According to a McKinsey report, exports are expected to touch \$25 billion by 2015.

ACMA expects exports to reach \$5 billion by 2010. The global auto component market is currently estimated at \$1 trillion with OEMs accounting for 70% of this market and the balance being represented by the replacement market. By 2015, approximately 25-30% of the total requirement of auto components is expected to be sourced from low cost countries such as India, China, Brazil, Mexico, East Europe, etc. Indian manufacturers are now in a position to offer a complete range of engineering solutions including analysis & simulation, modeling & drafting, tooling design etc. India is fast becoming the hub for the \$1 trillion global auto-component industry.

*(Source: HDFC Sec. Research, August 2004)*

The current landscape in the Alloy and Special Steel sector in India can be summarized as depicted in the following Table. The total capacity of this industry is 2.8 million tonnes per annum.

Name of the Unit/Location	Installed Capacity ('000 tonnes p.a.)	Current Production ('000 tonnes p.a.)	Main Products	Technology
Aarti Steel Ltd., Ludhiana (excluding IF Capacity)	100	65	Forging quality steel	EAF/VD/CC
Alloy Steel Plant, Durgapur	164	90	Full range of alloy and special steel	EAF/VAD/CC & ingots
Bhushan Ltd., Chandigarh	30	25	Forging quality steel	EAF/CC
Ferro Alloys Corporation, Nagpur	50	10	Forging quality steel, ball bearing quality steel and SS	EAF/VD/CC and AOD for Stainless Steel
Indian Seamless Steel & Alloys Ltd., Baramati	240	200	Forging quality steel, ball bearing quality steel, seamless pipe quality steel	EAF/VD/CC
Jindal Steel & Power Ltd., Raigarh	400	140	Billets for forging quality steel, wire rods and seamless steel pipes	MBF/EAF/VD/CC
Kalyani Carpenter Special Steel Ltd., Pune	150	100	Forging quality steel, ball bearing quality steel, specialized and high alloy steels	EAF/VD/CC and Ingots
Kalyani Steels Ltd., Hospet	150	100	Forging quality steel, seamless pipe quality steel	MBF/EOF/VD/CC
Mahindra UGINE Steel Co. Ltd., Khopoli	105	90	Full range	EAF/VD/CC and ingots
Marmagao Steels Ltd., Goa	75	50	Spring Steel	EAF/CC
Modern Steels Ltd., Mandi, Gobindgar	72	40	Forging quality steel, spring steel	EAF/CC
Mukand Ltd.	250	150	Forging quality steel, wire rods, SS	The company obtains billets from Kalyani, Hospet. In addition, it has EAF/VD/CC at Kalve
Remi Metals Gujarat Ltd., Bharuch	72	40	Forging quality steel	EAF/VD/CC
Southern Iron & Steel Co. Ltd., Salem	250	30	Wire rods, spring steel	MBF/EOF/CC
Sunflag Iron & Steel Ltd., Bhandara	200	200	Spring steel, forging quality steel, wire rods, SS	EAF/VD/CC
Upper (I) Steel Mfg & Engg Co. Ltd., Ludhiana	72	50	Forging quality steel, spring steel, file steel	EAF/VD/CC
Usha Martin Ltd., Jamshedpur	200	100	Wire rods and forging quality steel	MBF/EAF/CC
Vardhaman Special Steel, Ludhiana	70	65	Forging quality steel	EAF/VD/CC
Visvesvaraya Iron & Steel Plant, Bhadravati	150	90	Full range of alloy and special steel	MBF/BOF/EAF/VD & CC

Source: Market Survey for Alloy Steels carried out by Industrial Development Services Pvt. Ltd., December, 2005

After implementation of proposed expansion program AML will be among the few players to make special and alloy steel through most cost effective route. The proposed production facilities of AML will be engaged in the production of spring steel, forging quality steel, ball bearing quality steel, stainless steel, specialized and high alloy steel etc. For further details please refer to page 77 of the prospectus.

The technology proposed to be used by AML consists of MBF/ EAF/VD/AOD/LF/CC route. Further, the plant is backwardly integrated by way of captive power plant, coal washery, DRI, sinter plant, captive iron ore and coal mines.

The rationale for the Company's decision to enter into the high tech, high value added auto grade steel products including EN 16, EN 17, EN 18, EN 19, EN 45A, 50CRV4 and 58 CRV4 besides the low carbon, plain carbon and high carbon steel is its exciting growth potential. The Company's mission is to create facilities for manufacture of world class steel at globally competitive prices.

***Outlook of Alloy and Special Steel (Sector Wise)***

The following sections analyze the trend of sector wise demand for alloy and special steels in an industry-wise manner.

***A) Auto Grade Alloy and Special Steel***

As already stated, automobiles industry is the largest consumer of alloy and special steels. Most of the requirements of alloy and special steels for the automotive sectors and tractors are routed through intermediate processors like steel forging units, bright bar industries, spring industries and auto ancillaries. The detail discussion for each of these sectors is given under.

***i) Steel Forging Industry***

The forging industry is the largest consuming sector for alloy and special steels. A large share of output of the forging units finds application in the automotive/auto ancillary sector, both for OEMs as well as for replacement requirements. In addition to the stand alone forging units, a few units have captive forging facilities. The most prominent amongst these is TATA MOTORS, Jamshedpur. Hindustan Motors also has a captive forge shop consuming small quantities of alloy and special steels. Other than the automotive sector, the end-users which account for significant consumption of steel forgings include railway rolling stock, defence, agriculture and industrial machinery.

The current aggregate installed capacity of the steel forging industry is estimated at around 800,000 tpa. The table below gives the actual production of steel forgings over the last six years:

<b>YEAR</b>	<b>PRODUCTION (in thousand tpa)</b>
FY 00	497
FY 01	435
FY 02	382
FY 03	440
FY 04	550
FY 05	645

*(source: Industrial Development Services Pvt Ltd, New Delhi, Market Survey Report, December 2005)*

Almost all the existing alloy and special steel plants in the country manufacture forging quality steels. Major players catering to this market segment include Vardhman, Aarti Steel, Modern Steel, and Bhusan Steels Limited in the Northern region, ASP, Durgapur in the Eastern Region, ISSAL, Kalyani Carpenter, MUSCO, Mukund, REMI Metals and Sunflag in the Western region and VISP and Kalyani Steel in the Southern region. The industry consumes a wide variety of alloy and special steels. Major share of the requirements fall in the size range of 25-140 mm dia for rounds and 45 to 140 mm RCS.

Average consumption of alloy and special steel forgings for various categories of vehicles is as follows:

Category	Average Consumption/Vehicle (Kg.)
Medium & Heavy Commercial Vehicles	650/800
Light Commercial Vehicles	300
Passengers Cars	
- Large Cars	80
- Medium Cars	70
- Small Cars	55
Multi – Utility Vehicles	200
Three – Wheelers	
- Scooters	18
- Motorcycles	8
- Mopeds	5
Tractors	400

(source: Industrial Development Services Pvt Ltd, New Delhi, Market Survey Report, December 2005)

The projections of demand for alloy and special steel forging for various categories of automobiles for the coming years is shown below:

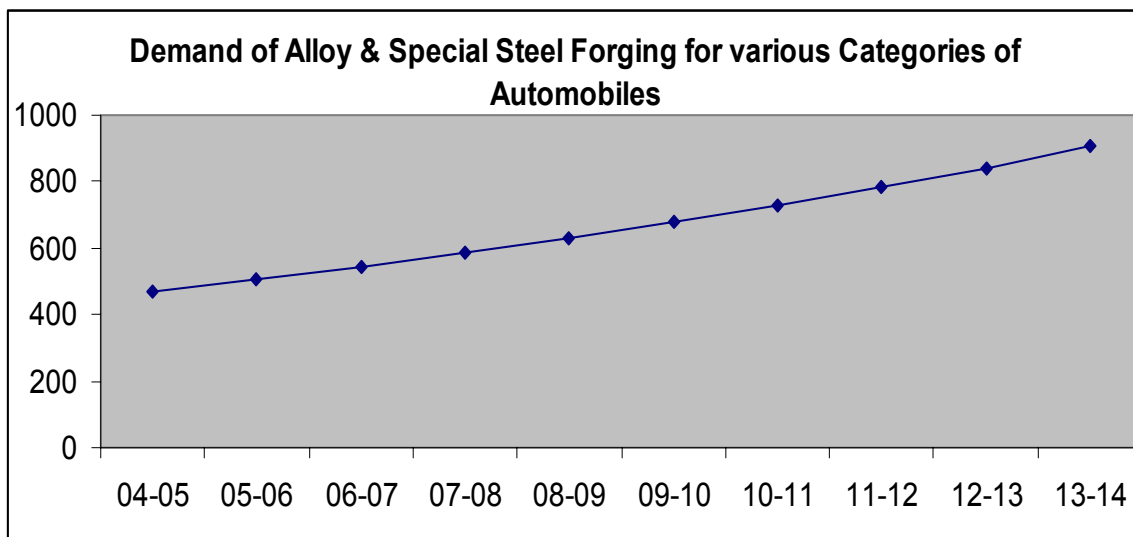

(Figures in Thousand tonnes)

(source: Industrial Development Services Pvt Ltd, New Delhi, Market Survey Report, December 2005)

### ii) Spring Industry

Production of leaf and other springs is spread both in the medium/large scale industrial units as well as small scale sector. The current production of spring steels in the country is estimated at around 35,000 tpm. Of this 3,000 to 4,000 tonnes per month of spring steels flats are being exported by Sunflag. Marmagao Steel and RS Steel are also exporting small quantities of spring steel flats. Earlier, there were no imports of spring steels. Recently, around 6,000 tonnes of spring steel flats have been imported from China by Tata Motors, Ashok Leyland and Friends Auto. The unit wise production capacity of spring steel during FY05 is given in the table below:

NAME OF THE UNIT	CAPACITY (tpm)
<b>EAF UNITS:</b>	
Sunflag	7,000
Upper India	2,500
Modern Steel	1,500
SISCOL	2,000
Marmagoa Steel	5,500
Others (Mukand, VISP, Usha Martin etc.)	500
<b>SUB TOTAL</b>	<b>19,000</b>
<b>INDUSTION FURNACE UNITS &amp; RINL</b>	<b>17,000</b>
<b>TOTAL</b>	<b>36,000</b>

(source: Industrial Development Services Pvt Ltd, New Delhi, Market Survey Report, December 2005)

In addition to the OE requirements, substantial quantities of steels are required every year for replacement purpose. Around 5,000 tpm of Spring Steel currently exported either directly or in the form of furnace spring sets. The demand for spring steel is likely to increase from about 428 thousand tonnes during the year 2004-05 to almost 666 thousand tonnes per annum by the year 2013-14, at an ACGR of around 5% per annum.

The future demand of alloy and special steel for this sector till the year 2013-14 has been estimated as follows:

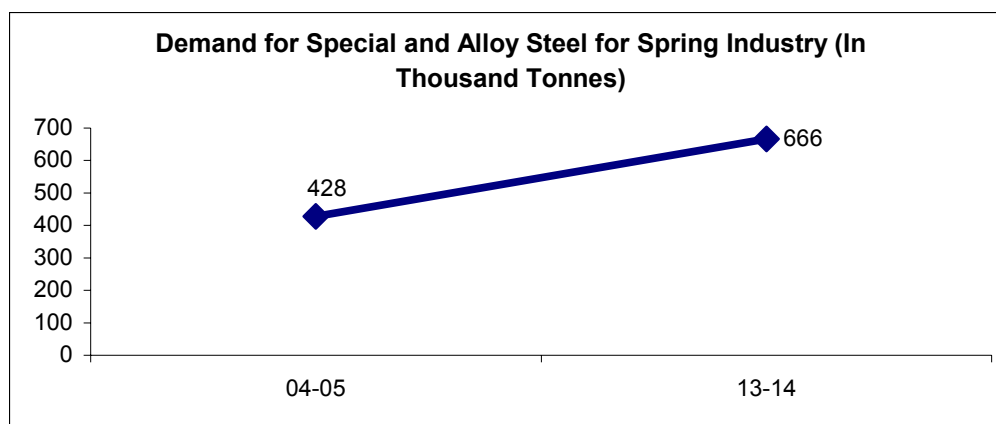

Source: Industrial Development Services Pvt Ltd, New Delhi, Market Survey Report, December 2005

### iii) Bright Bar Industries

Bright bars are cold drawn, peeled or/and ground. These bars are used for mass production of high precision machined components required for automobiles, auto ancillaries, railways and other miscellaneous industry. Cold processing imparts the bar close tolerances. Due to this there is a considerable demand for bright bars in automobile industry.

The current pattern of consumption of alloy and special steel bright bars by major end-use sector is estimated as follows:

End – Use	Relative Share (%)
Automobiles	30

Auto Ancillaries	30
Industrial Machinery	20
Others	5
Exports	15
Total	100

(source: Industrial Development Services Pvt Ltd, New Delhi, Market Survey Report, December 2005)

The future demand of alloy and special steel for this sector till the year 2013-14 has been estimated as follows:

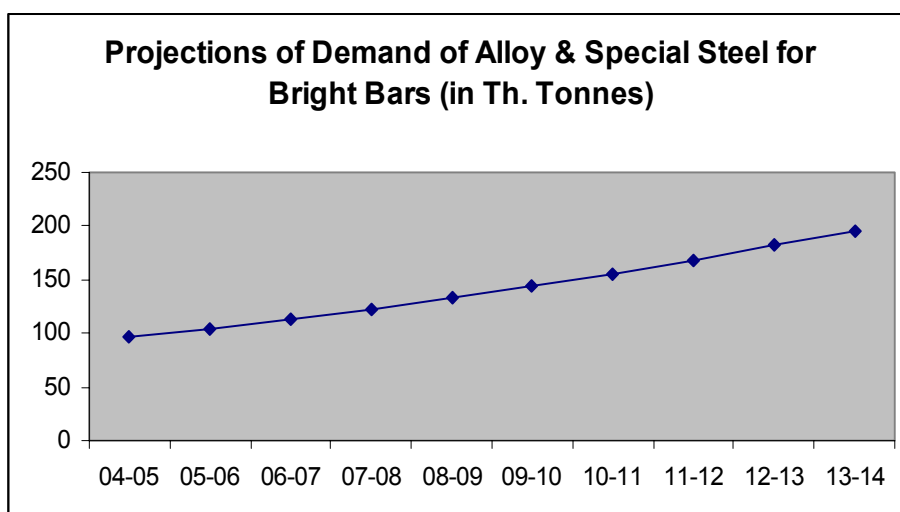

(source: Industrial Development Services Pvt Ltd, New Delhi, Market Survey Report, December 2005)

#### iv) Other Auto Ancillaries

There are over 300 auto ancillaries units in the organized sector engaged in the manufacture of auto components. The main requirement of alloy and special steels by the auto ancillaries industry is for the manufacture of steel forgings and bright bars. Apart from forging and bright bars sectors the followings auto components account for bulk of the direct procurement of alloy and special steels by units under this segment of the industry:

- Piston Pins
- Engine Valves
- Spark Plugs
- Steering Gears

With the rapid growth of automobile industry, the estimated demand of alloy and special steels for auto ancillary industry is estimated as below:

Products	ACGR (%)	
	2004-05 to 2009-10	2009-10 to 2013-14
Piston Pins	6.00	6.00
Engine Valves	10.00	9.00
Spark Plugs	6.00	6.00
Steering Gears	10.00	9.00

(source: Industrial Development Services Pvt Ltd, New Delhi, Market Survey Report, December 2005)

### ***B) Railways***

The demand of alloy and special steels by the railways sector can be split up into three broad areas:

- (a) Billets for Rail Wheel Factory, Bangalore
- (b) Elastic Rail clips
- (c) In addition to the above, spring steel is required for the manufacturer of coil springs used in railway coaches.

The estimated requirements of alloy and special steel for railway sector are expected to increase from about 75, 000 tpa in FY05 to about 107, 000 tpa by FY14 at an average annual growth rate of 4%pa.

### ***C) Defence***

Defence sector is an important consumer of alloy and special steels. In addition to direct procurement of alloy and special steels, defence units also buy some steel forgings from the forging industry. Defence units procure alloy and special steels in various sizes in the form of both square sections, as well as, rolled bars. A growth of 5% in the requirements of alloy and special steels for this sector till the year 2013-14 is expected.

### ***D) Seamless Steel Pipes & Tubes***

Use of seamless pipes and tubes, is split up into two sectors, one oil sector and another non oil sector. In the oil sector, seamless pipes are required for line pipes, casing pipes, production tubing and drill pipes etc. In the non oil sector, seamless steel pipes and tubes are required by a number of priority industries like boilers, ball bearings, automobiles, chemicals plants like fertilizers, petrochemicals, industrial machinery, general engineering etc. There is currently, one Company in the private sector and three major companies in the private sector engaged in the manufacturing of seamless pipes and tubes with an aggregate capacity of 540 thousand tones per annum. The industry currently exports significant share of their production to other countries. At the same time, there are significant imports of seamless pipes, mainly by ONGC. Currently ISMT (Indian Seamless Metal Tubes Ltd.) and Maharashtra Seamless are the largest manufactures of seamless steel pipes in the country, accounting a consumption of almost 12,000 tones per month of alloy and special steels each.

The main growth drivers for this industry are:

- Future outlook for the oil and gas sector.
- Development of export markets by the existing units.
- Pattern of growth for the engineering industry.
- Production program of existing units.

The industry is likely to grow at an average of 10 percent per annum till the year 2008-09.

### **The Market for Auto Grade Special Steel**

The demand-supply equation of the auto grade specialty steel (which some years ago was in favour of supply) has been showing a bias towards demand.

### India- Capacity, Supply & Consumption

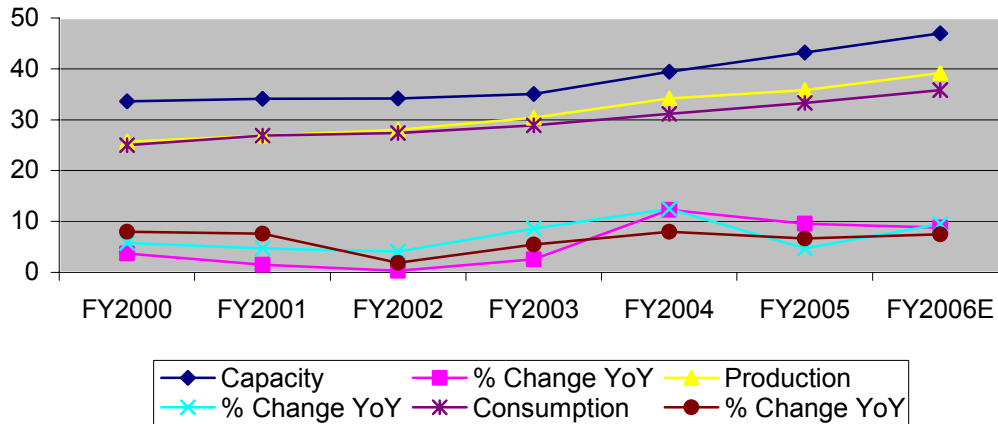

(source: Industrial Development Services Pvt Ltd, New Delhi, Market Survey Report, December 2005)

This has been primarily on account of the significant growth recorded by the auto and auto components industry thereby pushing up the demand for auto grade specialty steel. The average capacity utilisation across the industry has also increased as a result of the shutdowns resulting from the lackluster demand in the initial years.

As per estimates from SIAM, the auto industry is expected to register a growth rate of 8-10% in the coming two years while the auto ancillary industry is projected to clock over 20% growth over the same period. Going forward, the demand outlook appears bright especially considering the fact that India is gradually on its way to becoming the hub for manufacturing auto components.

The Graph below sets out the demand-supply scenario for alloy and special steels in India from FY05 to FY14:

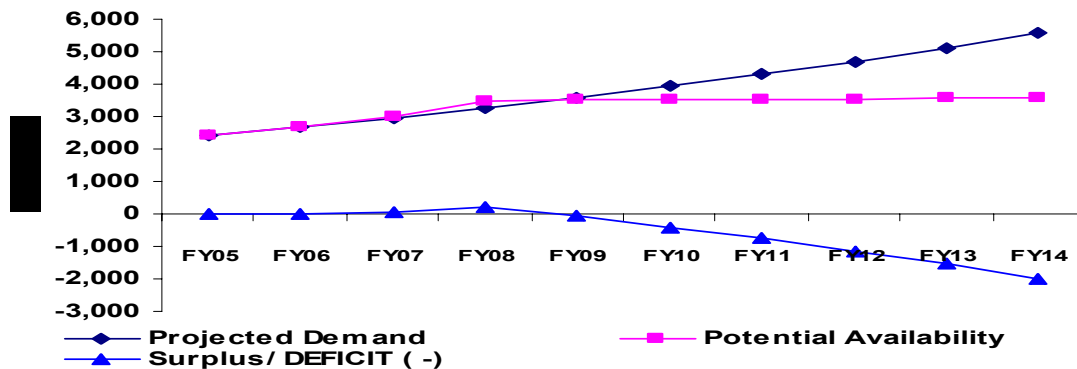

Source: Market Survey Report (December 2005), IDSPL, New Delhi

As can be seen for the Graph above, the availability of alloy and special steels in the country is likely to be adequate to meet the emerging demand till the year FY08 only. The gap in the domestic availability is almost 1.6 million tones by the year 2013-14 offer a good scope for a new entrant to enter this industry.

Domestic availability is likely to fall short of the market demand from 2008-09 onwards. The gap in the domestic availability is projected to increase to almost 1.6 million tones per annum by the year 2013-14. There is also huge potential for export of steel for auto components globally. Indian share in global auto component market is growing at an exponential rate

### Pricing and Margins

According to Industrial Development Services Pvt Ltd estimates, the availability of alloy and special steels in India is likely to fall short of requirements from 2008-09 onwards, though more or less balanced as of now. However India has imported a sizeable quantity of special and alloy steel in last few years. The gap in domestic availability is likely to increase to almost 1.6 – 2.0 million tonnes per annum by 2013-14.

Iron ore-based units are accounting for an increasing share of the domestic production of alloy steels in India during the past few years. The average cost at liquid metal stage in the case of iron ore-based units is Rs 10,000 to Rs 14,000 per tonne as against Rs 17,000 to Rs 18,000 per tonne in the case of scrap-based units. Iron ore-based units thus have more flexibility in meeting the possible threat from imports.

While AML's competitors will have to contend with rising raw material prices and input costs, AML will be relatively insulated from the market volatilities in iron ore, coal and power on account of its integrated nature of operations. This will work to the advantage of AML vis-à-vis its competitors.

## THE STAINLESS STEEL INDUSTRY

### Stainless Steel – the product

Stainless steel is a value added engineering product with high corrosion resistant properties primarily due to the presence of a minimum of 10.5% chromium. This chromium combined with oxygen forms a chrome-oxide surface layer that prevents further oxidation, which results in staining or rusting of a surface. Higher levels of chromium and additions of other alloy elements such as nickel and molybdenum enhance this surface layer and improve the corrosion resistance of the stainless material. Stainless steel today has varied end-uses in production of utensils, household wares, automobiles, architecture, building, construction, surgical equipment, razor blades and coin blanks, industrial applications, railway wagons.

Currently, there are primarily three distinct grades of stainless steel that are produced in the world, comprising the 200 series, the 300 series and the 400 series. The following table sets forth the chemical composition, physical and material characteristics and end use for each of these different series of stainless steel.

SERIES	200	300	400
<b>CHEMICAL COMPOSITION</b>			
Manganese	5.5 % to 12%	2% maximum	1% maximum
Nickel	1% to 4%	6% to 22%	2% maximum
Chromium	10.50 % to 20%	15 % to 25%	[10%] to 30%
Iron	Rest	Rest	Rest
<b>KEY END USES</b>	Utensils and Household ware, Kitchenware/sinks, Tubes and pipes, Architecture/decorative Automobiles/railways/ transport/furniture	Refineries, Petrochemicals, Nuclear applications, Railway coaches, Automobiles, Potable water tubing, Power plants	Razor blade, Exhaust system for automobiles, Tower packing for petrochemicals, Coinage, Railway coaches and wagons, Consumer durables

Source: Indian Stainless Steel Development Association (ISSDA), July 2005

Historically, the 300 series has experienced the maximum demand globally except in a few countries like India, where the 200 series has been popular since the late 1980s, and recently in China, where it has experienced increased demand. Although, the 200 series was originally produced in the U.S. during the First World War, it was primarily developed in India in the late 1980s due to high nickel prices, combined with availability of domestic reserves of chrome ore and manganese.

### ***Applications of Stainless Steel***

The most common everyday use of stainless steel is in cutlery. Cutlery items of a very large variety and range are made out of stainless steel.

Large amounts of stainless steel are used in food production and storage. The most commonly used grades are 304 and 316. Typical uses would be dairies, milk storage, ham curing, frozen and salted fish storage.

The pumping and containment of oils, gases and acids has created a large market for stainless tanks, pipes, pumps and valves. The storage of dilute nitric acid was one of the first major applications of stainless steel in this sector. Special grades of stainless have been developed to have greater corrosion resistance. These are used in desalination plants, sewage plants, offshore oil rigs, harbour supports and ships propellers.

Architecture is also a growing market. Many modern buildings use stainless for cladding. The low maintenance cost and anti-vandal characteristics of stainless provides a growing market in public transport, ticket machines and street furniture.

The nuclear power industry also uses large quantities of stainless, often specified with a low cobalt content, for both power generation and radiation containment. Special louvered ventilation shafts are made, which are designed to be used in emergencies to seal off plants for years if necessary. Steam and gas turbines use stainless because of its corrosion resisting and heat resisting qualities.

Especially clean melted stainless is used for medical implants and artificial hips. A great deal of medical equipment - such as orthopedic beds, cabinets and examination machines - is made as standard from stainless because of its hygienic and easy-clean qualities. Pharmaceutical companies use stainless for pill funnels and hoppers and for piping creams and solutions.

The automotive sector is another major user of stainless steel. Cars are making increasing use of stainless steel, primarily for exhaust systems (grade 409) and catalytic converters, but also for structural purposes.

### ***Stainless Steel Industry Worldwide***

The world SS melting production in 2004 (ISSF) grew at above the historical trend rate of 6% p.a. to reach 24.58 million tonne. Asia is the largest SS producing region in the world with 70% growth occurring there. The total Asian production has grown by almost 12% to 11.9 million tonne. Among all steel categories, Stainless Steel today has the maximum growth potential. There are new applicants borne by SS almost every day and will continue to grow. The world production of SS has grown at CAGR of 6% p.a. over the past many years.

Among the leading metallic materials, stainless steel has registered the highest CAGR between 1980 and 2004 as depicted in the following chart:-

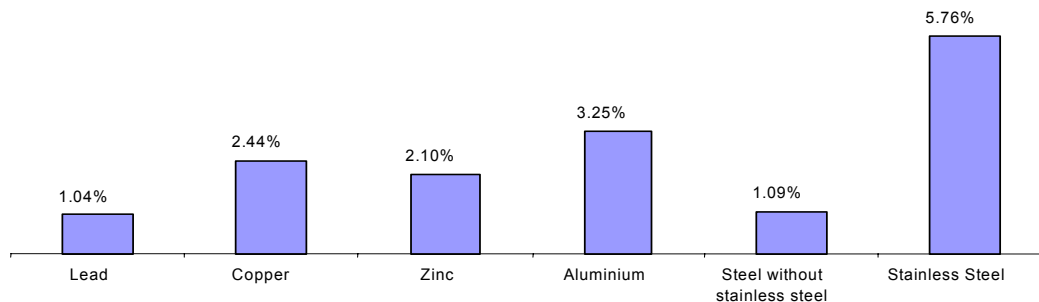

**Source: International Stainless Steel Federation (ISSF)**

During 2006, ISSF expects the underlying demand for stainless steel products to rise by around 5%. However, this may depend on the prices for raw materials. If prices increase further, demand may be affected. ISSF expects that stocks of stainless steel at stockholders and fabricators will be low by the end of 2005. ISSF forecasts that stainless steel production will increase by around 6% during 2006 to re-fill stocks wherever necessary. Total global production in 2006 is expected to be around 26.5 million metric tones for the year.

**Forecast of 2006 stainless steel production (in ‘000 metric tones)**

Region	2004	2005 (p)	+/- (%)	2006 (e)	+/- (%)
Western Europe/Africa	9,422	9,000	-4.5	9,500	5.6
Central & Eastern Europe	312	240	-23.1	280	16.7
The Americas	2,933	2,860	-2.5	2,950	3.1
Asia	11,897	12,900	8.4	13,750	6.6
<b>Total World</b>	<b>24,564</b>	<b>25,000</b>	<b>1.8</b>	<b>26,480</b>	<b>5.9</b>

Source: ISSF

Asia, driven by China and India, is expected to take the lead in stainless steel production in the world.

**Stainless Steel Industry in India**

India has outpaced the global growth rates consistently over last several years against world’s average growth rate of 6%, the Indian production has grown over 16% during last 15 years. India with an apparent consumption of 1.2 million tonnes is placed 7<sup>th</sup> in terms of global stainless steel consumption. The growth rate of consumption of stainless steel in India has been at 10-11% over the last decade. Indian per capita consumption of stainless steel is at 1.1 kg which is far lower than China (4.1 kg) and the developed countries (15-20 kg).

One of the most striking feature of Indian Stainless Steel manufacturing is the production of Cr-Mn series SS. With the huge deposits of chromite ore and manganese ore in the country there is scope for new entrants and to meet the increased demand of various sectors.

The growth in the production of SS in last few years is shown below:

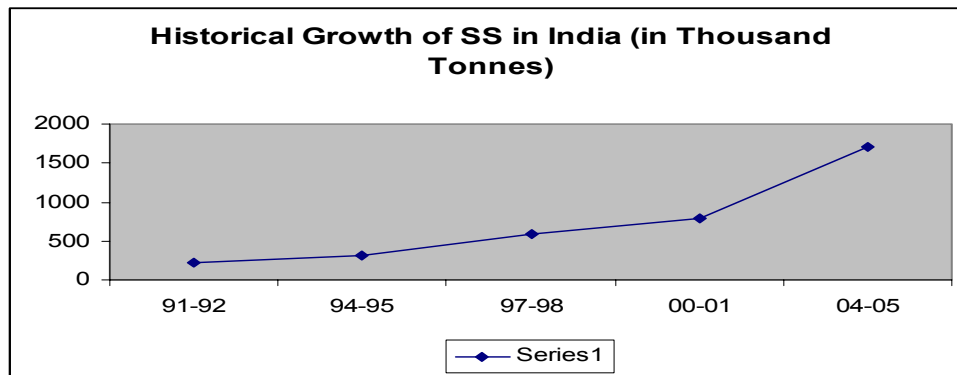

*Source: JPC Bulletin, October'2004 and primary survey*

India has registered an impressive growth rate of 16.2% p.a. in production in the nineties. In the last four years the growth in production has really taken off at 20% p.a.

Approximately 75% of the stainless steel consumption in India is accounted for by the white goods and household goods sector.

The major end users industry / segment of Stainless Steel in the country are following categories:

- Utensils / kitchenware manufactures
- Process Industry (such as Food and Beverage, Textiles, Fertilizers, Paper, Sugar etc.)
- Refineries & Petrochemicals
- Thermal Power Sector
- Engineering Industry
- Fasteners
- Architectural, Building and Construction
- Auto Sector
- Railways

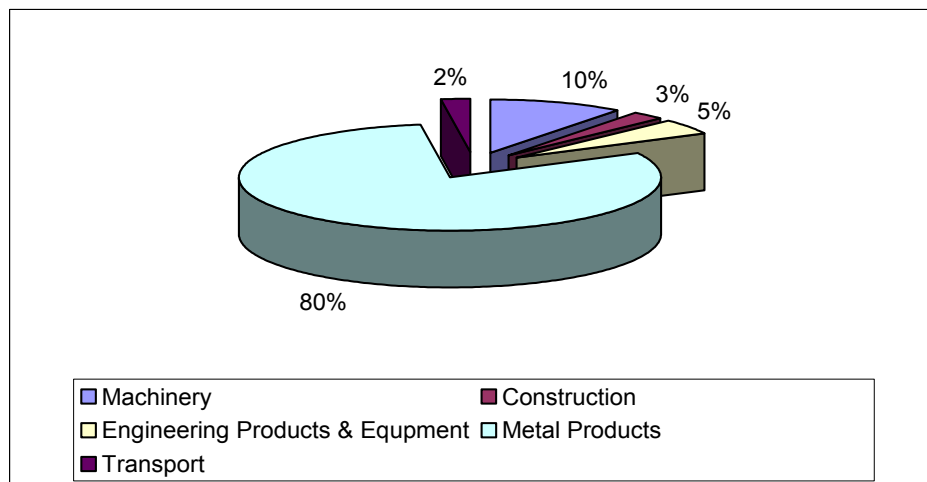

*(Source: ISSMR)*

*(Machinery covers Refinery, Cement, Textiles, Papers, Sugar etc; Engineering Products and equipments covers Cooling Towers, Forgings, Wire Products, Engine, Valve etc.; Transport covers Automobile and Railway Industry; Metal Products covers Utensils, Kitchen wares, Life style products, Cutlery etc.)*

### The category wise growth prospect Stainless Steel

#### *Process Industry*

In the process industry like textiles, fertilizers, food and beverages, drugs and pharma, cement, power, sugar etc. the demand of SS in process industry is emanating both from the new green field projects and replacements/expansion of existing projects. The demand from process industry is set to increase at faster rate in future due to huge amount of investments in major expansion/modernization of various industries. The future growth of SS industry from process industry seems very bright in lieu of anticipated high investment in infrastructure projects and down stream industries which will lead to demand for the basic products produced by process industry. The expected SS demand from process industry will increase at average of 15% p.a. over the next decade which is shown as below.

**Projected Consumption of SS from Process Industry (in Tonnes)**

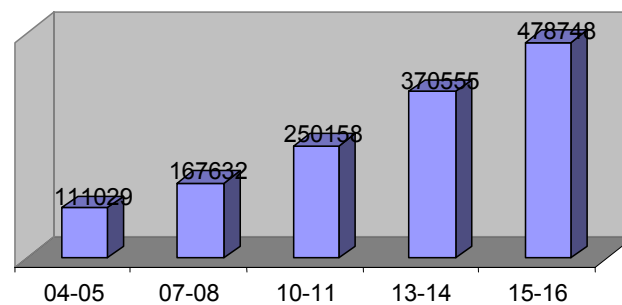

*Source: ISSMR'2005*

#### *Metal Sector*

Metal goods encompass a large number of different products including utensils, kitchen wares, cutlery, commercial kitchen equipments, life style products and various others. This is the largest consumption sector of Stainless Steel in the country. Utensil by far is the largest segment in this category accounting for around 92% share of this segment. The requirement of SS for utensils has grown in the region of 6.5-7% per annum in the past. The growth of this segment is function of the per capita increase in the household income as well as the new house hold in the country. It is estimated that future growth will be at the rate of 7.5% CAGR. The growth path is shown below:

## Projected Consumption of Stainless Steel in Metal Goods Sector

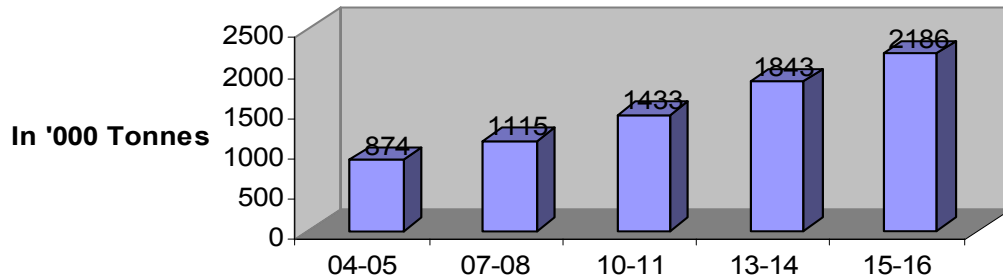

Source: ISSMR'2005

### *Refineries & Petrochemicals*

Refineries consume stainless steel both in the form of new plant and machineries as well as for maintenance requirements. Almost 7.5% of the total machinery cost in the oil and refinery segment is comprised of stainless steel fabricated items and components. The consumption is expected to increase at a growth rate of around 14% per annum. Almost 90% consumption in this sector is for 300 series SS.

Petrochemical is another large consuming segment for Stainless Steel in various forms for application similar to as covered under refineries.

### *Thermal Power Sector*

In thermal power plants there is a considerable usage of SS in turbines, flue gas desulfurisers, pollution control systems, boilers etc. Due the current power shortage in our country, the Government plans to add 150,000 MW of generation capacity over the next decades to bridge the current demand supply gap. The power generation has to grow by 9-10% per annum if India has to achieve a consistent 7% GDP growth. The growth of SS in this sector is anticipated to grow at 14-15% per annum during next decade.

### *Engineering*

Engineering is a diverse industry with a number of segments. Engineering industry is also a large consumer of Stainless Steel. The major products consuming SS in this category include pumps, valves, boilers, environmental control equipments, forging, furnaces, cooling towers etc. The growth prospects of this segment are very bright due to growth prospectus not only in the domestic markets but also in international markets. The growth of SS in this sector is anticipated to grow at 15-16% per annum during next decade.

### *Fasteners*

The major areas of consumption of fasteners are Automobiles, Engineering, Telecom, Electrical appliances and Construction. The future expected growth of fasteners is estimated at 20% p.a. The main growth areas would be Automobiles, Telecom and Construction which is expected to grow between 25 to 30% p.a. The future expected market of SS in this segment by 2009-10 and 1015-16 is estimated at 23,000 and 71,000 tonnes respectively.

### *Auto Sector*

The automobile sector is expected to boom in India. The consumption of SS in this sector is very potential. Internationally in the developed countries it is the single largest segment for SS consumption. SS is used for variety of automobile components by virtue of its excellent corrosion resistance, heat resistance and good appearance. The auto industry encompasses commercial vehicles, multi-utility vehicles, passenger

cars, two wheelers, three wheelers, tractors and auto components. One of the striking features of the auto components industry is its exports which have been recording healthy growth rates. On account of its low cost technical manpower and ever increasing focus on quality, the Indian auto industry has emerged as an export hub, especially for compact of car segment. The exports of passengers car from the country has increased at a healthy CAGR of nearly 38% during the past five years and increasingly more and more global auto majors are lining up to set up their production bases in the country. Auto parts industry has also emerged as one of the fastest growing manufacturing sector of the country.

### ***Railways***

This sector is also has huge growth potential for SS. The SS will be consumed by this sector for manufacturing of railway coaches and wagons for transportation in addition to coaches for metro. The expected growth of SS from railways and metro sector will in the region of 15 to 17% p.a.

### ***The Outlook***

India's consumption of Stainless Steel is increasing gradually but the per capita consumption is still as low as 1.1 kg as compared to 15-20 kg in the western world. The major factors that hold back increase in the consumption of stainless steel in India are a lack of awareness about its use and benefits, non-availability of skilled fabricators, under developed production technology etc. as reasons for such low consumption.

India's consumption of Stainless Steel is on the upswing but the per capita consumption is still as low as 700 grams as compared to 14/15 kgs in the western world. ISSDA found a lack of awareness about its use and benefits, non-availability of skilled fabricators, under developed production technology etc. as reasons for such low consumption. However, with the improvement in the lifestyle of the average Indian and the burgeoning middle class with a higher propensity to spend on lifestyle products, the per capita consumption of stainless steel in India is expected to improve significantly.

Besides, ISSDA's efforts to help increase the consumption of stainless steel in the country are already showing some positive results. The future of the Indian Stainless Steel industry is bright and favorable government policies will help its further growth.

However, improvements in the lifestyles of the average Indian and overall economic growth in the country have provided significant fillip to the stainless steel sector in India. The future of the Indian Stainless Steel industry is bright and favorable government policies will help its further growth. Among the various factors, the most important one driving the overall SS consumption as expected is GDP or the per capita income. The volume of stainless demand in India is projected at 1.69 million tonnes for 2006-07. [Source: <http://ipcindiansteel.org>] Approximately 70% of the stainless steel demand will be in the 200 series for the utensil sector while the balance 30% will be for the 304 and 316 grades for the industrial sector.

The projected growth in the 200 series Stainless Steel segment (*which will be one of the focus areas of AML's product portfolio*) has been depicted in the following chart:-

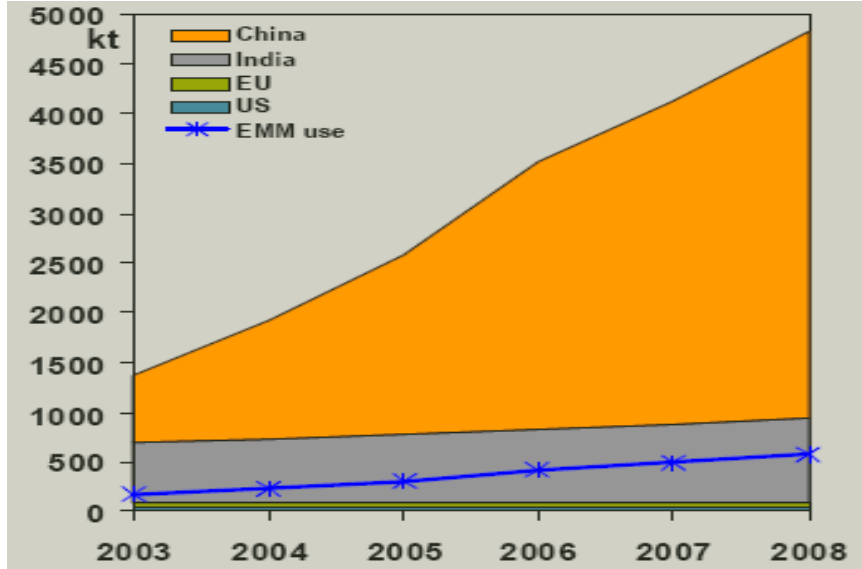

*Source: Metal Bulletin – 6<sup>th</sup> Asian Ferro Alloys Conference (Hong Kong)*

### ***Stainless Steel Prices & Margins***

In April 2005, international prices of stainless steel remained stable, driven by stable nickel prices and in the domestic market, stainless steel prices remained stable as well, except for a marginal decline experienced in export prices of stainless steel HR flats. Export prices declined because of lower demand from China, because of inventory build-up. In May 2005, international prices declined marginally on the back of low demand. However, domestic prices rose slightly on the back of high demand. Weak demand for stainless steel in the international market is likely to exert downward pressure on international stainless steel prices. However, as per Cris Infac, domestic prices are likely to remain stable due to steady demand.

## **OUR BUSINESS**

## BUSINESS OVERVIEW

Our Company belongs to the Adhunik Group promoted by the Kolkata based Agarwal family. Adhunik group is operating in the Iron & Steel and Ferro-Alloys industry with a presence largely in Eastern India. Our promoters have been associated with the steel industry for three decades and have in-depth knowledge of the iron & steel market. The group has various activities like manufacturing, processing, trading of iron & steel scrap, and secondary as well as primary products and has set up manufacturing facilities in the States of West Bengal, Orissa, Jharkhand and Meghalaya (all in Eastern India). The product portfolio of the Adhunik group presently comprises a range of value added products including high quality Sponge Iron, Pig Iron, High Carbon / Low Carbon & Alloy Billets, Ferro Alloys, Rounds and Flats, TMT Bars, High Carbon/ Low Carbon Wire Rods, Ferro Manganese, Silico Manganese & Ferro Silicon, and MS & GI Pipes.

Our Company was incorporated in the year 2001 with an aim of manufacturing value added steel products having application in automotive industry, engineering sector as well as the household sector. We started our operations in the year 2003 and the existing plant has been set up in a phased manner. Operations in Unit I in the year 2003 and Unit II was commissioned in the year 2005. We are also in the process of setting up a captive power plant under Unit II. The plant is also equipped with a coal washery. We presently have manufacturing facilities for 2,50,000 tons per annum of carbon and alloy steel billets. The current production facilities of the Company are suitably integrated with sponge iron and pig iron making facilities. Our products presently include Sponge Iron, Pig Iron and Alloy Billets. Further, the Company has initiated rolling of its billets through third party arrangements to meet the current requirement of rolled products in various segments.

Our products adhere to high quality standards and our operations are ISO 9001 certified. This ensures that our products are consistently within the specification parameters .

The Company is in the process of implementing a project for enhancing the production capacities and exploiting the inherent synergies within the current value chain and operate as an end-to-end manufacturer of special/alloy steel, mainly of auto grade, engineering grade as well as stainless steel. The Rs. 437 crore project will fully integrate the Company over the entire value chain, i.e. the process will start from the raw material i.e. iron ore/coal to value added finished specialty steel and alloy steel for automotive, engineering and forging applications. The product mix of the Company would also comprise stainless steel for use in the production of utensils, automotive ancillaries and various process industries. The other major objective of the expansion is to gainfully utilize waste/rejected materials generated in the manufacturing process in the plant. This would ensure usage of blast furnace gas, waste heat/char from DRI and middling from coal washery as fuel, iron ore/coke fines as input raw material to blast furnace in form of sinter.

### **Phase I of the Project (Unit I and Unit II mentioned above which have already been implemented)**

The Company is having an integrated facility to produce various grades of carbon and alloy steel billets. The present project was implemented in a phase-wise manner. The detailed feasibility report of this project was carried out by MECON Ltd. However, for consultancy and detailed engineering of various facilities the Company has appointed reputed consultants from respective fields. The present facilities are further bifurcated into two parts viz. Unit I and Unit II. Unit I comprises coal washery and sponge iron and Unit II is defined as steel division.

The project has been put in a phased manner so that each unit is treated as an independent profit center and with their implementation they start generating profits for the business as well as future projects and also help in debt servicing.

The various facilities of the Unit I and Unit II have been summarized as under:-

<b>Module</b>	<b>Rationale</b>	<b>Installed Capacity</b>	<b>Detailed Engineering &amp; Consultancy</b>
<b>Coal Washery</b>	For washing of coal to be consumed by DRI Kilns.	700,000 TPA	Aker Kvaerner, U.K.
<b>DRI Division (100 TPD x 5 Kilns)</b>	For manufacturing of Sponge Iron to meet the captive requirement of metaliks.	150,000 TPA	Popury Engineering
<b>Blast Furnace (1 x 262 CuM)</b>	For manufacturing of Pig Iron. After commencement of Steel Melting Shop (SMS) major quantity of hot metal will be consumed captively.	180,000 TPA	MECON Ltd., Ranchi
<b>Steel Melting Shop consisting of 35 Ton EAF, LRF, Continuous Casting Machine &amp; Captive Oxygen Plant</b>	For manufacturing of Special and Alloy Steel to meet the market demand of Automobiles, Engineering, Locomotive sectors.	250,000 TPA	R. Singh & Associates, Nagpur
<b>Captive Power Plant (12 MW)</b> (Expected to be commissioned by first quarter of 06-07)	To meet the captive power requirement and use the waste heat gas generating from DRI Kilns.	73.44 Million Units p.a.	Avant – Garde Engineering & Consultants (P) Limited, Chennai

### **Phase II - Unit III**

We are in the process of expanding our present steel manufacturing capabilities by way of backward and forward integration. The upcoming expansion will fully integrate the Company over the entire value chain, i.e. the process will start from the raw material i.e. iron ore/coal to value added finished specialty steel and alloy steel for automotive, engineering and forging applications. The product mix of the Company would also comprise stainless steel. The other major objective of the expansion is to gainfully utilize waste/rejected materials generated in the manufacturing process in the plant. This would ensure usage of blast furnace gas, waste heat/char from DRI and middling from coal washery as fuel, iron ore/coke fines as input raw material to blast furnace in form of sinter. Therefore, the Company can generally be classified as a supplier of raw material to the OEMs (Original Equipment Manufactures) in the automotive segment and engineering segment as well as to users of stainless steel for household and industrial/engineering purpose. The envisaged product mix is depicted in the following chart:-

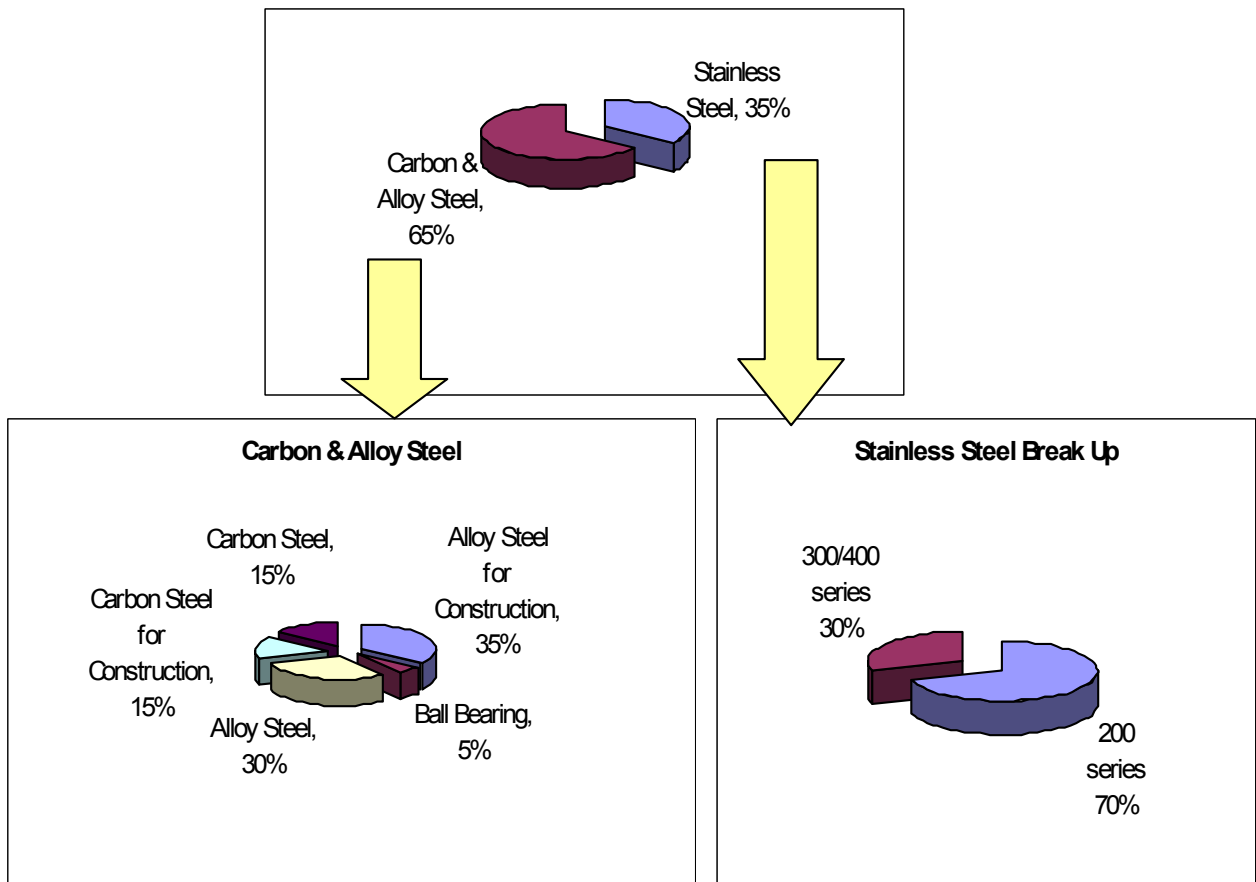

## MANUFACTURING LOCATIONS

### Existing plants:

The Company's existing manufacturing operations are located at Rourkela, Dist. Sundergarh, Orissa.

### Proposed plants:

The proposed projects are also to be set up at the existing site at Rourkela, Dist. Sundergarh, Orissa.

## MACHINERY, TECHNOLOGY AND PROCESS

### Unit I

Presently AML is operating five DRI (sponge iron) units of 100 tpd capacity each in the Sponge Iron Division at Sundergarh, Orissa.

### Unit II

The Company has a billet casting plant of 2,50,000 MTs per annum of carbon and alloy steel billets. The capacities of other facilities in the unit II are as under.

- 1 (one) no. 262 Cubic meters per day capacity Mini Blast Furnace (MBF) along with the auxiliary & balancing facilities.

- 1 (one) no. 35 M.T. batch capacity Electric Arc furnace, with adequate capacity of Transformer and breaker and all other auxiliary & balancing facilities.
- 1 (one) no. 6/11 M radius 2-strand continuous casting machine to cast billets of sizes ranging from 100 mm sq. to 200 mm sq.
- 2 x 400 SM<sup>3</sup> Oxygen Plant
- 12MW Captive Power Plant (CPP) as Cogeneration to DRI Units

All the above facilities except Captive Power Plant (CPP) have already started the operation recently in phased manner. The Captive Power Plant is expected to commence operations by April 2006. Additionally, it has a coal washery.

### Unit III: Proposed Expansion

The management of AML has decided to further add the following facilities in the plant for various associated benefits as given in the following table:

Sr. No.	Facility	Installed Capacity	Rationale
1.	2 <sup>nd</sup> SMS with Vacuum Degassing (VD) Plant	1,56,300 MTpa	To meet the increased requirement of Crude Steel, 2nd SMS is being set up. It would also enable AML to utilize all the metaliks captively. Processing in VD would produce high quality cleaner alloy steel billets/blooms.
2.	Rolling Mill	2,20,000 MTpa	For rolling of Carbon & Alloy Steel Products and Stainless Steel Products.
3.	Argon Oxygen Decarburization Plant with Bloom CCM	1,19,000 MTpa	For production of Stainless Steel.
4.	Ferro Alloy Division	33,760 MTpa	The Ferro chrome produced would be captively consumed in the production of Stainless Steel. Hot Ferro chrome would be charged to AOD, which would result in electricity cost savings.
5.	2 <sup>nd</sup> Captive Power Plant	18 MW	For cogeneration of power to meet the increased requirements of the plant.
6.	Sinter Plant	96,000 MTpa	By use of Sinter in blast furnace, fuel rate is expected to come down while productivity as well as quality of hot metal is expected to improve. Besides this all wastes and fines will be captively consumed and hence waste will be managed efficiently.
7.	Oxygen Plant	97,92,000 SM <sup>3</sup> pa	For captive consumption in steel making. The self-generated cost of oxygen is very low in comparison to the purchase cost of oxygen.
8.	Private Railway Siding	-	For economical, efficient and timely transportation of raw materials and finished goods.
9.	Captive Iron Ore & Coal Mining	-	To meet the iron ore & coal requirement of the plant, which will drastically bring down the ore cost and ensure smooth and steady supply of the same.

**a) Existing Operations: Unit I & Unit II**

The various machinery at the existing facilities of the Company are:

UNIT – I	UNIT - II
	Blast Furnace Proper
Vibrating Screen for Coal	MBF Proper Shell
Complete Kiln & cooler Assly	Stove Shell
Refractories	Dust Catcher shell
Central Burner Pipe	Waste gas main and chimney
Self Priming Centrifugal Pump	Hot blast main
ABC Pump	Bustle main
Kiln Slip Rings ( Stationary + Rotary ) Segemnts	Dome for H/B Stove
Kiln Auxiliary Gear Box	Top Charging Equipment alongwith pneumatic cylinder
Cooler Main Gear Box	Stock level indicator system
Air Receiver Tank with all accessories	Tuyeres (Copper) & Coolers
Lubrication System	Tuyeres stock assesmbly
Permanent Magnetic Concentrator Separator	50 MT Laddle Weigh Bridge
Hydraulic Jack, Quick Coupler, Speed hand Pump	60 MT Road Weighbridge
Forced Draft Cooler	Pig Casting Machine
Vibrating Screen for Product	BF Gas Cleaning Plant
Automatic Weighing & Bagging Machine	Effluent Treatment Plant of GCP
Conveyor Equipments	Ignition System - BF Gas Flare Stack
Geared Motors	Compensator For Hot Blast Main & Dust Catcher
LDO Oil (KL)	Air Blast fan including blowers (excluding motor)
LDO Oil Tank	30T/35T EAF With EBT System With all Accessories
Support Insulator Heater	30T/35T Laddle Furnace With all Accessories
D.G.Set	Raw Material Handling System
Instrumentation	Conductors, Insulators & Accessories
PLC Driver & Automation System	MCC and PDB System for Plant
Motors for Equipments and conveyors	PLC for MBF
	PLC for EAF
	PLC for LRF
	PLC for Continuous Caster
	PLC for FES
	PLC for Pump House
	Programming & Soft Ware
	Drive System
	Instrumentation for Plant
	Oxygen / Nitrogen Line for EAF
	Transformer
	HT Distribution Board
	132 KV Sub-Station
	DG Sets
	Make up Water Treatment Plant
	Cooling Tower
	SMS Water Pump
	Package Boiler
	Plate Heat Exchangers
	Compressor House (Pr.Vessel/Drier)
	Fire fighting Equipment
	High Pressure Bolier

	Steam Turbine With Accessories
	D. M. Water Plant With All Accessories
	Pollution Control Equipments
	PLC& DCS System
	Bag House & ID Fan
	ID Fan Motor
	Dust Handling System
	Cumbustion Chamber
	Stock House Dust Extraction System
	Electro Magnetic Stirrer
	Cranes
	Turndish Car
	Tundish Prepration Stand
	Oxygen Management System
	Laddles - MBF
	Drive System
	UPS system
	Electrode Regulation System
	MCC Panel
	Pyrometers
	Copper Delta for EAF
	LDO Station
	Spectrometer
	Sample Cutting machine

### **MANUFACTURING PROCESS**

The choice of the technology was based on the merits and demerits of various technologies, the status of technology, flexibility of operation, availability of raw materials, capital investment and economics of operations. The DRI – MBF – EAF – LRF – VD / AOD – CCM – RM route is considered for the integrated plant. The proposed detailed manufacturing process for the integrated steel plant is given below.

### **The Process Flow Chart**

The following schematic represents the process flow chart of the overall operations of the Company, subsequent to the implementation of Phase II (Unit III):-

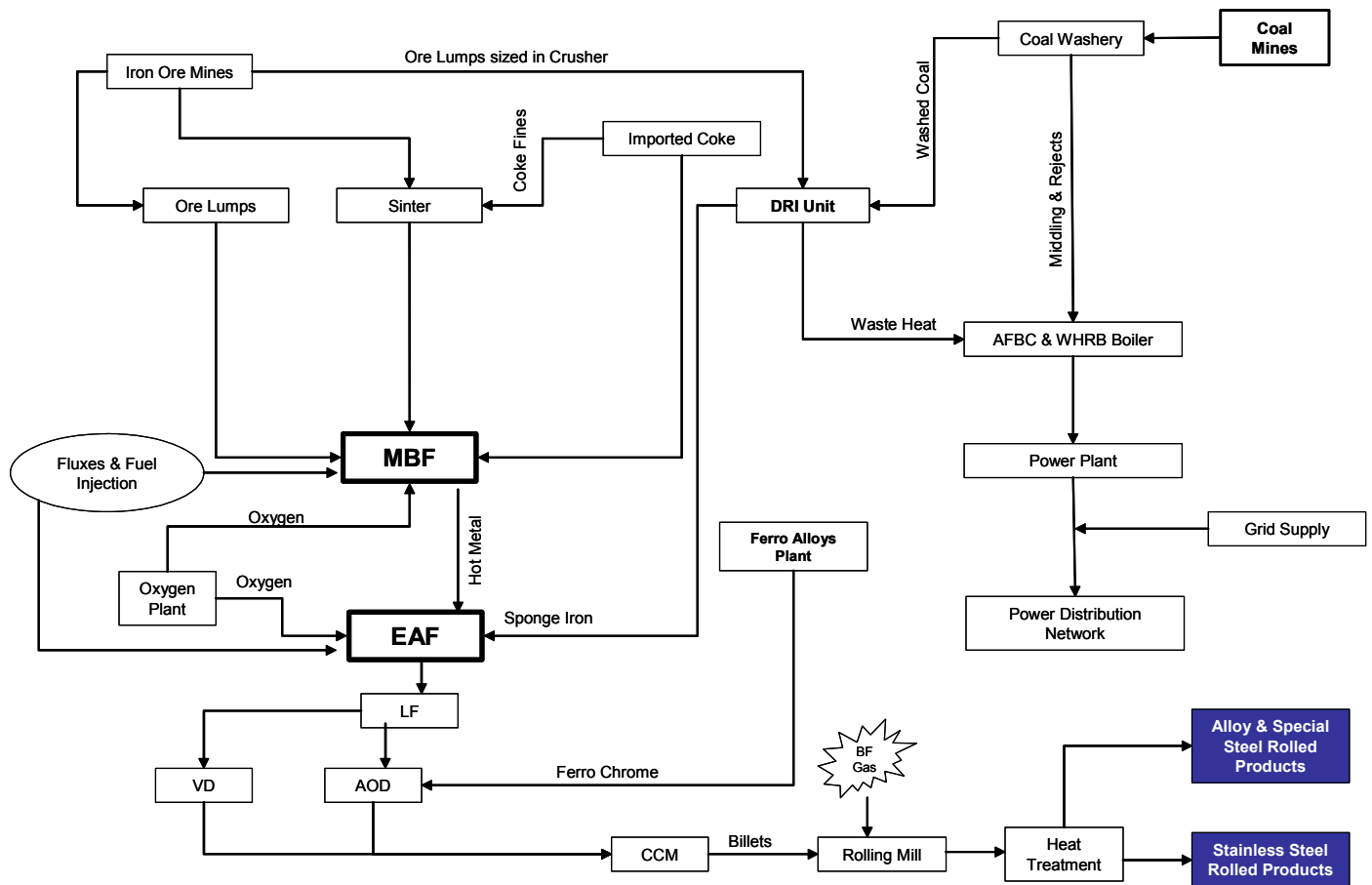

## Iron Making

### Rotary Kiln process for DRI

In this process a refractory lined Rotary Kiln is used for reduction of iron ore in solid state. The kiln is mounted with a slope of 2.5% downwards from the feed end to the discharge end. A central burner located at the discharge end is used for initial heating of the kiln.

In the kiln, the iron ore is dried and heated to the reduction temperature of 1000°-1050°C. The iron oxide of the ore gets reduced to metallic iron by carbon monoxide generated in the kiln from coal. The heat required for the reduction process is supplied by the combustion of coal.

Thermocouples are installed along the length of the kiln shell for measurement of thermal profile of the kiln. The temperature is controlled by regulating the amount of combustion air admitted into the kiln through several ports with the help of fans mounted on the kiln shell and by controlled coal slinging. The DC main drives provided to rotate the kiln have variable speed. Auxiliary drive is provided for flow rotation.

The reduced product is discharged into a rotary cooler along with coal ash, calcinated limestone and residual char, where they are cooled to below 100°C indirectly by spraying water on the outer surface of rotary cooler. The product is then screened and magnetically classified.

### *Submerged Arc Furnace for Ferro Chrome*

The smelting is a continuous process and is done at a line voltage of 70-170 V. The mixture is charged into the furnace, mainly onto the electrodes as the preceding portion melts down. The coke should not have high sulphur content. Uniform light yellow flame at the top and easy tapping of alloy and slag and their correct composition are proof of normal operating conditions.

Slag and alloy are tapped into a firebrick-lined ladle/ CI (Cast Iron) moulds simultaneously through the same tap hole, three-four times per shift. Slag is poured from the ladle into sand beds or granulated. After tapping, the tap hole is plugged with clay and electrode carbon paste as deep as possible.

During tapping, a sample is taken and analyzed for Cr, Si, C, P and S contents. The metal from the ladle is further cast into ingots. The cooled ingots are crushed into lumps, cleared from slag and stored.

### *Mini Blast Furnace*

For production of hot metal, the unit has already installed a 262 cum blast furnace. In the blast furnace, the burden of iron ore and coke is reduced into hot metal. Coke is used both as reductant and fuel. The hot metal produced is transferred to Electric Arc Furnace for primary refining or cast in pig casting machine. To maintain heat in the furnace stove has been set up.

### *Processing At Electric Arc Furnace (EAF)*

Hot metal is charged into electric arc furnace and blown by injecting oxygen. Lime is added after the bath temperature rises. On attaining the bath temperature above 1600°C, feeding of DRI is commenced at pre-determined rate with transformer at full load. During continuous charging and smelting of DRI, oxygen is injected for foamy slag operation and de-carburisation of melt. The foamy slag shields the arcs promoting better heat transfer to the bath as well as to arrest radiation to the sidewalls. Lime is charged to maintain the slag basicity. Dolomite is charged to maintain certain level of MgO in slag as well as for slag door maintenance.

As soon as the charge is melted, bath sample is taken and the steel temperature measured. The steel at this stage is ready for tapping. If necessary, the temperature is adjusted and the steel tapped into a pre-heated ladle placed on the ladle transfer car below the furnace tap hole.

Predetermined quantity of Ferro-alloys and de-oxidizers are dosed into the ladle during tapping. After tapping of the furnace, EBT (Eccentric Bottom Trap) is closed, furnace walls and banks are inspected and if necessary gunned/fettled. The furnace is then ready to commence the next melting operation.

### *Secondary Refining at Ladle Furnace (LRF)*

The ladle is lifted from ladle transfer car and placed on ladle stand for LF treatment. The LF roof is swung and placed over the ladle rim. Heating starts by striking the arcs. Inert gas (Argon) is bubbled through a porous plug provided at the ladle bottom throughout the LF treatment. During the treatment, temperature is measured and samples are taken periodically. Lime, Ferro-alloys and fluorspar are weighed and added to adjust the final temperature and analysis. On demand from the caster, the ladle is transported to the caster with the help of EOT crane for casting. Aluminum is added manually for Aluminum-killed steel production. The EAF slag is collected in slag pot placed on the ground floor below the EAF slag door. Filled up slag pots are handled by cranes. Liquid slag is poured into the slag dump from where it is disposed off using pay loaders and dumpers.

### *Vacuum Degassing (VD)*

After placing the ladle in the VD Vessel and sealing the cover, processing starts. Vacuum is achieved by operating different ejectors with the help of super saturated steam. Under vacuum, following “Severt’s Law” the gaseous content in liquid steel decreases depending on to their partial pressure and longevity of treatment. Due to Argon purging under vacuum, the non globular shaped inclusions are arrested to the active basic slag.

### ***Argon-Oxygen Decarburization (AOD)***

In AOD, decarburization process is carried out which is basically done for further refinement of steel through reduction of carbon content. The process is required because the amount of carbon in stainless steel must be lower than that in carbon steel or lower alloy steel (i.e., steel with alloying element content below 5%). While Electric Arc Furnaces (EAF) is the conventional means of melting steel, AOD is an economical supplement for refining the same. In addition, using AOD for refining stainless steel increases the availability of the EAF for melting purposes.

In the process, molten, unrefined steel is transferred from the EAF into a separate vessel. A mixture of Argon and Oxygen is blown from the bottom of the vessel through the melted steel. Cleaning agents are added to the vessel along with these gases to eliminate impurities, while the oxygen combines with carbon in the unrefined steel to reduce the carbon level. The presence of Argon enhances the affinity of Carbon for Oxygen and thus facilitates the removal of Carbon.

### ***Continuous Casting***

The casting ladle after treatment at the ladle furnace / VD / AOD is picked up by the ladle handling crane and placed on the ladle stand of the continuous casting machine. In the mean time a tundish lined with refractory materials, preheated to about 1100 °C and mounted on the tundish car is moved from the reserve position to the casting position. The ladle slide gate is opened to allow flow of liquid steel into the tundish. The liquid steel stream from the ladle to tundish is protected by ceramic tube to avoid oxidation and formation of inclusions in the steel.

Prior to start of casting operation, dummy bars are introduced into the moulds. The gap between dummy bar head and mould walls is sealed with asbestos chord and small pieces of steel scrap are placed over the dummy bar head for chilling of initial liquid steel.

Water supply to moulds, secondary cooling zone and machine cooling is then switched on. When the liquid steel level in the tundish reaches a predetermined level, the nozzles of the tundish are opened for flow of metal into the moulds. The liquid steel stream from tundish to mould is protected by shroud system to ensure superior quality of cast products.

When the liquid steel level in the mould reaches about 100-150 mm from its top, the drives of the mould oscillating mechanisms and withdrawal and straightening units are switched on. The withdrawal of dummy bar begins at the minimum speed and gradually increases to normal casting speed within a few minutes. The lubrication of mould walls is done by adding requisite quantity of mould lubrication oil.

During casting operation, the metal level in mould is maintained within predetermined limits by adjusting the strand withdrawal speed. The liquid steel level in the tundish is also kept within permissible range by adjusting the opening of ladle slide gate.

The partially solidified strand after leaving the mould passes through the strand guide rollers segments where intensive but controlled cooling of the strands is achieved by direct water spray with the help of nozzles. The solidified strand is guided through strand guides, withdrawal and straightening unit before entering in the cutting zone. The dummy bars are separated from the cast strands of billet caster when dummy bars reach beyond the withdrawal and straightening unit and are stored in a dummy bar storage device till their introduction is required for the next cast. The cast strands are cut into predetermined length by automatic oxy-LPG cutting torches. The cut billets / blooms are delivered to cooling bed through run-

out roller tables. Pushers are provided for pushing billets / blooms on the cooling bed where these billets will be marked. The marked billets are lifted by billet handling magnet crane for storage in the billet storage bay.

### ***Rolling Mill***

Blooms from SMS are received in the Bloom Storage Bay and are stacked size-wise as well as grade-wise. These are then inspected for surface defects. Minor defects, particularly for stainless steel, are rectified by grinding.

Depending on the product being rolled, blooms are lifted by the EOT crane and placed on the Charging Gate of the Reheating Furnace. After this, complete operation of the Reheating rolling and cooling of bars is mechanized and automated through stand-alone automation as well as process control from computers.

Well heated and soaked blooms are discharged from the front end of the Reheating Furnace by an Extractor. The bloom then travels toward the Reversing Mill. On the way, Descaling takes place in a Descaler by high pressure water jets. Blooms then enter the Reversing Mill. Depending on the final product, a number of to and fro passes are given at the reversing mill with the help of roller tables, manipulators and turning device. Heavy Rounds & RCS (Round Corner Steel) are finish rolled from the Reversing Mill itself and taken to Hot Saw for cropping and dividing into Cooling Bed Lengths through on line heat treatment solution. Cooled bars are then lifted from the cooling bed cradle by the storage bay EOT crane and taken for inspection or post rolling finishing operations.

For other sizes, bars from Reversing Mill pass through the Intermediate and Finishing Mill strands. Here also, depending on the Rolling Schedule, a number of to and fro passes are taken at the intermediate stands. The finished bars are end cropped and then divided into Cooling bed lengths at Hot Saws. Two Cooling Beds are provided to cope with the high rate of rolling. After cooling, the bars pass through inspection and/or finishing facility section. Finished bars are bundled and stacked grade-wise for easy identification at the time of dispatch.

### **Other Supporting Processes**

#### *Coal Washery*

Coal is an important raw material in an integrated steel plant. Coal and coal products are mainly used in production of sponge iron, pig iron and in captive power plant. Coal is the India's most abundant, safe and secure fossil fuel for use in Steel Plants, Cement plants and Sponge Iron Plants. However, availability of good quality coal is limited in nature. The ingress of extraneous dirt further deteriorates the quality. As a result coal of recommended grade is not available. A dedicated coal washery can only help supply of washed clean coal of recommended quality to the user plants so as to avoid the disadvantages associated with inferior quality of available coal.

Coal Washing is a process by which the Raw Coal is treated to improve its quality, as received from the mines by removing the extraneous dirt and part of intermingled mineral matter, which has been liberated on crushing to a specified size. This is to achieve reduction of ash content in the coal, for use in subsequent processes. It can be done either by Dry De-stoning or Wet washing. In wet washing, coal is first crushed to a optimum pre-determined smaller size, mixed it with a liquid medium of intermediate Specific Gravity and subjecting the Mixture into a Separator to facilitate separation of lighter coal (Low in ash content), known as Clean Coal, from the Heavier Coal (High in ash Content) as Rejects.

A 0.7 Mn TPA coal washery employing Heavy Media Cyclone Process was set up by the group under Adhunik Mineral & Alloys Ltd. To synergize the operations, it has been merged with AML.

#### *Sinter*

It has been well established in large and mini blast furnaces that with the use of sinter, fuel consumption rate can be significantly brought down and simultaneously improvements in productivity and hot metal quality can be achieved. For the proposed sinter feed, productivity is expected to increase by around 5% and coke consumption is expected to decrease significantly.

Apart from the above advantages, almost all the waste materials, flue dust and sludge can be utilized in sintering process, which would minimize waste disposal problem.

The sintering process starts with the preparation of raw mix consisting of iron ore fines, fluxes, plant waste materials, fuel and return fines. Several bins are provided for the storage of each raw material. The abovementioned materials are discharged from the bins in predetermined quantities by means of feeders in weighing bins. The weighing bin discharges the iron ore fines, mix, coke, return fines and plant waste material, into a mixer. After proper mixing, the material is transferred to a micro-palletizing drum where water is added in order to reach proper agglomeration of the raw mix, in the form of micro pellets, and to assist the same in obtaining optimum permeability. The raw mix is conveyed carefully to the feeding bin of the sinter machine. Before the raw mix is fed onto the sinter machine, the pan bottom has to be protected with a layer of “bedding”. The pans are fed by raw mix and then ignited. After feeding, the surface of the raw mix is ignited using gas or oil burners. Air is sucked through the ignited mix layer through the bottom of the pan and sintering proceeds downwards in the material bed. After the process is complete, the sinter is discharged on to stationary grate for breaking and further breaking is accomplished with the help of a crusher. Subsequently, the sinter is cooled down in the open yard, after the sinter is cooled, it is properly screened. Product sinter, bedding and return fines are conveyed to the respective storage bins.

#### *Captive Power Plant*

The basic function of the Captive Power Plant in this unit would be to ensure availability of adequate electrical energy in a cost effective manner utilizing primarily off gases and waste by-products of various modules. The power thus generated will be used for powering the DRI, SMS, Ferro Alloys, Rolling Mill modules and meeting general requirements associated with the production of steel. The station thermal cycle, layout and rating of various Plant and Equipments have been selected accordingly.

The fuels envisaged for power generation are:

- Off gases from DRI kiln “After Burning Chamber” (ABC)
- Blast Furnace gases
- Char produced by sponge iron kilns
- Washery Rejects from Coal Washery

#### 12 MW CPP (WHRB)

For achieving utilization of Waste Gas from existing 5 x 100TPD DRI Plants, the Company is installing 12 MW CPP under Unit II plan, as Cogeneration to Five 100 TPD DRI Units.

#### 18 MW CPP (WHRB + AFBC)

The proposed captive power plant scheme in Unit III for the plant, consist of one no.(1) fluidised bed combustion boiler (FBC) of each 78 TPH capacity with steam outlet parameters of 67ata, 485 Deg.c and one (1) no. 18 MW single extraction cum condensing turbogenerator. The proposed Fluidised combustion boilers are capable of operating round the year with Coal char, washery rejects, and Blast furnace gas.

The captive power plant consisting of the boilers, turbogenerator, auxiliary system, etc. is proposed to be located adjacent to the existing Rotary Kilns. The 12 MW CPP is proposed to be located at the same place. The FBC boilers will operate on Coal char, washery rejects, and Blast furnace gas. One number 85 M high Chimney is envisaged for the boiler.

After meeting CPP’s auxiliary power requirement, the exportable power to sponge iron plant, ferro alloy plant, Steel Rolling mill, mini blast furnaces and their auxiliaries from the CPP, will be fed to the existing 33 kV distribution system.

*Oxygen Plant*

The atmospheric air mainly consists of Oxygen and Nitrogen gases, together with small quantities of water vapour, carbon dioxide and other rare gases such as argon helium etc. Oxygen and Nitrogen from the air can be separated due to the difference in boiling points by distilling them through a fractionating column.

Free atmospheric air is sucked in by a multi stage compressor through a filter and compressed to the working pressure. The compressed air is then passed through a pre-cooling system, dust filters, moisture separators and then to the Molecular Sieve Battery for removing traces of carbon dioxide and moisture from the air. This purified air then passes through the first Heat Exchanger, where it is cooled by the out going Nitrogen and Oxygen. Part of this cooled air then passes through an expansion engine and the other part through the second heat exchanger. Both the expansion engine and second heat exchanger help in cooling down the air further, which is finally released to the bottom of the column through an expansion valve. The air becomes liquid at this stage.

The column is divided into two parts viz., Lower column and Upper column. In between the lower and upper columns there is a condenser which acts as a reflux for the lower column and as a re-boiler for the upper column. The liquid air at the bottom of lower column separates through the trays of the column to give crude Oxygen at the bottom and 97% pure Nitrogen at the top. Crude Oxygen termed as rich liquid is then expanded through an expansion valve from the lower column to the middle of the upper column. Crude Nitrogen termed as poor liquid is expanded through another expansion valve from the top of the lower column to the top of the upper column. Due to difference in the boiling points, the pure Nitrogen boils over and accumulates at the top of the upper column and Oxygen (which has a higher boiling point than Nitrogen) accumulates at the bottom of the upper column. Both Nitrogen and Oxygen are removed by separate pipelines through heat exchangers, for cooling the incoming air, to the filling manifolds for the intended use.

**RAW MATERIALS**

**For Sponge Iron (DRI Division)**

The main raw materials for sponge iron production are iron ore, coal and dolomite. The mix and annual requirement at 100% capacity is as below:

(Quantity in MT)

Particulars/Name of Input	DRI Grade Iron Ore Lumps	Washed Coal	Dolomite
Size	Uncrushed ROM (Run of Mine)	20 mm	1-4 mm
Per MT Requirement	2.000	1.3000	0.050
Product Mix (%age)	59.07%	38.81%	1.49%
Annual Requirement	300000	195000	7500

The technical specifications and sourcing arrangements are as given below:

**DRI Grade Iron Ore**

*Specification:*

The required chemical composition of ore is as under:

Chemical Composition	% Mix
----------------------	-------

Fe (Total)	62 to 65%
SiO <sub>2</sub>	2.0% (maximum)
Al <sub>2</sub> O <sub>3</sub>	3.0% (maximum)
loss of ignition	3.0% (maximum)

***Present Sourcing Arrangements:***

Iron ore is available in the mines at Orissa, Jharkhand, Karnataka, Chattisgarh etc. The nearest iron ore mines are situated at Sundergarh and Keonjhar districts of Orissa. AML is currently fulfilling its requirement from Ganwardhan, Kharbant, Khandadhar, Sekradih mines. AML has installed an iron ore crushing plant at its site for sizing of the iron ore lumps. AML also has an alternate source of supply of crushed iron ore through its associate concern, M/s. Futuristic Steel Private Limited, which has iron ore crushing plant at Joda. As per the information provided by AML, the unit is not facing any problem in procuring the required quantity of iron ore. The Company has a quota allocation from OMC in respect of the purchase of iron ore.

***Proposed Arrangement (Captive Mining):***

AML has fulfilled the eligibility criteria for grant of captive mines as per the Mineral Concession Policy of the State Government. The same has been duly appraised by Industrial Promotion & Investment Corporation of Orissa Limited (IPICOL), the nodal agency for Industrial Development in the State of Orissa. This has been communicated to the Government vide Letter No. SJ/NMPL/FC-23/1140, dated 25<sup>th</sup> June 2005.

Grant Orders for the captive iron ore mines are expected to be awarded by December, 2005. It is expected that once the allotment is made, they can be developed and made ready for mining within a period of 27 months, i.e. simultaneously with the project implementation schedule.

**For Washed Coal**

***Specification***

The required chemical composition of ore is as under:

<b>Characteristics</b>	<b>%</b>
Fixed Carbon	85-87
Ash Content	10-12
Volatile Matter	1-2

***Present Sourcing Arrangements:***

The unit is using washed coal for production of sponge iron. ROM (Run of mine) coal is purchased and is washed in the unit's own coal washery to attain the quality of washed coal fit to be charged in the DRI kilns. AML already has adequate linkage arrangement (12,000Mt /month from Mahanadi Coalfields) which is sufficient to meet its current requirement).

***Proposed Arrangement (Captive Mining)***

AML had applied for a captive coal block for meeting its requirement of coal. AML has been identified as a one of the joint allocatees for a captive coal block of of 60 MMTs extractable reserves at Patrapara (Orissa) in the Mahanadi Coalfield Area, vide Letter no. 13016/33/2005-CA-I dated 13<sup>th</sup> October, 2005.

As per the information provided by AML, the Geological report of the Coal Block is being prepared by Central Mining Planning & Design Institute Limited (CMPDIL), Ranchi, and the same shall be completed and delivered to the Company by end of November 2005, where after a separate study for the Coal mining project would be prepared and activities for acquisition and opening of mines shall be started.

Further, AML has filed an additional application on 16.4.2004 for allotment of Captive Coal Block with Ministry of Coal for 170 MMT extractable reserves. The application is under active consideration of the Ministry. We expect that the unit will be in a position to start its captive mining from April 2008.

**For Dolomite**

*Specification:*

The chemical composition of Dolomite is as under:

<b>Chemical Composition</b>	<b>% Mix</b>
CaO	28 – 30%
MgO	19 – 21%
SiO <sub>2</sub>	25 – 30%
L O I	38 – 41%

***Sourcing arrangements:***

The dolomite quarries of Birmitrapur, Sundergarh district, Orissa, are a good source for DR and BF grade dolomite. These quarries are being operated by M/s. Bisra Stone Lime Co. Ltd. (BSLC). The requirement of the AML is not significant (it being in the nature of a catalyst/flux and the annual requirement across all the facilities is ~37,000MT) and can easily be met from the area.

**For Pig Iron / Hot Metal (MBF)**

Main raw materials required for hot metal production are iron ore, coke, additives and fluxes, viz Limestone, dolomite, quartzite etc. The mix and annual requirement at 100% capacity is as below:

<b>Particulars/Name of Input</b>	<b>(Quantity in MT)</b>					
	<b>BF Grade Iron Ore Lumps</b>	<b>Coke</b>	<b>Sinter</b>	<b>Quartzite</b>	<b>Dolomite</b>	<b>Limestone</b>
<b>Size (mm)</b>	Uncrushed	25-75	10-14	8-30	10-50	10-50
<b>Per MT Requirement</b>	1.592	0.660	0.513	0.060	0.088	0.188
<b>Product Mix (%age)</b>	51.34%	21.28%	16.54%	1.93%	2.84%	6.06%
<b>Annual Requirement</b>	297919	123486	96000	11226	16465	35175

The procurement and technical specifications are as follows:

**For BF Grade Iron Ore**

*Specification:*

The required chemical composition of ore is as under:

<b>Chemical Composition</b>	<b>% Mix</b>
Fe (Total)	61 to 64%
SiO <sub>2</sub>	1.5 to 2.0%
Al <sub>2</sub> O <sub>3</sub>	2 to 3%
L O I	2 to 3.0%

***Sourcing Arrangements:***

There are abundant reserves of BF Grade Iron Ore in the state of Orissa and the unit does not face any problem in procurement of required quantity of iron ore from the various mining companies such as Orissa Mining Corporation (OMC), Orissa Mineral Development Corporation (OMDC) etc. Further, the company is also in talks with SESA Goa for supply of high-grade iron ore. Moreover, with the envisaged captive mining, the cost of ore is expected to reduce considerably.

**For Coke**

Coke is one of the most important raw materials for successful operation of blast furnace. It is desirable that it should have low ash content and high strength.

*Sourcing Arrangements:*

AML imports coking coal and gets it converted into coke in the coke oven plants in the neighboring state of Jharkhand. The Company also has the option of directly importing coke from countries like China, Australia, South Africa, etc. For sourcing the present requirement, the unit has entered into MOU with Tata International Limited for import of coke and is importing the required quantity of coke from China, Australia, etc. AML has also entered into an agreement with Noble Energy, Hong Kong for supply of 25,000 MT of coke. AML has applied for coking coal linkage to Ministry of Steel.

**For Sinter**

Raw materials like iron ore fines, coke breeze, reclaimed flue dust, etc. are generally used for sintering. Most of the fines shall be generated in divisions of AML as waste/by-products.

**For Quartzite**

*Specification:*

The chemical composition is as under:

Chemical Composition	% Mix
SiO <sub>2</sub>	96 – 98%
Fe <sub>2</sub> O <sub>3</sub>	0.2 – 4.0%
Al <sub>2</sub> O <sub>3</sub>	0.5 – 2.8%

*Sourcing Arrangements:*

The quartzite requirement shall be met from the deposits located near Chaibasa, Singhbhum district in Jharkhand.

**For Lime Stone**

*Specification:*

The chemical composition is as under:

Chemical Composition	% Mix
CaO	43.5 – 47 %
MgO	3.5 – 5.5 %
SiO <sub>2</sub>	5.0 – 9.0%
L O I	38 – 41%

*Sourcing Arrangements:*

The source of Lime Stone is Birmitrapur, District Sundergarh, Orissa. The requirement being very small can easily be met from the area.

### **For Ferro Chrome (Ferro Alloy Division)**

Main raw materials required for ferro chrome production are Chrome Ore, Quartz, LAM Coke, BP coal and Dolomite. The mix and annual requirement at 100% capacity is as below:

(Quantity in MT)

<b>Particulars/Name of Input</b>	Chrome Ore Fines	Chrome Ore Lumps	Quartz Dry Sized	LAM Coke	BP Coal	Dolomite
<b>Per MT Requirement</b>	1.700	0.700	0.500	0.352	0.258	0.130
<b>Product Mix (%age)</b>	53.29%	21.94%	1.57%	11.03%	8.09%	4.08%
<b>Annual Requirement</b>	57392	23632	1688	11884	8710	4389

The procurement and technical specifications are given below:

### **For Chrome Ore Fines**

*Specification:*

The chemical composition is as under:

<b>Chemical Composition</b>	<b>% Mix</b>
Cr <sub>2</sub> O <sub>3</sub>	45 – 50 %
SiO <sub>2</sub>	8 - 10 %
Al <sub>2</sub> O <sub>3</sub> , FeO, MgO, etc	30 – 33 %
Phosphorous	0.01 %

*Sourcing Arrangements:*

About 98% of nation's Chromite ore deposits are located in Sukinda, near Jajpur, Orissa. The mines are operated by Tata Steel, OMC etc. The fines generated in crushing of ore is sold by these companies at cheaper rates. AML plans to purchase the required quantity of the ore fines from them.

### **Chrome Ore Lumps**

*Specification:*

The chemical composition is as under:

<b>Chemical Composition</b>	<b>% Mix</b>
Cr <sub>2</sub> O <sub>3</sub>	45 % (min)
SiO <sub>2</sub>	10 % (max)
Al <sub>2</sub> O <sub>3</sub> , FeO, MgO, etc	33% (max)
Phosphorous	0.01 % (max)

*Sourcing Arrangements:*

As stated above, about 98% of the nation's Chromite ore deposits are located in Sukinda, near Jajpur, Orissa. The mines are operated by Tata Steel, OMC etc. The company shall procure the required quantity of the ore from them.

### **For LAM Coke**

*Specification:*

The chemical composition is as under:

<b>Chemical Composition</b>	<b>% Mix</b>
Carbon	85 %
Ash	13 % (max)
Volatile Matter	2%

*Sourcing Arrangements:*

The unit has entered into MoU with Tata International Limited for import of coke and is in the process of entering into similar agreements with other players in the market.

**For BP Coal**

*Sourcing Arrangements:*

The source of BP Coal is Dhanbad, Jharkhand. The requirement being very small can easily be met from the area.

**For Steel Melt Shop**

*The annual requirement of major raw materials at 100% capacity for steel making and their mix is as follows:*

**For Existing Steel Melt Shop No. I** (Quantity in MT)

Particulars/Name of Input	Sponge Iron	Pig Iron (Hot Metal)	Scrap	Calcined Dolomite
Size (mm)	3-18	Liquid	--	--
Per MT Requirement	0.480	0.571	0.097	0.022
Product Mix (%age)	41.01%	48.79%	8.32%	1.88%
Annual Requirement	120000	142750	12464	5500

**For Proposed Steel Melt Shop No. II** (Quantity in MT)

Particulars/Name of Input	Sponge Iron	Pig Iron (Hot Metal)	Scrap	Calcined Dolomite
Size (mm)	3-18	Liquid	--	--
Per MT Requirement	0.822	0.255	0.097	0.022
Product Mix (%age)	68.68%	21.34%	8.14%	1.84%
Annual Requirement	128510	39928	15224	3439

**UTILITIES**

***Water***

Water recirculation systems have been planned to extensively recycle and reuse the return water from plant processes. Industrial quality water as obtained from the source will be used in the secondary side of plate heat exchangers for cooling of process water in the primary side and also for direct cooling circuits. For the primary side, soft water will be re-circulated in closed circuits. Suitable treatment facilities have been planned for open contaminated circuits to render the return water from the unit reusable. Evaporative cooling towers will be provided for cooling industrial water in open circuit recirculation systems. Requirement of water will be fulfilled by the Bore wells set up by AML and by drawing water from river Koel flowing at a distance of 9 Kms from the plant site. AML has already received permission from Government of Orissa in this regard. Apart from this, the company also has an existing water reservoir, which can hold water for 7 days requirement of the plant.

Estimated requirement of water for the various units and process is as below:

Division	Circulation	Make-up	Requirement
----------	-------------	---------	-------------

	(M <sup>3</sup> /hr)	(M <sup>3</sup> /hr)	(M <sup>3</sup> /Day)
Sponge Iron	900	35	840
MBF	1010	63	1512
Ferro Alloys	30	1.50	36
SMS	2300	100	2400
Rolling Mill	1000	20	480
CPP	7000	300	7200
Drinking, Sanitary & Auxiliary	-	8	192
<b>Total:</b>			<b>12660</b>

### ***Steam & Compressed Air System***

Boilers have been installed to provide required process steam for the blast furnace complex. Further, sufficient numbers of fans have been installed to meet the cold blast requirement of the plant. A central compressed air station is meeting the requirement of compressed air for instrumentation and controls, process and service needs of the plant. A network of pipelines has been laid to supply steam, compressed air to the various units.

### ***Fuel Oil System***

Blast Furnace (BF) gas shall be used mainly as fuel in stoves in MBF. In addition to the stoves, small quantity of BF gas shall also be used for cast house runner drying, ladle drying, pig casting machine, pressure equalization at BF top package boiler, etc. The dust laden blast furnace gas after passing through the dust catcher shall be cleaned in the gas cleaning plant. BF gas shall be distributed through a pipeline system operating at a pressure of 600 mmWC.

For meeting the requirements of Furnace oil and Light Diesel Oil, necessary infrastructure like tanks, pumps, pipe lines and dispensing units have been set up which would be further augmented to meet the requirements of the proposed Unit III.

The required fuel is being sourced locally from Indian Oil Corporation.

### ***Oxygen & Argon Facilities***

Oxygen is required mainly for blowing in the EAF for steel making and also for torch cutting of billets in the Continuous Casting Shop, tap-hole opening in the cast house of BF and to meet other general repair needs. Oxygen shall also be required in production of stainless steel in AOD. The division-wise daily requirement of oxygen at 100% capacity is as under:

<b>Name of Division</b>	<b>Requirement of oxygen (SM<sup>3</sup>/day)</b>
MBF	880
SMS	75342
AOD	13562

Billet / Bloom Casting	527
Rolling Mill	1650
General	880
Total per day requirement	92841
Less: Captive Generation	48000
To be purchased per Day	44841

AML is currently producing 19,200 SM<sup>3</sup>/day of Oxygen. After implementation of additional capacity envisaged in the project, the unit would produce about 48,000 SM<sup>3</sup>/day. The balance requirement shall be purchased locally. The company maintains a standby buffer stock of 73 Kilo Litre maintained by BOC & Praxair at the plant site sufficient for 7 days' operations.

Argon is required in the Ladle Furnace for rinsing and AOD for removing carbon content. The required quantity of Argon is being purchased locally.

### **Power**

The division wise power requirement of the plant is as under:

<b>Division</b>	<b>Avg. Load at 100% (MVA)</b>	<b>Avg. Load at 100% (MW)</b>	<b>Million Units p.a. at 100%</b>
Coal Washery	0.70	0.56	4.19
DRI Division	2.50	2.00	14.40
M B F Division	3.00	2.40	19.58
S M S & Concast – I	22.00	17.60	143.62
S M S – II	20.00	16.00	130.56
A O D & Concast	1.00	0.80	6.53
Ferro Alloy Plant	18.00	14.40	114.05
Rolling Mill	8.75	7.00	46.62
Captive Power Plant - 12 MW	1.20	0.96	6.91
Captive Power Plant - 18 MW	1.80	1.44	11.40
Oxygen Plant	2.50	2.00	16.32
Other Utilities	2.00	1.60	13.06
<b>Total:</b>	<b>83.45</b>	<b>66.76</b>	<b>527.24</b>

132 KV Chhind substation of WESCO, Orissa (Western Electricity Supply Company) is located at a distance of about 10 kms from AML's site. Currently the power to the unit is being supplied by overhead conductors at 132 KV with a load of 30 MVA, which can be increased up to 55.9 MVA as per the agreement with WESCO. This increased load along with 30 MW CPP being implemented as part of UNIT II & III, would be able to meet the total requirement of AML. Upon commissioning of the CPP the average per unit cost of power is expected to reduce substantially.

### **Fire Fighting Facilities**

In order to combat any occurrence of fire in the proposed plant premises, fire protection facilities have been envisaged for the various units of the plant. All plant units, office buildings, stores, laboratories, etc will be

provided with adequate number of portable fire extinguishers to be used as first aid fire appliances. A fire hydrant network system has also been envisaged for the plant. Internal hydrants will be provided at suitable locations and at different levels inside the major plant units. Yard hydrants will be provided normally along the road and in the close vicinity of the units. For the current units, fire protection systems are in place commensurate with the size and nature of operations.

## **INSURANCE**

The Company has taken the following insurance policies for its existing operations:

- Machinery Break Down Policy for 5 D.G. Sets
- Stock Policy (Standard Fire & Allied Risk Policy)
- Building, Plant & Machinery etc. (Standard Fire & Allied Risk Policy)
- Loss of Profit Policy
- Schedule Policy
- Marine Policy
- Motor Vehicle Policy
- Workmen Compensation Policy for workers
- Personal Accident Policy for staff

The above have been taken from United India Insurance Co. Ltd., the Oriental Insurance Company Ltd. and Bajaj Allianz General Insurance Company Ltd. All the policies are valid as on date.

The Company proposes to take necessary policies relating to risk during Construction of Building, Transportation of Machines & Equipments, and Erection & Commissioning of Plant & Machinery. The policies listed above for the existing units would also be taken for the new units once the new projects are implemented and the operations commence.

## **HUMAN RESOURCES**

### **Present**

The total manpower as on date is 128, comprising 22 managers, 40 supervisors and 66 workers. Apart from the above, the Company also employs on an average 250 casual/contract labour through its various contractors.

### **Proposed**

In order to operate and maintain the plant facilities, including the technical and general administration needs, the estimated manpower requirement after the completion of the proposed expansions has been estimated to be 1,325 persons. The manpower has been estimated based on the following considerations.

- Production units and their capacities
- Type of equipments proposed for the main production shops and corresponding auxiliary facilities
- Degree of automation and mechanization envisaged in different units.
- Extent of manning required for the various equipments.
- Number of operating shifts
- Supporting personnel for off and leave reserves.

Estimated facility wise requirement of manpower is as given below.

<b>Facility</b>	<b>No. of personnel</b>
DRI	142
Coal Washery	114
MBF	143

SMS	207
Ferro Alloys Division	97
Rolling Mill	140
CPP	105
Mines	81
Common Facility	36
Engineering	136
Sales & Admin	124
<b>Total</b>	<b>1325</b>

The Company proposes to recruit the above personnel at the appropriate time.

### PRODUCTS OF THE COMPANY

At the present the Company is producing Carbon Steel and Alloy Steel Billets through DRI-MBF-SMS-Concast route.

The main grades produced and/or proposed to be manufactured by the Company and their applications are given in the table below:

Sl. No.	Category	Grade	Application / End Use
A.	Carbon Steel		
i)	Low Carbon	0.14% Carbon (Max.) 0.60 Mn (Max)	<ul style="list-style-type: none"> <li>- Cable Armouring Wire</li> <li>- Cable Armouring Tape</li> <li>- MS Bolt / Carriage</li> <li>- Screw</li> <li>- Wood Screw</li> <li>- Forgings</li> </ul>
ii)	Plain Carbon	0.30 to 0.60% Carbon	<ul style="list-style-type: none"> <li>- Wire Ropes</li> <li>- Umbrella Rib</li> <li>- Cycle Spoke</li> <li>- Grade II &amp; III Springs</li> <li>- Vibrating Screen</li> <li>- Shutter Spring</li> <li>- Tyre – bead Wire</li> <li>- ACSR</li> <li>- Bright bar for Auto &amp; Engg. Inds.</li> </ul>
iii)	High Carbon	0.60 to 0.90 % Carbon	<ul style="list-style-type: none"> <li>- PC Single wire &amp; strand</li> <li>- 270K / 250K PC Strand</li> <li>- Piano Wire / Detonator</li> <li>- Spring Wire</li> <li>- Wire Rope</li> <li>- Grade II &amp; Grade III Spring</li> <li>- Spring Washer</li> <li>- ACSR</li> <li>- Needle Wire</li> <li>- Card &amp; Gill Pin for Jute Industries</li> </ul>

B.	Alloy Steel		
i)	Low Alloy Steel	EN 16, EN 17, EN 18, EN 19	<ul style="list-style-type: none"> <li>- Hand Tools</li> <li>- Industrial &amp; Bicycle</li> <li>- Transmitting Chain</li> <li>- Link Chain</li> <li>- Forging Industry for gears, shafts ec.</li> <li>- Bright bars for mainly Auto &amp; Engg. Industries.</li> </ul>
ii)	Spring Steel	EN 45A, 60 Si7, 50 CRV4, 58 CRV4	<ul style="list-style-type: none"> <li>- Leaf Spring</li> <li>- Helical Spring</li> </ul>
iii)	Cold Heading Quality	SAE 1008, 1010, 1015, 1018, 1541	<ul style="list-style-type: none"> <li>- High tensile fastners</li> <li>- Nuts</li> <li>- Self tapping Screws</li> <li>- Cold extrusion</li> </ul>
iv)	Free Cutting	EN1A, EN8M, SAE 1146, En15AM, EN1A	<ul style="list-style-type: none"> <li>- Bright bars for Auto &amp; Engg. Industries</li> </ul>
v)	Special Electrodes	WJM I, WJM II, AS3, AS4	<ul style="list-style-type: none"> <li>- Gas Shielded Electrodes</li> </ul>
vi)	Bearing Grade	En 31, SAE 52100	<ul style="list-style-type: none"> <li>- Balls &amp; Rollers for bearing Industries</li> </ul>
C.	Carbon Construction Steel	EN Series	<ul style="list-style-type: none"> <li>- Bright bars for shock absorbers, rivets and machine component</li> <li>- Automobile axle beam, Piston Rods</li> <li>- For manufacturing heat treated components like shafts, connecting rods</li> <li>- Used for making keys</li> <li>- Engine valve, springs, small washers and stamped parts.</li> </ul>
D.	Alloy Construction Steel		
i)	Mn Cr Steel	27 Mn 2, 17Mn 1 Cr95, 40 Cr1, 40 Cr 4	<ul style="list-style-type: none"> <li>- Bolt, Chain pin, Bright Bars, Pedal shafts</li> </ul>
ii)	Mn Steel	20C15	<ul style="list-style-type: none"> <li>- Link Chain</li> </ul>
iii)	Ni Steel	40 Ni3	<ul style="list-style-type: none"> <li>- Parts requiring high toughness at low temperature</li> <li>- Turbine blades, heavy forgings</li> </ul>
iv)	Ni –Chromium	35 Ni Cr 60 30 Ni 3 Cr 1 30 Ni 4 Cr 1	<ul style="list-style-type: none"> <li>- Crankshafts</li> <li>- Transmission shafts</li> <li>- Cam – shafts</li> <li>- Gear shafts</li> </ul>
v)	Mn – Moly	35 Mn2 Mo28 35 Mn2 Mo45	<ul style="list-style-type: none"> <li>- Wheel studs</li> <li>- Axle shafts &amp; levers</li> </ul>

vi)	Cr-Moly	21 cr 1 Mo 28 40 Cr 1 Mo 28 40 Cr 1 Mo 60 10 Cr s Mo 55	- Mandrels - Cylinder Liners - Roller Shafts, Propeller shafts - Joints
vii)	Ni Cr Moly	40 Ni Cr1 Mo 15 40 Ni2 Cr1 Mo28 31 Ni 3 Cr 65 Mo 55 40 Ni 55 Cr 50 Mo 20	- Gears - Axles - Mandrels - Bars - High tensile bolts & studs axle - Shafts - Crank shaft - Connecting rods
E.	Ball Bearing Steel	103 Cr2 Mn 70/52100	- Ball & Roller Bearing, Collets Shear blades
F.	Creep Resisting Steels	15 Cr 90 Mo 55 20 Cr5 Mo 55	- Forging parts for high temp application
G.	Valve Steels	En 50,52,53,59	- Engine Valve springs
H.	Stainless Steel		
i)	Austenitic		- Chemical Industry - Acetic acid manufacturing equipment - Dyeing Machines, Pulp Industry
ii)	Austenitic ferritic		- Chemical fertilizer industry - Centrifugal separator
iii)	Ferritic		- Trays in Petroleum Refineries
iv)	Martensitic		- Car mufflers - Kitchenware - Hardware - Springs - Surgical Equipment - Dental Equipment
v)	Austenitic		- Cookware - House Clamps - Food Processing equipment - Wheel Cover - Conveyor belts - Kitchen & table utensils - Construction Materials - Parts of furnace - Chimney liner - Nuclear vessel - Home appliances - Car parts - Building Materials - Pulp industry

### Product Mix

The Rolling Mill is being designed to roll the following diverse products:

Sl.No.	Products	Size	Production	Steel Grade & End Use
1.	Medium to Heavy Rounds of different grades	22 to 160 mm Ø	100,000 tpa	Alloy Steel & Carbon Steel for Forging, Automobile, Engg. Chemical, Power Industry.
2.	Medium to Heavy RCS	45 to 160 mm		Alloy Steel for Forging Industry.
3.	Spring Steel & Other Grade Flat	70 x 11, 80 x 11, 90 x 11 and above		Spring Steel for Automobile Industry.
4.	Stainless Steel Flat and rounds	240 x 8/10mm Thick	120,000 tpa	AISI 200 Series Stainless Steel for Utensil Industry.
				AISI 300 Series Stainless Steel for Forging, Automobile, Engg., Chemical Industry

Apart from the above mentioned rolled product the Company will also make different grades of Alloy & Carbon steel billets which will be utilized in different industries depending upon the chemical composition.

## MARKETING & SELLING ARRANGEMENTS

### *(A) Current Arrangements*

Currently the product portfolio of the Company includes Carbon and Alloy Billets. The product portfolio of the Company following the implementation of phase II of the project would comprise auto-grade and special steel and stainless steel.

The Company is also planning to roll a part of its billets production to manufacture rolled products and cater to the demand of that market. The group is having a rolling mill at Durgapur, which will be used for rolling of billets manufactured by AML. Further the Company is in discussion with other rolling mills situated nearby for rolling of its billets.

These products are manufactured according to technical specifications desired by the buyers. The Company has presently a wide network of selling agents which will be used for selling of the Companies products. Besides the above the Company has also an efficient marketing team which will be used for controlling of the agent as well as direct marketing of the products to the large manufacturers.

The Company has already obtained the necessary ISO-9000 certification for its products..

The Company has recently entered into several Memorandum of Understanding (MoU) with customers having approvals from leading OEMs in the automobile sector for supply of various grades of special and alloy steel products. The major of them are as follows:-

<i>Name of Party</i>	<i>Quantity of Off-take (tonnes per annum)</i>
<i>Jai Parabolic Springs</i>	<i>40,000</i>
<i>Jamna Auto Industries Ltd.</i>	<i>40,000</i>

<i>JMT Auto Ltd.</i>	<i>18,000</i>
<i>Sharu Steel (P) Ltd.</i>	<i>18,000</i>
<i>R.L. Steels Ltd.</i>	<i>12,000</i>
<i>Arjan Das &amp; Sons</i>	<i>10,000</i>
<i>CSIA Steels Pvt. Ltd.</i>	<i>5,000</i>
<i>Eknath Rolling Mills Pvt. Ltd.</i>	<i>4,000</i>
<i>Akar Tools Ltd.</i>	<i>3,500</i>
<i>V Cube Forge (India) Ltd.</i>	<i>3,500</i>
<i>Harig Crankshafts Ltd.</i>	<i>2,500</i>
<i>Super Forging and Steels Limited</i>	<i>6,000</i>
<i>Mode Forge (Pvt) Ltd.</i>	<i>12,000</i>
<i>Coromandel Forge Pvt. Ltd.</i>	<i>15,000</i>
<i>Super Steel Forging Limited</i>	<i>12,000</i>
<i>Forge Well Limited</i>	<i>7,000</i>
<i>SPM Auto Pvt. Ltd.</i>	<i>5,000</i>
<i>Sharu Special Alloys (Pvt.) Ltd.</i>	<i>5,000</i>
<i>Emson Tools Mfg. Co. Ltd.</i>	<i>10,000</i>

Apart from the above the Company has strong marketing tie up with Tata Steel to whom the Company sells its left out Sponge Iron and Pig Iron after meeting its captive requirements.

***(B) Proposed Arrangements***

In Adhunik Metaliks, we will be manufacturing various grades of special/alloy and stainless steel which are suitable for automobile, engineering, utensils, and seamless tube industry. Products like stainless steel flats to be produced by our new plant will have applications in Petro chemical, Food processing, Pharmaceutical, Interior decoration etc.

We have already taken the necessary steps for the approval of our existing products by M/s. RDSO, Tata Motors, Bharat Forge, Maruti Suzuki, Ford, Hyundai and quite hopeful of getting the same. Once the approvals are received the Company will enter into long term marketing tie-up with these companies. All the OEM's will be serviced through a strict Quality System based manufacturing and delivery process. More and more use of JIT concepts in our delivery system is getting adopted. A necessary marketing network, associated with Company stockyards in important areas is getting developed.

Latest concepts like TPM, QS-9000 etc. are being adopted to have an edge in the market. Strategic relationship with big customers like Tata Steel is in place to supply billets, pig iron and sponge iron.

**Business Strategy:**

The Company's strategy is to operate the business in an efficient & effective way so as to supply quality steel products & solutions that satisfy its customer's needs and add value to its stakeholders. The focus of

AML will be to increase the contribution on the products by reducing the cost of production, control over logistics, by ensuring uninterrupted raw material supply, command high prices through value added products and to ensure long term sustainability of the Company.

## COMPETITIVE STRENGTHS

India has manufactured much of its steel traditionally through the ingot route (employed mainly by merchant producers) as against the continuous casting route (employed by integrated producers). The main reasons for this has been the fragmented nature of the steel industry, impaired access to capital by steel manufacturers, low capital cost of merchant units and low gestation of merchant plants. Today the incentive for setting up merchant units is increasingly reduced. Integrated producers are better placed on account of:

- Better cost structure due to multipoint value addition and economies of scale.
- Better technology resulting in lower costs and better quality.
- Better access to capital due to size.
- Better pricing control and access to markets.
- Proximity to the availability of Raw materials
- Long-term access to raw materials thereby increasing immunity to the steel cycle.

Availability of key raw materials will be a limiting factor for growth of small non-integrated producers. However, with the proposed allotment of iron ore and coal mines, AML will be placed advantageously as compared to other steel manufacturer.

The Company believes that the following strengths will enable it to ward off the threat of competition:

- *Experience:* The promoters of AML have about three decades of experience in the iron & steel business.
- *Quality Produce:* AML has been consistently focusing on quality and conforms to international quality standard ISO 9001.
- *Lower Cost of Production:* Post implementation of the Unit III, AML will have captive mines for iron ore and coal and its own Captive Power Plant to meet its power requirement. Further the Company is looking favorably for investment through equity in coal mine at Australia. These will insulate the Company from any movement in the prices of its key raw materials.
- *Growth Strategy:* The Company will manufacture various high grades of steel catering to various growth industries including engineering and auto sector. These products command good premium in the market and AML will find itself on strong footing with the commissioning of its rolling mill and various other value added manufacturing facilities as proposed in the project.

## Adhunik Metaliks Competitive Value Chain

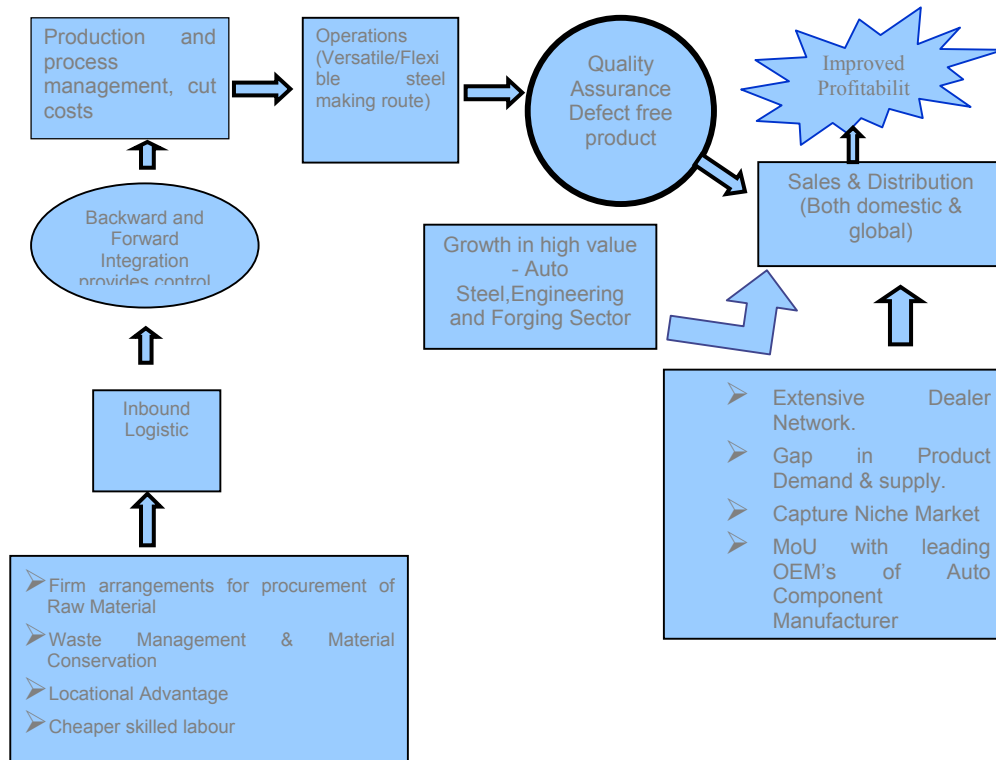

## ENVIRONMENTAL COMPLIANCE

The pollutants in the form of solids, liquids and gases are generated from various units of steel plant and if let out as such, will have hazardous effects on the environment. Pollution of the environment not only adversely affects the human beings, flora and fauna but also shortens the life of plant and equipment. This vital aspect, therefore, has been taken into account while planning the plant and equipment and adequate measures have been proposed to limit the emission of pollutants within the stipulations of statutory norms.

### Air pollution control

The measures to control the air pollution will ensure the ambient air quality standards as laid down by Central Pollution Control Board for industrial and mixed-use areas. Some of the measures currently in place and proposed to be implemented by AML are as below:

- Adoption of technology like recovery of heat from DR off gas for use as fuel, that fulfills the twin objectives of energy conservation & pollution control.
- Raw material storage yard: The suspended particles is controlled by sprinkling water through sprinklers.
- Batching and conveying of raw materials to kilns: Sufficient capacity bag filter have been installed to control the emission problem
- Installation of Electro-Static Precipitator & Magnetic separators.
- In rolling mill, hot flue gases shall be discharged to open atmosphere at a height of 36 M through a recuperator & chimney.

### **Water Pollution Control**

The pollutants present in the wastewater will be reduced to acceptable levels by adoption of the following schemes:

- Re-circulating water in the process and blow down to specific process whereby discharged volume is negligible.
- Close circuit cooling wherever feasible.
- Clarifier and sludge pond for removal of suspended solids.
- Removal of oil and grease from the contaminated water by means of oil traps and skimming devices.
- Storm Water Drainage

### **Noise Pollution Control**

Various measures proposed to reduce the noise levels include reduction of noise at source, provision of acoustic lagging for the equipment and suction side silencers, selection of low noise equipment, isolation of noisy equipment from working personnel. In some areas where due to technological process, it is not feasible to bring down the noise level within acceptable limits, personnel working in these areas will be provided with noise reduction aid such as ear muffler and also the duration of exposure of the personnel will be limited as per the norms.

### **Green belt**

Adequate green belt is being provided all around the plant and inside the plant premises. Locally available types of trees, which are resistant to pollutants are being planned to be grown.

## **CORPORATE SOCIAL RESPONSIBILITY**

The group has always been proactive towards its social responsibilities outside the ambit of group human resources development. Though still in its nascent stage, the Company has launched an impressive community development program for the benefit of the local people and community, like:

The Company is a member of Periphery Development Committee (PDC), formed by the Government of Orissa at Block and District levels PDC and carries out the developmental activities as per the decisions and directions of this Committee. Some of the main development schemes implemented by Company during the current year are:

- Excavation of 4 nos. of ponds in the Villages of the periphery.
- Provision of water by repairing existing tube wells and sinking new tube wells, etc.
- Promoted education for children of the village by repairing and up-grading schools at Ratakhandi Village's and Chadrihariharpur, installing computer in the village.
- Providing medical facilities for the residents of the area like, ambulance, mobile clinics with doctors, medicines and paramedic staff, free health check-up camps at regular intervals.

Apart from the above, the Company is operating a number of other peripheral and community development schemes to improve the local habitat and quality of life of the local people. Some of the steps taken in the direction are:

- ⇒ Schemes relating to improvement of local habitat like, water management, plantation and forestry activities, development of roads and other infrastructures, etc.
- ⇒ Schemes relating to Augmentation of Income, like provision of free water for irrigation, development of agriculture, animal husbandry, poultry and fisheries projects, etc.
- ⇒ Schemes relating to improvement of health, like, arranging regular health check-up camps, setting a network of small dispensaries, provision of free ambulance facility, etc.
- ⇒ Schemes relating to enhancement of Education, like, up gradation of existing schools in the villages, scholarship and financial assistance to meritorious students, training schools for ladies, etc.
- ⇒ Setting up of a technical institute for improving the skills and knowledge of the local residents.

## PROPERTY

### Existing Manufacturing Units:

We have immovable properties at our manufacturing units and we are giving below a brief summary of our immovable properties related to the same:

The land measuring 17.02 acres has been acquired for the expansion. Out of this, 4.08 acres of land is purchased in the name of AML while the remaining land is purchased in the name of Smt. Chandrakanta Agarwal and Smt. Sonika Agarwal who are related to the promoters. The land purchased in the name of Smt. Chandrakanta Agarwal and Smt. Sonika Agarwal is leased to AML for 15 years with a lease rent of Rs. 4,000/- per annum. The cost of purchased land is Rs. 0.02 crores. The land owned by the Company has been purchased from individuals and free from all encumbrances and has clear title.

Apart from the above, there are properties (in the form of leasehold land) purchased by our Directors and which have been leased out to the Company. The details of the same are given in the table below:

<b>Name of Director</b>	<b>Property Details</b>	<b>Mode of Interest</b>
Mr. Jugal Kishore Agarwal	Land measuring about 3.96 acres situated at Vill: Chadrihariharpur. Orissa	Given Lease to the Company for a period of 15 years commencing from 9 <sup>th</sup> August 2004
Mr. Nirmal Kumar Agarwal	Land measuring about 5.28 acres situated at Vill: Chadrihariharpur. Orissa	Given Lease to the Company for a period of 15 years commencing from 9 <sup>th</sup> August 2004
Mr. Ghanshyamdas Agarwal	Land measuring about 6.55 acres situated at Vill: Chadrihariharpur. Orissa	Given Lease to the Company for a period of 15 years commencing from 9 <sup>th</sup> August 2004

***Details of Offices and Other Properties:***

Set forth below are the details of our offices and other properties:

<b>Sl. No.</b>	<b>Description</b>	<b>Address</b>	<b>Owned/Rented</b>
1.	Regd. Office	14, N.S. Road Kolkata – 700 001	Rented
2.	Corporate Office	2/1A, Sarat Bose Road Lansdowne Towers Kolkata – 700 020	Rented
3.	Factory Site	Chadrihariharpur Sundergarh Orissa	Partly Owned. Part of the land is leased from promoters. For details please refer to para under” Interest of Directors” on page no. 115 of this Prospectus.
4.	Branch Office	2, Inner Circle Road, Shanti Hari Tower, Bistupur, Jamshedpur	Rented
5.	Branch office	H-3, Civil Township, Rourkela, Orissa	Rented

There are no further approvals/clearances required to be taken in respect of any of the land/property listed above.

**Purchase of Property**

The Company does not propose to purchase any property out of the proceeds of the issue

## HISTORY OF OUR COMPANY AND OTHER CORPORATE MATTERS

### **Incorporation**

Our Company was incorporated on November 20, 2001 as Neepaz Metaliks Private Limited under the provisions of the Companies Act, 1956 with its registered office at 14, N.S. Road, Kolkata 700 001. Subsequently, the Company converted into a public company pursuant to a special resolution passed on February 18, 2004 and filed the statement in lieu of prospectus as required under the section 44(2) (b) of the Companies Act, 1956. The name of the Company was changed from Neepaz Metaliks Limited to Adhunik Metaliks Limited pursuant to a special resolution passed by the shareholders of the Company at a meeting held on July 22, 2005.

As on the date of filing this Prospectus, our Promoters hold 5,16,85,642 Equity Shares of our Company representing 80.51 of our pre - Issue issued equity capital and the Promoter Group holds 67,13,770 Equity Shares of our Company representing 10.46 per cent of our pre - Issue issued equity capital. As on the date of filing this Prospectus, six of the Directors on our Board represent the Promoters of whom one is an executive director and three of the Directors are independent directors.

### **Objects of our Company**

Our main objects as contained in our Memorandum of Association are:

1. To carry on business as traders, manufacturers, contractors, processors, dealers, buyers, sellers, importers, exporters, indentors, fabricators, engineers, merchants, stockists, suppliers, distributors, transporters, agents, representatives, commissioner brokers, liaison job agents and consignors of all kinds and forms of iron and steel goods, ferrous and non-ferrous metals, ferro alloys, sponge iron and ferrous and non ferrous scrap in eluding mild steel scrap, cast iron scrap, pig iron, m.s.melting scrap, m.s. turning and boring, unserviceable steel drums and barrels, grinding dust, alloy steel skull, milds, high carbon, spring high speed tool, alloy stainless and special steel, ingots, billet, steel castings, rounds, flats, stripes, angels, channel plates, bars, joists rods, structural tube pipes, wire rolling, materials, old railway materials i.e. rails wheels axels and other fillings of scrap and agro implements and tools.
2. To undertake the business as iron master, iron and steel makers, steel founders, steel converters, steel fabricators, extruders, iron ore miners, steel reproprocessors and rerollers, metallurgist, smelters and as manufacturers of and dealers in ferrous and non-ferrous castings and forgings of all types.

The main objects as enlisted above enable us to carry on our present operations as well as the ones proposed in the expansion project.

### **Changes in our Memorandum of Association**

Since the incorporation of our Company, the following changes have been made to our Memorandum of Association:

<b>Date of shareholder approval</b>	<b>Changes</b>
March 30, 2002	The authorised share capital of the Company was increased from Rs 10 lacs to Rs. 1 crore
January 30, 2003	The authorised share capital of the Company was increased from Rs. 1 crore to Rs. 1 crore 20 lacs

October 6, 2003	The authorised share capital of the Company was increased from Rs. 1 crore 20 lacs to Rs. 15 crores 20 lacs
January 5, 2004	The authorised share capital of the Company was increased from Rs 15 crores 20 lacs to 20 crores
February 18, 2004	The authorised share capital of the Company was increased from Rs. 20 crores to Rs. 36 crores and the Company was converted into public company and consequently the name was changed from Neepaz Metaliks Private Limited to Neepaz Metaliks Limited
March 25, 2004	Fresh Certificate of Incorporation subsequent to change of name from Neepaz Metaliks Private Limited to Neepaz Metaliks Limited
September 20, 2004	The authorised share capital of the Company was increased from Rs. 36 crores to Rs. 60 crores
March 20, 2005	The authorised share capital of the Company was increased from Rs. 60 crores to 75 crores.
July 22, 2005	The name of the Company was changed from Neepaz Metaliks Limited to Adhunik Metaliks Limited
August 9, 2005	Fresh Certificate of Incorporation subsequent to change of name from Neepaz Metaliks Limited to Adhunik Metaliks Limited.
January 5, 2006	The authorised share capital of the Company was increased from Rs. 75 crores to 100 crores.

For details of the capital raised by our Company please refer to the chapter on Capital Structure on page 13 of this Prospectus.

### **History and Major Events**

We have enumerated hereunder a synopsis of the major events in the history of our Company.

S.N.	PARTICULARS	
1.	Allotment of 6.910 acres of government land in village Chadriharipur (Ac. 0.510) & Kalosihira (Ac. 6.400) for establishment of sponge iron plant	Our Company vide order dated March 1, 2005 issued by the Orissa Industrial Infrastructure Development Corporation has been allotted 6.910 acres of government land on leasehold basis for period of 90 years. Pursuant to the aforesaid order, our Company entered into a lease agreement dated March 19, 2005 with the Orissa Industrial Infrastructure Development Corporation (OIIDC) for the allotment of the aforesaid 6.910 acres of land for a period of 90 years subject to the terms, conditions and restrictions imposed therein. The possession of said government land was handed over to our Company on April 29, 2005 under a certificate of possession issued by the Deputy Manager (Land), IDCO, Bhubaneswar.
2.	Provisional allotment and identification as joint allottee for captive coal block of Patrapara in MCL area.	Pursuant to the discussions at the 20 <sup>th</sup> meeting of the Screening Committee, Ministry of Coal held on June 6, 2003 for screening proposals relating to captive mining of coal/lignite, it provisionally allocated a block for the purposes of exploration through CMPDIL to our Company. Our Company by letter dated April 16, 2004 issued to the screening committee, Ministry of Coal requested for allotment for an additional

		block of coal in view of expansion of its existing project thereby creating a requirement for more coal.
--	--	--

### **Summary of Key Agreements**

We have detailed below a summary of the significant provisions of certain schemes / agreements / memorandums of understanding entered into by our Company for acquisition and strategic investments.

#### **Scheme of Amalgamation with Adhunik Mineral and Alloys Limited**

Our Company entered into a scheme of amalgamation with Adhunik Minerals and Alloys Limited, which was sanctioned by the High Court of Calcutta on April 11, 2005 and which became effective from May 19, 2005. Upon the sanction of the scheme of amalgamation, our Company issued and allotted to every equity shareholder of Adhunik Minerals and Alloys Limited one equity share of Rs. 10/- each credited as fully paid up in our Company in lieu of their shareholding in Adhunik Minerals and Alloys Limited. The value of the equity shares aggregated to Rs.4 crores. As a result of the said scheme of amalgamation our Company acquired the whole of the undertaking of Adhunik Minerals and Alloys Limited together with all its assets and liabilities.

#### **Memorandum of Understanding with the Government of Orissa**

Our Company entered into a memorandum of understanding dated October 1, 2003 with the Government of Orissa for setting up a 0.41 MTPA steel plant and 70MW captive power plant at Chadrihariharpur near Rourkela in the district of Sundergarh, Orissa (“MOU”). Under the terms of the MOU, the Government of Orissa has agreed to render assistance in providing land, iron ore mines and to make a recommendation to the Government of India for allotment of suitable coal blocks for captive coal mining for the project either directly or through a public sector undertaking. It has also been agreed that the Government of Orissa will assist the Company to obtain the allocation of coal linkage of suitable grade in the desired quantity to meet the requirement of the Company until allotment of the coal block.

The Government of Orissa has also agreed to assist the Company in making a firm arrangement with Orissa Mining Corporation (“OMC”) along with other private iron ore lessees in the State for the initial period of the project. It has further been agreed that the Company shall be given priority in the matter of applications for iron ore mines under the Mines and Minerals (Regulation and Development) Act, 1957 and Mineral Concession Rules, 1960.

The Government of Orissa has agreed to permit withdrawal of water from Sankh river and/or a suitable source under appropriate approval of the Water Allocation Committee. It has also agreed to permit implementation of a water supply scheme to be prepared by the Company and Water Resources Department subject to the consent of the Rourkela steel plant.

The Government of Orissa has also agreed to assist the Company in obtaining necessary no objection certificates from the State Pollution Control Board and all other environmental clearances from the appropriate authorities. The Government of Orissa has also agreed to implement a rehabilitation and resettlement package as per applicable law for the rehabilitation of displaced families.

The MOU is valid for a period of two years from the date of signing and may be extended by mutual agreement though such extension shall only be considered on substantial progress on the implementation of the project in terms of construction, erection of plant and machinery by the Company.

This MOU was extended vide letter dated October 29, 2005 for a period of two years from October 10, 2005 to September 30, 2007 for setting up of the steel plant project.

### **Agreement with Indian Oil Corporation Limited**

Our Company has entered into an agreement dated September 23, 2004 with Indian Oil Corporation Limited for the hire and supply of consumer petrol and high speed diesel pump outfit for the purpose of storage and use of the high speed diesel by the Company. The Company has agreed to bear all loss of product either partial or entire and no claim against M/s. Indian Oil Corporation can be raised. The Company has agreed to procure and maintain the licence for storage of the high speed diesel under the provisions of the Petroleum Act, 1934 and other applicable laws. Pursuant to this agreement our Company has procured the licence for storage of the high speed diesel.

### **Agreement with the Government of Orissa, Water Resources Department**

Our Company entered into an agreement dated July 16, 2005 with the Government of Orissa, Water Resources Department for the use of an intake well and pump house of the defunct Koel Mega Lift Irrigation Project on river Koel. Under the terms of the agreement, we have agreed to install a separate pumping point of 300 acres at our own cost which is to be handed over to the registered *Pani Panchayat* for operation and maintenance. Our Company will be held responsible in the event water supply from the said pumping point is stopped during the period of cultivation bringing loss to the standing crop. The design and estimate of the new project or any alteration in the existing structure will require the prior consent of Orissa Lift Irrigation Corporation.

### **Coal supply agreement with Mahanadi Coalfields Limited**

Our Company has entered into an agreement dated March 11, 2004 with Mahanadi Coalfields Limited for the purchase of coal for self-consumption in the sponge iron plant, pursuant to linkage granted by Standing Linkage Committee (Long Term) vide Ministry of Mines & Minerals Department of Coal, Government of India.

Our Company has deposited a sum of Rs 1,500,000/- (Rupees fifteen lacs only) equivalent to the base price of coal prevalent on the date of deposit multiplied by 10/365 days equivalent to the annual contract quantity as security deposit. The annual contract quantity is 144,000 TPA Gr. F coal.

Our Company has agreed to compensate Mahanadi Coalfields Limited as per the terms of the agreement in the event of failure to purchase the contracted quantity of coal.

### **Agreement with Grid Corporation of Orissa Limited**

Our Company has entered into an agreement dated September 17, 2004 for the purpose of depositing Rs 10 lacs per MW amounting to Rs 270 lakhs on maximum demand basis with GRIDCO as an interest bearing loan @ 6% per annum for the up-gradation of the auto-transfer for the purpose of power supply. In accordance with the agreement, our Company has deposited the entire amount which is to be adjusted in 60 monthly installments from the electricity bill to be paid by our Company to WESCO in lieu of the power supply availed from WESCO. Our Company has agreed that in the event power supply is not availed, the entire deposit amount will stand forfeited and penalty @ 12% per annum shall be paid to GRIDCO on the total amount payable as advance for the delayed period of availing power supply.

### **Agreement for supply of electrical energy from Western Electrical Supply Company of Orissa Limited**

Our Company has entered into two agreements with Western Electrical Supply Company of Orissa Limited dated May 4, 2004 and October 6, 2005 respectively.

The supply of the electrical energy is under the terms and conditions stipulated under *Orissa Electricity Regulatory Commission Distribution (Condition of Supply) Code, 1998*.

The agreement dated May 4, 2004 is for the supply of electrical energy for the consumption of our Company in the integrated steel and ferro alloys plant as also for the residential colony of our employees. The tenure of the agreement is for a period of five years from the date of payment of the security deposit paid by our Company. The total power available under this agreement is 50 MW.

The agreement dated October 6, 2005 is for electrical supply for the purpose of the sponge iron plant of the Company and supercedes the earlier agreement dated May 11, 2004 for supply of 2000 KVA power. By the agreement of October 6, 2005, 3500 KVA of power is being supplied to our Company and the liabilities and arrears of the earlier agreement is treated as the liabilities of this agreement. The duration of the agreement is five years from the date of supply.

#### **DIVIDENDS**

Since its incorporation, the Company has not declared any dividend.

## MANAGEMENT

### Board of Directors

The following table sets forth details regarding our Board of Directors as on January 9, 2006:

Sr. No.	Name, Designation, Father's Name, Address, and Term	Address	Age (years)	Other Directorships in Indian companies
1.	Ghanshyamdas Agarwal, S/o Late Mr.Mahadeo Prasad Agarwal Designation: Chairman Occupation: Business Term: Liable to retire by rotation	BA-209, Salt Lake City, Kolkata 700 064	48	<ul style="list-style-type: none"> <li>• Adhunik Alloys &amp; Power Limited</li> <li>• Adhunik Metaliks Limited</li> <li>• Neepaz Tubes Pvt. Limited</li> <li>• Adhunik Infotech Limited</li> <li>• Adhunik Meghalaya Steels Private Limited</li> <li>• Adhunik Steels Limited</li> <li>• Adhunik Coporation Limited</li> <li>• Mahananda Suppliers Ltd</li> <li>• Sungrowth Shares &amp; Stock Limited</li> <li>• Adhunik Thermal Energy Limited</li> </ul>
2.	Jugal Kishore Agarwal S/o Late Mr.Mahadeo Prasad Agarwal Designation: Director Occupation: Business Term: Liable to retire by rotation	BA-209, Salt Lake City, Kolkata 700 064	54	<ul style="list-style-type: none"> <li>• Adhunik Ispat Limited</li> <li>• Adhunik Infotech Limited</li> <li>• Adhunik Alloys &amp; Power Limited</li> <li>• Adhunik Metaliks Limited</li> <li>• Adhunik Meghalaya Steels Private Limited</li> <li>• Adhunik Steels Limited</li> <li>• Adhunik Coporation Limited</li> <li>• Mahananda Suppliers Ltd</li> <li>• Sungrowth Shares &amp; Stock Limited</li> <li>• Adhunik Thermal Energy Limited</li> </ul>
3.	Nirmal Kumar Agarwal S/o Late Mr.Mahadeo Prasad Agarwal Designation: Director Occupation: Business Term: Liable to retire by rotation	BA-209, Salt Lake City, Kolkata 700 064	43	<ul style="list-style-type: none"> <li>• Adhunik Alloys &amp; Power Limited</li> <li>• Adhunik Meghalaya Steels Private Limited</li> <li>• Adhunik Infotech Limited</li> <li>• Adhunik Metaliks Limited</li> <li>• Adhunik Metcoke Pvt. Limited</li> <li>• Adhunik Steels Limited</li> <li>• Adhunik Coporation Limited</li> <li>• Mahananda Suppliers Ltd</li> <li>• Sungrowth Shares &amp; Stock Limited</li> <li>• Adhunik Thermal Energy Limited</li> </ul>

4.	Mohan Lal Agarwal S/o Late Mr.Mahadeo Prasad Agarwal Designation: Director Occupation: Business Term: Liable to retire by rotation	BA-209, Salt Lake City, Kolkata 700 064	40	<ul style="list-style-type: none"> <li>• Adhunik Meghalaya Steels Private Limited</li> <li>• Adhunik Metaliks Limited</li> <li>• Adhunik Infotech Limited</li> <li>• Adhunik Steels Limited</li> <li>• Adhunik Coporation Limited</li> <li>• Mahananda Suppliers Ltd</li> <li>• Sungrowth Shares &amp; Stock Limited</li> <li>• Adhunik Thermal Energy Limited</li> </ul>
5.	Mahesh Kumar Agarwal, S/o Late Mr.Mahadeo Prasad Agarwal Designation: Director Occupation: Business Term: Liable to retire by rotation	BA-209, Salt Lake City, Kolkata 700 064	39	<ul style="list-style-type: none"> <li>• Adhunik Alloys &amp; Power Limited</li> <li>• Adhunik Metaliks Limited</li> <li>• Adhunik Meghalaya Steels Private Limited</li> <li>• Adhunik Steels Limited</li> <li>• Adhunik Infotech Limited</li> <li>• Adhunik Coporation Limited</li> <li>• Adhunik Ispat Limited</li> <li>• Mahananda Suppliers Ltd</li> <li>• Sungrowth Shares &amp; Stock Limited</li> <li>• Adhunik Thermal Energy Limited</li> </ul>
6.	Manoj Kumar Agarwal S/o Late Mr.Mahadeo Prasad Agarwal Designation: Managing Director Occupation: Business Term: Whole time non retiring director Tenure as Managing Director ends on March 14, 2009	BA-209, Salt Lake City, Kolkata 700 064	36	<ul style="list-style-type: none"> <li>• Adhunik Ispat Limited</li> <li>• Adhunik Infotech Limited</li> <li>• Adhunik Alloys &amp; Power Limited</li> <li>• Adhunik Metaliks Limited</li> <li>• Neepaz Tube Pvt. Limited</li> <li>• Adhunik Meghalaya Steels Private Limited</li> <li>• Adhunik Steels Limited</li> <li>• Adhunik Coporation Limited</li> <li>• Mahananda Suppliers Ltd</li> <li>• Sungrowth Shares &amp; Stock Limited</li> <li>• Adhunik Thermal Energy Limited</li> </ul>
7.	L. M. Chatterjee (Independent Director) S/o Late R. G. Chatterjee Designation: Director Occupation: Consultant Term: Liable to retire by rotation	23, Contatctor Area, Bistopur Jamshedpur 831001	70	Nil

8.	Supriya Gupta (Independent Director) S/o. Late S. Gupta Designation: Director Occupation: Consultant Term: Liable to retire by rotation	2A, Dover Apartment, 18/1 Dover Place ( 2 <sup>nd</sup> Floor )Kolkata- 700 019	69	<ul style="list-style-type: none"> <li>• Bengal Tea &amp; Fabrics Limited</li> <li>• Kanoria Chemicals &amp; Industries Limited</li> <li>• NABIA Bank Limited( Nepal)</li> <li>• Taj Asia Limited</li> <li>• Kirti Vardhan Finvest &amp; Services Limited</li> <li>• Vivekananda Sky Road Limited</li> <li>• Bhansali engineering Polymers Limited</li> <li>• Upper Ganges Sugar &amp; Industries Limited</li> <li>• G.I.S. Ltd</li> <li>• Hindustan National Glass &amp; Industries Limited</li> <li>• Indessa Gases Private Limited</li> <li>• Suryachakra Power Corporation Limited</li> </ul>
9.	Nihar Ranjan Hota (Independent Director) S/o Shri S. C. Hota Designation: Director Occupation: Consultant Term: Liable to retire by rotation	'Abhilasha' 6A, Forest Park, Bhuwenaswar, Orissa - 751009	70	Nil

#### Details of Directors

##### Mr. Ghanshyamdas Agarwal

Mr. G. D. Agarwal (48 years) is a commerce graduate from Calcutta University. He has over 2 decades of experience in the steel sector in the areas of trading and providing services to manufacturing units in this segment. Mr. Agarwal pioneered the investment of the group into Ferro Alloys by setting up a plant in Meghalaya under the aegis of Adhunik Meghalaya Steels (P) Limited. As the chairman of the company he has been instrumental in defining the investment plans of the Company. His entrepreneurship has been awarded with the 'Bharitya Udyog Ratan' awarded by Indian Economic Development & Research Association, New Delhi.

##### Mr. Manoj Kumar Agarwal

Mr. M. K. Agarwal (36 years), our Managing Director is an graduate of engineering from REC Kurukshetra. He has more than a decade of experience in the steel sector in the areas of trading and providing services to manufacturing units in this segment. Mr. Agarwal has played an integral role in visualizing the growth road map of the group. Under his able leadership our Company has witnessed incomparable growth both in terms of setting up competitive manufacturing facilities and profitability. Mr. Manoj Agarwal is a dynamic entrepreneur and has been a major influence in shaping up the future operations of the group under his leadership the Company has been able to convince the State Government of Orissa to enter into a memorandum of understanding and recommend the mining leases for coal and iron ore.

##### Mr. Jugal Kishore Agarwal

Mr. J. K. Agarwal (54 years) is a law graduate from Calcutta University. He has almost 3 decades of experience in the steel sector in the areas of trading and providing services to manufacturing units in this segment. Mr. Agarwal has been a guiding force behind the group and has played a key role in envisioning the various business initiatives of the group. He has expertise in financial matters and has been an important contributor in all the financial matters of the group.

**Mr. Nirmal Kumar Agarwal**

Mr. N.K. Agarwal (43 years) is a science graduate. He has about 2 decades of experience in the steel sector and has been mainly involved in the trading activity of the group. Under his able guidance the group started operations in Mandi Gobindgarh, Punjab the hub of steel trading in India. Mr. Agarwal is keenly involved with various industrial associations and is currently the regional director of Sponge Iron Manufacturers of India.

**Mr. Mohan Lal Agarwal**

Mr. M. Agarwal (40 years) is a commerce graduate from Calcutta University. He has more than 15 years of experience in the steel sector in the areas of trading and providing services to manufacturing units in this segment and is responsible for the day-to-day management of the plant.

**Mr. Mahesh Kumar Agarwal**

Mr. M. K. Agarwal (39 years) is a commerce graduate from Calcutta University. He has over 14 years of experience in the steel sector in the areas of trading and providing services to manufacturing units in this segment. Mr. Agarwal has hands on experience in all the accounting and financials of the Company, he has been the front-runner in terms of project execution in West Bengal and is credited for setting up the first sponge iron plant and rolling mill of the group in the year 2001. He is the managing director of Adhunik Corporation Limited.

**Mr. Nihar Ranjan Hota**

Mr. N. R. Hota (70 Years) is an independent Director on the Board of our Company. He is an M.A in Development Economics from Williams College, USA, and M. Phil in Public Administration from Punjab University. He is a retired IAS officer having 33 years experience from 1960 to 1993, holding various responsible positions under the state and central government and retired as Chief Secretary to the Government of Orissa. He was also a Member, Orissa State Finance Commission from 2003 to 2004. Mr. Hota had worked in public sectors like Orissa Construction Corporation as chairman, Food Corporation of India as regional manager, Aska Sugar Industries Limited as managing director. He was the chairman cum managing director in Industrial Development Corporation Of Orissa from 1990 to 1993. He has worked in relevant allied sectors of power and mining as secretary to the Government of Orissa. His corporate experience includes directorship of Konarak Metcoke Limited.

**Mr. Lalit Mohan Chatterjee**

Mr. Chatterjee aged about 70 years, is an independent Director of the Board of our Company. Mr. Chatterjee is a B.E. (Mech) from Calcutta University. He has also completed a diploma course in mechanical & electrical engineering from S. N. T. I. Mr. Chatterjee started his carrier with Tata Steel Limited as a graduate trainee. He nurtured his skills and proved his ability and has successfully associated with Tata Steel Limited with more than 4 decades. He retired as deputy general manager and since then he is associated with various companies as a consultant. His knowledge in iron making and ferro alloys has been admired and was awarded with 'Baruka Gold Medal'. He has also been awarded the prestigious 'O. P. Jindal Gold Medal' for outstanding contribution to the ferrous industry.

**Mr. Supriya Gupta**

Mr. S. Gupta B.A ( Hons.) CAIIB, aged about 69 years, is a retired bank executive of over 44 years experience. He served in the top management positions of State Bank of India and was the Chairman of UTI Bank Limited. Mr. Supriya Gupta has expertise in functional area like corporate business, banking, finance, accounting and regulatory matters. Mr. Gupta, formerly the president of the Calcutta Stock Exchange Association Limited, currently serves on the Board of Directors of many reputed companies and banks.

**Borrowing powers of Board of Directors**

Pursuant to a resolution dated July 22, 2005 passed by our shareholders in accordance with the provisions of the Companies Act, our Board has been authorised to borrow money for the purposes of the Company

upon such terms and conditions and with/without security as the Board of Directors may think fit, provided that the money or monies to be borrowed together with the monies already borrowed by the Company (apart from the temporary loans obtained from the Company's bankers in the ordinary course of business) shall not exceed, at any time, a sum of Rs. 100,000 lacs.

#### Details of Appointment and Compensation of our Directors

Name of Directors	Contract/Appointment Letter/ Resolution	Details of Remuneration	Term
Mr. Ghanshaymdas Agarwal	Subscriber to the memorandum	No remuneration is being paid other than sitting fees.	Liabile to retire by rotation
Mr. Jugal Kishore Agarwal	Subscriber to the memorandum	No remuneration is being paid other than sitting fees.	Liabile to retire by rotation
Mr. Mahesh Kumar Agarwal	Subscriber to the memorandum	No remuneration except sitting fees.	Liabile to retire by rotation
Mr. Manoj Kumar Agarwal	Subscriber to the memorandum. Appointed as Managing Director pursuant to resolution passed on March 15, 2004 and agreement dated March 16, 2004.	Up to Rs 283,333 per annum with effect from March 15, 2004 to March 14, 2009	Whole time director. Term as Managing Director is form March 15, 2004 to March 14, 2009.
Mr. Mohan Lal Agarwal	Board resolution dated September 15, 2003	No remuneration is being paid.	Liabile to retire by rotation
Mr. Nirmal Kumar Agarwal	Board resolution dated May 6, 2002	No remuneration is being paid.	Liabile to retire by rotation
Mr. L. M. Chatterjee	Board resolution dated December 19, 2005	No remuneration is being paid.	Liabile to retire by rotation
Mr. Supriya Gupta	Board resolution dated December 19, 2005	No remuneration is being paid.	Liabile to retire by rotation
Mr. Nihar Ranjan Hota	Board resolution dated December 19, 2005	No remuneration is being paid.	Liabile to retire by rotation

Except for our whole-time Directors who are entitled to statutory benefits upon termination of their employment with our Company, no other Director is entitled to any benefit upon termination of his employment with our Company.

#### Remuneration of whole time Directors

The following table sets forth the details of the remuneration for the whole time Directors for the fiscal year ended March 31, 2005 :

S.N.	Name	Basic Salary (per year) Rs.	Director's Sitting Fee Rs.	Total Rs.
1.	Mr. Manoj Kumar Agarwal	2,83,333	3,000	2,86,333

\* *Perquisites in the nature of medical reimbursement for self and family, leave travel concession for self and family, club fees, personal accident insurance.*

# *The remuneration of the managing director is proposed to be increased to Rs. 36 lacs. The Board has passed the requisite resolution on December 19, 2005 and the same is now subject to the approval of the shareholders.*

## **Details of employment contracts with our Directors**

*Employment agreement dated March 16, 2004 executed between Mr. Manoj Kumar Agarwal and our Company.*

Our Managing Director, Mr. Manoj Agarwal, was appointed pursuant to an employment agreement dated March 16, 2004 executed between Mr. Manoj Agarwal and the Company with effect from March 15, 2004.

### **A. Corporate Governance**

Our Company is in compliance of the provisions for corporate governance as stipulated in the listing agreements with the Stock Exchanges, including with respect to the appointment of independent Directors to our Board and the constitution of the audit committee, investor grievance committee and compensation committee.

We have constituted the following committees of our Board of Directors for compliance with corporate governance requirements:

- (a) Audit Committee;
- (b) Shareholders' / Investors' Grievance Committee;
- (c) Remuneration Committee;

#### *(a) Audit Committee*

The audit committee comprises of Mr. Supriya Gupta (Independent Director), Mr. L. M. Chatterjee (Independent Director), Mr. N. R. Hota (Independent Director), Mr. Manoj Kumar Agarwal (Managing Director). The audit committee was constituted to act in accordance with the provisions of the Companies Act, the listing agreements with the Stock Exchanges and the terms of reference specified in the resolution of the Board of Directors reconstituting the audit committee.

The terms of reference of the audit committee includes the following:

1. Overseeing of our financial reporting process and the disclosure of our financial information to ensure that the financial statement is correct, sufficient and credible;
2. Recommending the appointment and removal of external auditor, fixation of audit fee and also approval for payment for any other services;
3. Reviewing with the management the annual financial statements before submission to the Board;
4. Reviewing with the management, external and internal auditors, the adequacy of internal control systems;
5. Reviewing the adequacy of internal audit function, including the structure of the internal audit department, staffing and seniority of the official heading the department, reporting structure, coverage and frequency of internal audit;
6. Discussion with internal auditors any significant findings and follow up thereon;
7. Reviewing the findings of any internal investigations by the internal auditors into matters where there is suspected fraud or irregularity or a failure of internal control systems of a material nature and reporting the matter to the Board;
8. Discussion with external auditors before the audit commences, nature and scope of the audit, as well as have post audit discussion to ascertain any area of concern;
9. Reviewing our financial and risk management policies;
10. To look into the reason for substantial defaults in payments to depositors, debenture holders, shareholders (in case of non payment of declared dividends) and creditors.

#### *(b) Investor Grievance Committee*

This committee consists of Mr. L. M. Chatterjee (Independent Director) Mr. Ghanshaym Das Agarwal (Chairman) and Mr. Mahesh Kumar Agarwal (Director). This committee has been constituted for the purposes of addresses investor grievances and complaints in matters such as transfer of Equity Shares, non-receipt of balance sheet, non-receipt of declared dividends, etc.

*(c) Compensation Committee*

This committee consists of Mr. Supriya Gupta (Independent Director), Mr. L. M. Chatterjee (Independent Director), Mr. N. R. Hota (Independent Director). The Remuneration Committee has been set up to review the overall compensation structure and related policies of our Company with a view to attract, motivate and retain employees. The committee determines our Company's policies on remuneration packages payable to whole time/managing directors including performance bonus and perquisites and also reviews the compensation levels vis-à-vis other companies and the industry in general.

**Shareholding of our Directors in the Company as of January 9, 2006**

The following table details the shareholding of our Directors in their personal capacity and either as sole or first holder, as at the date of this Prospectus:

<b>Name of Directors</b>	<b>Number of Equity Shares (Pre-Issue)</b>
Mr. Jugal Kishore Agarwal	1,01,000
Mr. Ghanshyamdas Agarwal,	6,72,888
Mr. Nirmal Kumar Agarwal	12,60,500
Mr. Mohan Lal Agarwal	11,68,388
Mr. Mahesh Kumar Agarwal	9,22,410
Mr. Manoj Kumar Agarwal	9,60,366
Mr. L. M. Chatterjee	1,000
Mr. Supriya Gupta	Nil
Mr. Nihar Ranjan Hota	Nil

**Interest of Directors**

All of our Directors, including independent directors, may be deemed to be interested to the extent of fees, if any, payable to them for attending meetings of the Board or a committee thereof as well as to the extent of other remuneration and reimbursement of expenses payable to them under our Articles of Association. The executive Directors are interested to the extent of remuneration paid to them for services rendered as an officer or employee of our Company and the terms of such remuneration are set forth in contracts executed between our executive Directors and our Company.

All our Directors, including independent directors, may also be deemed to be interested to the extent of Equity Shares, if any, already held by them or that may be subscribed for and allotted to them, out of the present Issue in terms of the Prospectus and also to the extent of any dividend payable to them and other distributions in respect of the said Equity Shares. Our Directors, including independent directors, may also be regarded as interested in the Equity Shares, if any, held by or that may be subscribed by and allotted to the companies, firms and trust, in which they are interested as directors, members, partners or trustees.

Our Directors have no interest in any property in which the Company has an interest within two years of the date of filing of this Prospectus, except the following:

<b>Name of Director</b>	<b>Property Details</b>	
Mr. Jugal Kishore Agarwal	Land measuring about 3.96 acres situated at village Chadrihariharpur, Orissa	Given lease to the Company for a period of 15 years commencing from August 9, 2004
Mr. Nirmal Kumar Agarwal	Land measuring about 5.28 acres situated at village Chadrihariharpur, Orissa	Given lease to the Company for a period of 15 years commencing from August 9, 2004
Mr. Ghanshyamdas Agarwal	Land measuring about 6.55 acres situated at village Chadrihariharpur, Orissa	Given lease to the Company for a period of 15 years commencing from August 9, 2004

#### **Changes in Our Board of Directors during the last three years**

<b>Name</b>	<b>Date of Appointment</b>	<b>Date of Cessation</b>	<b>Reason</b>
Mr. Mohan Lal Agarwal	September 15, 2003	Continuing	Appointment as director
Mr. L. M. Chatterjee	December 19, 2005	Continuing	Appointed as Additional Director
Mr. N. R. Hota	December 19, 2005	Continuing	Appointed as Additional Director
Mr. Supriya Gupta	December 19, 2005	Continuing	Appointed as Additional Director

## Organization Chart

The organization structure of the senior management of our Company is given below:

### Organization Structure Chart

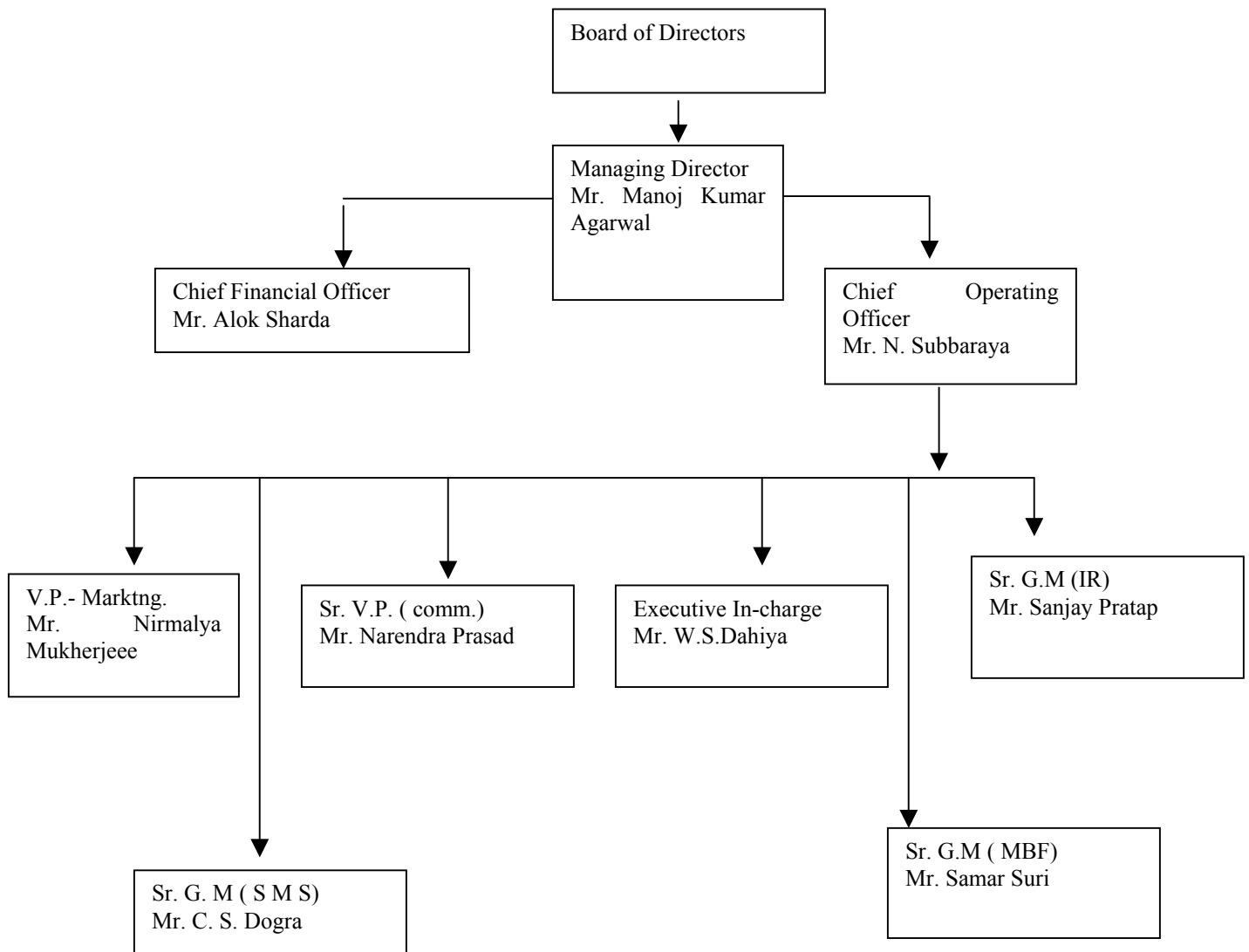

## Key Managerial Personnel

All of our key managerial personnel are a permanent employees of our Company and none of them are related to each other or to any Director of our Company.

### Family relation with the Key Managerial Personnel

Mr. M. K. Agarwal, Managing Director is the promoter Director. Apart from him no other is related to the promoters/ Director of the company.

The details of our key managerial personnel are as follows:

Name	Age	Designation	Qualifications	Previous Employment	Total Experience	
N.Subbaraya	58	Chief Operating Officer	B.E. (Elect.)	1. SAIL 2. Nagarjuna Steels Limited 3. Windson Engineers 4. Bharat Strips Limited 5. Midwest Iron & Steel Co. Limited 6. Lanco Industries Limited 7. Cauvery Grinding & Mfg (Co.) Limited	36 Years	13 <sup>th</sup> June 2005
Narendra Prasad	47	Sr. V.P. (Commercial & Supply Chain)	FCA.	1. Usha Martin Limited 2. NELCO Limited 3. Bihar Alloys & Steels Limited 4. Rajendra Steels Limited 5. Llyods Metals Limited	20 Years	1 <sup>st</sup> July 2005
Nirmalya Mukherjee	43	VP (Marketing & Quality)	B.E., M.Tech	1. SAIL 2. Usha Martin Industries.	19 Years	12 <sup>th</sup> August 2005
Sanjay Pratap	42	Sr. GM (IR)	B.A., L.L.B	Tata Metaliks Limited	15 years	1 <sup>st</sup> January 2004
Samar Suri	38	Senior G.M. (MBF)	B.E.	1. Tata Metaliks Limited 2. Jindal Steel & Power Limited	12 Years	21 <sup>st</sup> December, 2003
W. S. Dahiya	50	Executive in charge	Diploma in Mechanical Engineering.	1. Surya Roshni Limited 2. Hindustan Wires Limited	23 years	15 <sup>th</sup> February, 2005
C. S. Dogra	39	Senior G.M. (SMS)	B. E	Usha Martin Limited	12 years	10 <sup>th</sup> March, 2004
Alok Sharda	37	Chief Financial Officer	FCA, AICWA	Usha Martin Limited VISA Limited	15 Years	21 <sup>st</sup> September 2005
Sougata Sengupta	31	Company Secretary	B. Com ( Hons.), A.C.S.	Webel SL Energy Systems Limited	8 Years	March 10, 2004

## **Brief Biography of Key Managerial Personnel:**

### **Mr. N. Subbaraya**

Mr. Subbaraya is a electrical engineer with 36 years of working experience with various corporates. He started his career in 1969 with Steel Authority Of India Limited and in 1987 he joined Nagarjuna Steels Limited, Hyderabad as works incharge thereafter he shifted in 1989 and joined Bharat Strips Ltd, Hydrabad as Vice President. From 1990 to 1997 he worked as president in Mideast Iron & steel co. Limited, Hyderabad and in 1997 he joined as chief executive officer in Lanco Industries Ltd, Tirupati. He joined Adhunik Metaliks Limited on June 13, 2005 as the chief operating officer. He is the overall incharge of the entire complex covering all aspects of management for running units, projects & developments.

### **Mr. Narendra Prasad**

Mr. Prasad is a Chartered Accountant (FCA) with 20 years of working experience with various reputed corporate houses like Usha Martin Limited where he worked as a manager commercial from 1985 to 1990, thereafter he joined NELCO Ltd as manager finance from 1990 to 1992, after which he worked in Bihar Alloy & Steels Limited as senior manager - purchase from 1992 to 1994, then with Rajendra Steels Ltd as deputy general manager – commercial from 1994 to 1996, and in Lloyds Metals Ltd as general manager-commercial from 1996 to 1997. In 1997 he again joined Usha Martin Limited as general manager-commercial whereafter he joined our Company on July 1, 2005 as senior vice president (commercial & supply chain). He is the incharge of purchase, stores, accounts, logistics, insurance and material handling.

### **Mr. Nirmalya Mukherjee**

Mr. Mukherjee is a BE, M. Tech. He was associated with Usha Martin Limited for the last 18 years and left Usha Martin Limited in the capacity of general manager. He joined our Company as vice president (marketing & quality).

### **Mr. Sanjay Pratap**

Mr. Pratap is a BA, LLB from a reputed University. In the last 15 years he handled various legal and government related matters on behalf of various reputed organisation like Tata Metalliks Limited etc. He is the senior general manager (industrial relation) of our Company.

### **Mr. Samar Suri**

Mr. Suri is a bachelor of engineering from a reputed University. In the last 12 years he worked in MBF project and operation maintenance in various reputed organisation like Tata Metaliks Limited, Jindal Steel & Power Limited etc. He joined our Company on 21st December 2003 as senior general Manager (MBF). He is the overall incharge of the MBF division covering all aspects of management for running MBF division.

### **Mr. Alok Sharda**

Mr. Sharda has a varied experience in the field of finance and accounts. He is an associate member of the Institute of Chartered Accounts of India. He started his professional career with Hindalco Limited. After working in Hindalco for three years he worked for more than a decade with Usha Martin Limited and VISA Steel Limited. He joined the Company on September 21, 2005.

### **Mr. Sougata Sengupta**

Mr. Sengupta is an associate member of the Institute of Company Secretaries of India. He has more than 8 years of working experience in corporate laws and other legal matters. He worked in Webel SL Energy Systems Limited as a company secretary prior to joining the Company on March 8, 2004.

## **Shareholding of our key managerial personnel in our Company as of September 30, 2005**

None of our key managerial personnel hold any Equity Shares of our Company.

## **Bonus or profit sharing plan for the Key Managerial Personnel**

There is no profit sharing plan for the key managerial personnel.

## **Changes in our key managerial employees during the last three years**

<b>Name</b>	<b>Designation</b>	<b>Date of Joining</b>	<b>Date of Resignation</b>	<b>Reason</b>
N. Subba Raya	Chief Operating Officer	June 13, 2005	Nil	NA
Narendra Prasad	Sr. Vice President (Commercial & Supply Chain)	July 1, 2005	Nil	NA
Nirmalya Mukherjee	Vice President (Marketing & Quality)	August 12, 2005	Nil	NA
Sanjay Pratap	Sr.General Manager( Industrial Relation)	January 1, 2004	Nil	NA
Samar Suri	Senior General Manager (MBF)	December 21, 2003	Nil	NA
Alok Sarda	Chief Financial Officer	September 21, 2005	Nil	NA
Sougata Sengupta	Company Secretary	March 10, 2004	Nil	NA

#### **Employees Stock Option Scheme/ Employees Stock Purchase Scheme**

The Company has not introduced any Employees Stock Option Scheme/ Employees Stock Purchase Scheme, in terms of the guidelines or regulations of SEBI relating to Employees Stock Option Scheme and Employee Stock Purchase Scheme.

#### **Payment or benefit to the officers of the Company**

Except the payment of salaries and perquisites, the Company also pay ex-gratia payments to its officers as and when it deems fit. Except statutory benefits upon termination of their employment in our Company or superannuation, no officer of our Company is entitled to any benefit upon termination of his employment in our Company or superannuation.

#### **Interest of Promoters and key managerial personnel**

Except as stated in “Related Party Transactions” on page 162 of this Prospectus, and to the extent of shareholding in the Company, the Promoters and promoter group do not have any other interest in company’s business.

The key managerial personnel of the Company does not have any interest in the Company other than to the extent of the remuneration or benefits to which he is entitled to as per their terms of appointment and reimbursement of expenses incurred by him during the ordinary course of business and to the extent of the Equity Shares held by him in the Company, if any.

#### **Details of loans taken by key managerial personnel in our Company**

Our Directors and our key managerial personnel have not taken any loan from our Company.

## OUR PROMOTER AND GROUP COMPANIES

### Our Promoters

The Promoters of our Company are six natural persons, two companies.

The natural persons who are our Promoters are:

1. Mr. Jugal Kishore Agarwal,
2. Mr. Ghanshyamdas Agarwal,
3. Mr. Nirmal Kumar Agarwal,
4. Mr. Mohan Lal Agarwal,
5. Mr. Mahesh Kumar Agarwal,
6. Mr. Manoj Kumar Agarwal,

The companies which are our Promoter :

1. Sungrowth Shares and Stocks Limited and
2. Mahananda Suppliers Limited

The details of our Promoters are as follows:

#### Mr. Jugal Kishore Agarwal



Mr. J. K. Agarwal 54 years, (Passport Number: A6492597, Voter ID Number: not available, Driving License Number: not available) is a law graduate from Calcutta University. He has almost 3 decades of experience in the steel sector in the area of trading and providing services to other manufacturing units in this segment. Mr. Agarwal has been a guiding force behind the Group and has played a key role in envisioning the various business initiatives of the group. He possesses expertise in financial matters and has been an important contributor in all the financial matters of the group.

#### Mr. Ghanshyamdas Agarwal



Mr. G. D. Agarwal 48 years (Passport Number: A8741278, Voter ID Number: not available, Driving License Number: not available) is a commerce graduate from Calcutta University. He has over 2 decades of experience in the steel sector in the area of trading and providing services to other manufacturing units in this segment. Mr. Agarwal pioneered the investment of the Group into ferro alloys by setting up a plant in Meghalaya under the name and style of Adhunik Meghalaya Steels (P) Limited As the chairman of the Company he has been instrumental in defining the investment plans of the Company.

#### **Mr. Nirmal Kumar Agarwal**



Mr. N.K. Agarwal 43 years, (Passport Number: A4904827, Voter ID Number: not available, Driving License Number: not available) is a science graduate. He has about 2 decades of experience in the steel sector and has been mainly involved in the trading activity of the Group. Under his able guidance the Group started operations in Mandi Gobindgarh, Punjab the hub of steel trading in India. Mr. Agarwal is keenly involved with various Industrial Associations and is currently the regional director of Sponge Iron Manufacturers of India.

#### **Mr. Mohan Lal Agarwal**



Mr. Mohan Lal Agarwal 40 years, (Pan number:ACUPA7179F, Passport number: not available, Voter ID Number: not available, Driving License Number: not available) is a commerce graduate from Calcutta University. He has more than 15 years of experience in the steel sector in the area of trading and providing services to other manufacturing units in this segment and is responsible for the day-to-day management of the plant.

#### **Mr. Mahesh Kumar Agarwal**



Mr. M. K. Agarwal 39 years, (Passport Number: E4907553, Voter ID Number: not available, Driving License Number: not available) is a commerce graduate from Calcutta University. He has over 14 years of experience in the steel sector in the area of trading and providing services to other manufacturing units in this segment. Mr. Mahesh Kumar Agarwal has hands on experience in all the accounting and financials of the Company, he has been the front-runner in terms of project execution in West Bengal and is accredited for setting up the first sponge iron plant and rolling mill of the Group in the year 2001. He is the managing director of Adhunik Corporation Limited.

#### **Mr. Manoj Kumar Agarwal**



Mr. M. K. Agarwal 36 years, (Passport Number: P511524, Voter ID Number: not available, Driving License Number: 673/99) our Managing Director and one of our Promoters, is a graduate in engineering from REC Kurukshetra. He has more than a decade of experience in the steel industry in the area of trading and providing services to other manufacturing units in this segment. Mr. M.K. Agarwal has not only visualised the road map of growth for the group but has also taken on himself to implement the projects in record time. Under his able leadership our Company has witnessed significant growth both in terms of setting up competitive manufacturing facilities and profitability. Mr. M.K. Agarwal is an experienced entrepreneur and has had a major influence in shaping up the future operations of the group. Under his leadership the Company has been able to convince the State Government of Orissa to enter into a memorandum of understanding and recommend the mining leases for coal and iron ore.

We confirm that the permanent account numbers, bank account numbers and passport numbers of Mr. Jugal Kishore Agarwal, Mr. Ghanshyamdas Agarwal, Mr. Nirmal Kumar Agarwal, Mr. Mahesh Kumar Agarwal and Mr. Manoj Kumar Agarwal will be submitted to the Stock Exchanges at the time of filing the Prospectus with the Stock Exchanges. The permanent account number and bank account number of Mr. Mohan Lal Agarwal will be submitted to the Stock Exchanges at the time of filing the Prospectus with the Stock Exchanges.

### **Sungrowth Shares and Stocks Limited**

Sungrowth Shares and Stocks Limited (“SSSL”) was incorporated on November 30, 1994 as a non banking finance company and has its registered office at 25D, Harish Mukherjee Road, 1E, 1<sup>st</sup> Floor, Kolkata- 700 025. Its promoters are Mr. Jugal Kishore Agarwal, Mr. Ghanshyamdas Agarwal, Mr. Mohan Lal Agarwal, Mr. Nirmal Kumar Agarwal, Mr. Mahesh Kumar Agarwal and Mr. Manoj Kumar Agarwal. The main business is to invest in equity share capital of various companies. As on the date of filing of the Prospectus, SSSL as a Promoter of our Company holds 35.85% of the shareholding of our Company.

#### ***Shareholding Pattern:***

The equity shares of SSSL are not listed on any stock exchange. The shareholding pattern of SSSL, as on the date of filing of this Prospectus, is as given below:

<b>Sl. No.</b>	<b>Name of Shareholder</b>	<b>Number of Shares</b>	<b>% of Issued Capital</b>
1	Mr. Jugal Kishore Agarwal	376,000	11.79
2	Mr. Ghanshyamdas Agarwal	344,980	10.82
3	Mr. Nirmal Kumar Agarwal	367,780	11.53
4	Mr. Mohanlal Agarwal	371,000	11.63
5	Mr. Mahesh Kumar Agarwal	371,750	11.65
6	Mr. Manoj Kumar Agarwal	343,500	10.77
7	Murli Management Limited	568,910	17.84
8	Manohar Management Limited	445,850	13.98
<b>TOTAL</b>		<b>3,189,770</b>	<b>100.00</b>

#### ***Board of Directors:***

The present board of directors of SSSL comprises of:

<b>Name of the Director</b>	<b>Date of appointment</b>
Mr. Jugal Kishore Agarwal	September 1, 2003
Mr. Ghanshyamdas Agarwal	July 28, 2003
Mr. Nirmal Kumar Agarwal	September 1, 2003
Mr. Mohanlal Agarwal	July 28, 2003
Mr. Mahesh Kumar Agarwal	July 28, 2003
Mr. Manoj Kumar Agarwal	September 1, 2003

#### ***Change in management***

S.N.	Name of director	Date of appointment / change	Particulars of change
1.	Banwari Lal Mittal	September 4, 2002	Appointed as an additional director.
2.	Ravi Kant Sharma	September 4, 2002	Appointed as an additional director.
3.	Vimal Kumar Lahoti	September 4, 2002	Appointed as an additional director.
4.	Bela Rani Poddar	September 10, 2002	Resigned from directorship
5.	Rupa Agarwal	September 10, 2002	Resigned from directorship
6.	Sova Agarwal	September 10, 2002	Resigned from directorship
7.	Ghanshyamdas Agarwal	July 28, 2003	Appointed as an additional director.
8.	Mahesh Kumar Agarwal	July 28, 2003	Appointed as an additional director.
9.	Mohan Lal Agarwal	July 28, 2003	Appointed as an additional director.
10.	Ravi Kant Sharma	July 28, 2003	Resigned from directorship
11.	Vimal Kumar Lahoti	July 28, 2003	Resigned from directorship
12.	Jugal Kishore Agarwal	September 1, 2003	Appointed as additional director.
13.	Nirmal Kumar Agarwal	September 1, 2003	Appointed as additional director.
14.	Manoj Kumar Agarwal	September 1, 2003	Appointed as additional director.
15.	Banwari Lal Mittal	April 1, 2004	Resigned from directorship

***Details of persons holding controlling interest***

Mr. Jugal Kishore Agarwal, Mr. Ghanshyamdas Agarwal, Mr. Mohan Lal Agarwal, Mr. Nirmal Kumar Agarwal, Mr. Mahesh Kumar Agarwal and Mr. Manoj Kumar Agarwal. For details of the aforesaid persons please refer to the section titled Our Promoters on page 121 of this Prospectus.

***Financial Performance:***

The financial results of SSSL for the years ended March 31, 2003, 2004 and 2005 are set forth below:

*(Rs. in Lacs, except per share data)*

Particulars	For the year ended March 31		
	2003	2004	2005
Sales	37.66	1563.61	263.87
Other Income	2.78	9.34	0.09
PBIDT	0.19	0.20	(0.11)
PBT	0.19	0.20	(0.11)
PAT	0.10	0.11	(.07)
Share Capital	214.75	227.00	318.98
Reserves & Surplus	1573.92	1684.12	3431.21
Net Worth	1788.62	1911.09	3750.19
EPS (Rs.)	0.01	0.01	Nil
NAV	83.29	84.19	117.56
Debt Equity Ratio	Nil	Nil	Nil
Dividend	Nil	Nil	Nil

## SSSL's PAN, Bank Account Details, Company Registration Number and Address of ROC

SSSL has confirmed the following details:

<b>Permanent Account Number</b>	AAECS3913P
<b>Bankers name and address</b>	ABN Amro Bank, 7 Camac Street, Kolkata-700 017.
	Current Account No. 848116
<b>Company Registration Number</b>	21-66223
<b>MAPIN</b>	
<b>Address of ROC</b>	234/4 AJC Bose Road, 2 <sup>nd</sup> Floor, Nizam Palace, 2 <sup>nd</sup> MSO Bldg. Kolkata 700 020
<b>RBI Registration Number</b>	

SSSL has further confirmed the above will be submitted to the Stock Exchanges at the time of filing the Prospectus with them. Further, SSSL has confirmed that it is not detained as willful defaulters by the Reserve Bank of India or any other governmental authority and there are no violations of securities laws committed by them in the past or are pending against them.

### Payment of benefits to SSSL within the last two years

No payment or benefits have been received by SSSL from the Company in the last two years.

### Mahananda Suppliers Limited

Mahananda Suppliers Limited (“MSL”) was incorporated on April 6, 1995 as a non banking finance company and has its registered office at 25D, Harish Mukherjee Road, 1E, 1<sup>st</sup> Floor, Kolkata- 700 025. Its promoters are Mr. Jugal Kishore Agarwal, Mr. Ghanshyamdas Agarwal, Mr. Mohan Lal Agarwal, Mr. Nirmal Kumar Agarwal, Mr. Mahesh Kumar Agarwal and Mr. Manoj Kumar Agarwal.. The main business of MSL is to invest in equity share capital of various companies. As on the date of filing of the Prospectus, MSL as a Promoter of our Company holds 22.58% of the shareholding of our Company.

#### *Shareholding Pattern:*

The equity shares of MSL are not listed on any stock exchange. The shareholding pattern of MSL as on the date of filing of this Prospectus, is as given below:

<b>Sl. No.</b>	<b>Name of Shareholder</b>	<b>Number of Shares</b>	<b>% of Issued Capital</b>
1	Mr. Jugal Kishore Agarwal	1115000	16.63
2	Mr. Ghanshyamdas Agarwal	1115000	16.63
3	Mr. Nirmal Kumar Agarwal	1115000	16.63
4	Mr. Mohanlal Agarwal	1129303	16.84
5	Mr. Mahesh Kumar Agarwal	1115000	16.63
6	Mr. Manoj Kumar Agarwal	1115000	16.63
<b>TOTAL</b>		<b>6704303</b>	<b>100.00</b>

#### *Board of Directors:*

The present board of directors of MSL comprises of:

<b>Name of the Director</b>	<b>Date of appointment</b>
Mr. Jugal Kishore Agarwal	December 20, 2004
Mr. Ghanshyamdas Agarwal	December 20, 2004
Mr. Nirmal Kumar Agarwal	December 20, 2004
Mr. Mohanlal Agarwal	December 20, 2004
Mr. Mahesh Kumar Agarwal	December 20, 2004
Mr. Manoj Kumar Agarwal	December 20, 2004
Ranjeet Dutta	January 2, 2004

*Change in management*

<b>S.N.</b>	<b>Name of director</b>	<b>Date of appointment / change</b>	<b>Particulars of change</b>
1.	Banwari Lal Mittal	April 14, 2003	Appointed as additional director.
2.	Sandeep Sharma	April 14, 2003	Appointed as additional director.
3.	Sanjay Agarwal	August 25, 2003	Resigned from directorship
4.	Vinita Agarwal	August 25, 2003	Resigned from directorship
5.	Rajiv Sharma	January 2, 2004	Appointed as additional director
6.	Ranjeet Dutta	January 2, 2004	Appointed as additional director
7.	Banwari Lal Mittal	January 2, 2004	Resigned form directorship
8.	Jugal Kishore Agarwal	December 20, 2004	Appointed as director
9.	Ghanshyamdas Agarwal	December 20, 2004	Appointed as director
10.	Nirmal Kumar Agarwal	December 20, 2004	Appointed as director
11.	Mahesh Kumar Agarwal	December 20, 2004	Appointed as director
12.	Manoj Kumar Agarwal	December 20, 2004	Appointed as director
13.	Mohan Lal Agarwal	December 20, 2004	Appointed as director
14.	Rajiv Sharma	December 20, 2004	Resigned from directorship
15.	Sandeep Sharma	December 20, 2004	Resigned from directorship

*Details of persons holding controlling interest*

Mr. Jugal Kishore Agarwal, Mr. Ghanshyamdas Agarwal, Mr. Mohan Lal Agarwal, Mr. Nirmal Kumar Agarwal, Mr. Mahesh Kumar Agarwal and Mr. Manoj Kumar Agarwal. For details of the aforesaid persons please refer to the section titled Our Promoters on page 121 of this Prospectus.

*Financial Performance:*

The financial results of MSL for the years ended March 31, 2003, 2004 and 2005 are set forth below:

(Rs. in Lacs, except per share data)

Particulars	For the year ended March 31		
	2003	2004	2005
Sales	24.00	83.05	1959.06
Other Income		12.90	62.20
PBIDT	(0.29)	9.88	55.27
PBT	(0.29)	1.19	10.62
PAT	(0.29)	0.67	6.90
Share Capital	35.17	198.02	670.43
Reserves & Surplus	58.80	1523.17	5778.70
Net Worth	93.97	1721.16	6449.13
EPS (Rs.)		0.03	0.10
NAV	26.70	86.92	96.19
Debt Equity Ratio		-	-
Dividend	-	-	-

#### MSL'S PAN, Bank Account Details, Company Registration Number and Address of ROC

MSL has confirmed the following details:

<b>Permanent Account Number</b>	AABCM8069K
<b>Bankers name and address</b>	ABN Amro Bank, 7 Camac Street, Kolkata-700 017.
<b>Bank Account Number</b>	Current Account No. 852631
	21-70966
<b>MAPIN</b>	100194381
<b>Address of ROC</b>	234/4 AJC Bose Road, 2 <sup>nd</sup> Floor, Nizam Palace, 2 <sup>nd</sup> MSO Bldg. Kolkata 700 020
<b>RBI Registration Number</b>	B.05.03724

MSL has further confirmed the above will be submitted to the Stock Exchanges at the time of filing the Prospectus with them. Further, MSL has confirmed that it is not detained as willful defaulters by the Reserve Bank of India or any other governmental authority and there are no violations of securities laws committed by them in the past or are pending against them.

#### Payment of benefits to MSL within the last two years

No payment or benefits have been received by MSL from the Company in the last two years.

#### Promoter Group

The individuals included in our Promoter Group are:

1. Ramadevi Agarwal
2. Premila Agarwal

3. Meena
4. Rita Agarwal
5. Chandrakanta Agarwal
6. Sonika Agarwal
7. Naveen Agarwal
8. Subha Agarwal
9. Aakaransh Agarwal
10. Chirag Agarwal
11. Vaibhav Agarwal
12. Malvika Agarwal
13. Sachin Agarwal
14. Puja Agarwal
15. Akriti Agarwal
16. Aakansha Agarwal
17. Mayank Agarwal
18. Rachit Agarwal
19. Ruchika Agarwal
20. Harsh Agarwal

The companies, partnerships firms, proprietorship firms in our Promoter Group are:

1. Adhunik Corporation Limited
2. Adhunik Ispat Limited
3. Adhunik Alloys & Power Limited
4. Adhunik Meghalaya Steels Private Limited
5. Adhunik Steel Limited.
6. Neepaz Tube Private Limited;
7. Futuristic Steel Private Limited.
8. Sri. M. P. Ispat Private Limited.
9. Swarnrekha Steel Industries.
10. Shivalik Transport.
11. Adhunik Thermal Energy Limited.
12. Adhunik Metcoke Pvt. Limited.
13. Manohar Management Limited
14. Adhunik Infotech Limited.

The details of the companies, partnerships firms, proprietorship firms in our Promoter Group are as follows:

### **1. Adhunik Corporation Limited**

Adhunik Corporation Limited (“ACL”) was incorporated on February 2, 1996. ACL is in the activity of manufacturing sponge iron and alloy steel billets. Its promoters are Mr. Jugal Kishore Agarwal, Mr. Ghanshyamdas Agarwal, Mr. Mohan Lal Agarwal, Mr. Nirmal Kumar Agarwal, Mr. Mahesh Kumar Agarwal and Mr. Manoj Kumar Agarwal.

#### *Shareholding Pattern*

The equity shares of ACL are not listed on any stock exchange. The shareholding pattern of ACL, as on the date of filing of this Prospectus, is as given below:

<b>Sl.</b>	<b>Name of Shareholder</b>	<b>Number of Shares</b>	<b>% of Issued</b>
------------	----------------------------	-------------------------	--------------------

No.			Capital
1.	Sungrowth Share & Stocks Limited	7,650,739	29.24
2.	Neepaz Steels (India) Ltd	4,349,352	16.62
3.	Adhunik Steels Limited	2,665,913	9.81
4.	Adhunik Ferro Alloys Limited	1,983,891	7.58
5.	Mohan Lal Agarwal	1,222,780	4.67
6.	Suvarnapuspa Investment Private Limited	977,885	3.74
7.	Ghanshyam Das Agarwal	933,913	3.57
8.	Mahesh Kumar Agarwal	836,413	3.20
9.	Nirmal Kumar Agarwal	832,282	3.18
10.	Meena Agarwal	812,430	3.11
11.	Others	3,999,567	15.29
<b>TOTAL</b>		<b>206,165,165</b>	<b>100.00</b>

#### Directors

The board of directors of ACL comprises of:

1. Mr. Ghanshyam Das Agarwal
2. Mr. Mohanlal Agarwal
3. Mr. Mahesh Kumar Agarwal
4. Mrs. Meena Agarwal
5. Mr. Nirmal Kumar Agarwal
6. Mr. Manoj Kumar Agarwal

#### Financial Performance

The unconsolidated financial results for ACL for fiscal 2003, fiscal 2004 and fiscal 2005 are as follows:

*(Rs. in lacs except share data)*

Particulars	For the year ended March 31		
	2003	2004	2005
Sales	7234.78	14968.22	22195.23
Other Income	2.83	10.18	18.70
PBIDT	673.89	997.23	1103.17
PBT	400.96	553.43	621.29
PAT	253.61	354.15	403.56
Share Capital	1085.87	1345.72	2616.52
Reserves & Surplus*	372.50	726.65	1981.41
Net Worth	1827.49	2785.68	4604.74
EPS (Rs.)	2.34	2.63	1.54
NAV	16.83	20.70	17.60
Debt Equity Ratio	0.97	0.66	0.40
Dividend	Nil	Nil	Nil

\* excluding revaluation reserve

### ***Promise v/s Performance***

ACL is unlisted and has not made any public issues in the past.

### ***Changes in capital structure***

There has been no change in the capital structure of in the last six months.

### ***Details of public issue/ rights issue of capital in the last three years***

There have been no public issue of equity shares or rights issue in the three years preceding the date of this Prospectus.

## **2. Adhunik Ispat Limited**

Adhunik Ispat Limited (“**AIL**”) was incorporated on May 28, 2002 as a private limited company. The company was converted to a public limited company on May 19, 2005. AIL is primarily involved in the manufacture of rolled products. Its promoters are Mr. Jugal Kishore Agarwal, Mr. Ghanshyamdas Agarwal, Mr. Mohan Lal Agarwal, Mr. Nirmal Kumar Agarwal, Mr. Mahesh Kumar Agarwal and Mr. Manoj Kumar Agarwal.

### ***Shareholding Pattern:***

The equity shares of AIL are not listed on any stock exchange. The shareholding pattern of AIL, as on the date of filing of this Prospectus, is as given below:

<b>Sl. No.</b>	<b>Name of Shareholder</b>		<b>% of Issued Capital</b>
1.	Mahananda Suppliers Limited	5,070,000	36.29
2.	Murli Management Limited	2,235,000	16.00
3.	Manohar Management Limited	2,000,000	14.32
4.	Frankross Vinimay Private Limited	1,570,000	11.24
5.	Suvarnapusha Investment (P) Limited	1,418,500	10.15
6.	Sungrowth Stocks & Shares Limited	300,000	2.15
7.	Nirmal Kumar Agarwal	216,000	1.55
8.	Jugal Kishore	173,000	1.24
9.	Manoj Kumar Agarwal	102,720	0.74
10.	Deevee Commercials Limited	100,000	0.72
11.	Others	783,900	5.60
<b>TOTAL</b>		<b>13,969,120</b>	<b>100.00</b>

### ***Directors***

The board of directors of AIL comprises of:

1. Mr. Jugal Kishore Agarwal
2. Mr. Manoj Kumar Agarwal
3. Mr. Mahesh Kumar Agarwal
4. Mrs. Chandrakanta Agarwal
5. Mrs. Anita Agarwal

### **Financial Performance**

The unconsolidated financial results for AIL for fiscal 2003, fiscal 2004 and fiscal 2005 are as follows:

*(Rs. in Lacs except share data)*

Particulars	For the year ended March 31		
	2003	2004	2005
Sales	0.96	-	7363.26
Other Income	-	0.98	155.66
PBIDT	0.04	0.04	519.69
PBT	0.04	0.04	347.84
PAT	0.03	0.03	203.31
Share Capital	175	600	1396.91
Reserves & Surplus	0.03	0.05	509.36
Net Worth	668.76	763.37	2202.64
EPS (Rs.)	0.00	0.00	1.46
NAV	38.20	12.70	15.76
Debt Equity Ratio	0.20	0.90	1.33
Dividend	-	-	-

### **Promise v/s Performance**

The company is unlisted and there has been no public issues in the past. We are therefore not required to furnish details of promise v/s performance.

### **Changes in capital structure**

There has been no change in the capital structure of in the last six months.

### **Details of public issue/ rights issue of capital in the last three years**

There have been no public issue of equity shares or rights issue in the three years preceding the date of this Prospectus.

### **3. Adhunik Alloys & Power Limited.**

Adhunik Alloys & Power Limited (“AAPL”) was incorporated on July 22, 2003 and the date of commencement of production was on July 18, 2005. AAPL is involved in the business of manufacture of sponge iron. Its promoters are Mr. Jugal Kishore Agarwal, Mr. Ghanshyamdas Agarwal, Mr. Mohan Lal Agarwal, Mr. Nirmal Kumar Agarwal, Mr. Mahesh Kumar Agarwal and Mr. Manoj Kumar Agarwal and Mahananda Suppliers Limited.

### **Shareholding Pattern:**

The equity shares of AAPL are not listed on any stock exchange. The shareholding pattern of as on the date of filing of this Prospectus, is as follows:

Sl. No.	Name of Shareholder	Number of Shares	% of Issued Capital
1.	Mahananda Suppliers Limited	8,600,000	54.35
2.	Sungrowth Stocks & Shares Limited	2,958,800	18.70
3.	Murli Management Limited	1,350,000	8.53
4.	Information Synergies Private Limited	1,100,000	6.32

5.	Manohar Management Limited	500,000	3.16
6.	Sumantha Trading & Commission Private Limited	300,000	1.90
7.	Chowdhury Consultants Limited	150,000	0.95
8.	Sukhvarsha Distributors Private Limited	150,000	0.95
9.	Suvarnapusha Investment (P) Limited	100,000	0.63
10.	Naveen Kumar Agarwal (HUF)	95,000	0.60
11.	Others	519,200	3.91
<b>TOTAL</b>		<b>15,823,000</b>	<b>100.00</b>

### **Directors**

The board of directors of AAPL comprises of:

1. Mr. Ghanshyamdas Agarwal
2. Mr. Jugal Kishore Agarwal
3. Mr. Nirmal Kumar Agarwal
4. Mr. Mahesh Kumar Agarwal
5. Mr. Manoj Kumar Agarwal

### **Financial Performance**

The unconsolidated financial results for AAPL for fiscal 2004 and fiscal 2005 are as follows:

*(Rs. in Lacs except share data)*

Particulars	For the year ended March 31 <sup>st</sup>	
	2004	2005
Sales	-	-
Other Income	0.95	0.22
PBIDT	0.07	0.22
PBT	0.07	0.22
PAT	0.04	0.14
Share Capital	47.52	1524.30
Reserves & Surplus	0.04	417.30
Net Worth	109.53	1966.64
EPS (Rs.)	0.00	0.00
NAV	23.05	12.90
Debt Equity Ratio	-	1.76
Dividend	-	-

### **Promise v/s Performance**

The company is unlisted and there has been no public issues in the past. We are therefore not required to furnish details of promise v/s performance.

### **Changes in capital structure**

There has been no change in the capital structure of in the last six months.

### **Details of public issue/ rights issue of capital in the last three years**

There have been no public issue of equity shares or rights issue in the three years preceding the date of this Prospectus.

#### 4. Adhunik Meghalaya Steels Private Limited

Adhunik Meghalaya Steels Private Limited (“AMSPL”) was incorporated on November 14 , 2000. AAPL is involved in the business of manufacture of ferro alloys, ferro silicon and silico manganese. Its promoters are Mr. Jugal Kishore Agarwal, Mr. Ghanshyamdas Agarwal, Mr. Mohan Lal Agarwal, Mr. Nirmal Kumar Agarwal, Mr. Mahesh Kumar Agarwal and Mr. Manoj Kumar Agarwal.

##### **Shareholding Pattern:**

The equity shares of AMSPL are not listed on any stock exchange. The shareholding pattern of AMSPL as on the date of filing of this Prospectus, is as follows:

Sl. No.	Name of Shareholder	Number of Shares	% of Issued Capital
1.	Manohar Management Limited	2,370,000	32.51
2.	Murli Management Limited	2,095,000	28.74
3.	Sungrowth Stocks & Shares Limited	1,076,000	14.76
4.	Adhunik Steels Limited	614,200	8.43
5.	Futuristic Steel Private Limited	190,000	2.61
6.	Adhunik Ferro Alloys Limited	154,700	2.12
7.	Mahananda Suppliers Limited	150,000	2.06
8	Ghanshaym Das Agarwal	101,100	1.39
9	Mohan Lal Agarwal	101,100	1.39
10	Mahesh Kumar Agarwal	101,100	1.39
11	Others	336,600	4.60
<b>TOTAL</b>		<b>7,289,800</b>	<b>100.00</b>

##### *Directors*

The board of directors of AMSPL comprises of:

1. Mr.Ghanshyam Das Agarwal
2. Mr.Mohanlal Agarwal
3. Mr.Mahesh Kumar Agarwal
4. Mr.Manoj Kumar Agarwal
5. Mr. Nirmal Kumar Agarwal
6. Mr. Jugal Kishore Agarwal
7. Mr. Groth William Longwa

##### **Financial Performance**

The unconsolidated financial results for AMSPL for fiscal 2003, fiscal 2004 and fiscal 2005 are as follows:

*(Rs. in Lacs except share data)*

Particulars	For the year ended March 31		
	2003	2004	2005
Sales	510.06	2222.53	2219.94
Other Income	17.56	115.80	179.94
PBIDT	156.02	735.41	525.55
PBT	71.85	415.44	169.22
PAT	59.44	342.09	161.27
Share Capital	728.98	728.98	728.98
Reserves & Surplus	161.94	760.49	1118.60

Net Worth	915.94	1515.49	1874.59
EPS (Rs.)	0.82	4.69	2.21
NAV	12.56	20.79	25.72
Debt Equity Ratio	1.30	0.67	0.63
Dividend	-	-	-

### ***Promise v/s Performance***

The company is unlisted and there has been no public issues in the past. We are therefore not required to furnish details of promise v/s performance.

### ***Changes in capital structure***

There has been no change in the capital structure of in the last six months.

### ***Details of public issue/ rights issue of capital in the last three years***

There have been no public issue of equity shares or rights issue in the three years preceding the date of this Prospectus.

## **5. Adhunik Steel Limited**

Adhunik Steel Limited (“ASL”) was incorporated on May 20, 1992. ASL is involved in the business of manufacturing Primary products and Steel Ingots consisting of M.S., High Carbon Steel, Stainless Steel, and other Alloy Steels processing of steel products and trading of iron & steel items and ferro alloys. Its promoters are Mr. Jugal Kishore Agarwal, Mr. Ghanshyamdas Agarwal, Mr. Mohan Lal Agarwal, Mr. Nirmal Kumar Agarwal, Mr. Mahesh Kumar Agarwal and Mr. Manoj Kumar Agarwal.

### ***Shareholding Pattern:***

The equity shares of ASL are not listed on any stock exchange. The shareholding pattern of ASL as on the date of filing of this Prospectus,, is as follows:

<b>Sl. No.</b>	<b>Name of Shareholder</b>	<b>Number of Shares</b>	<b>% of Issued Capital</b>
1.	Suvarnapusa Investment Private Limited	1,825,500	48.46
2.	Futuristic Steels Private Limited	456,000	12.11
3.	Adhunik Corporation Limited	456,000	12.11
4.	Manohar Management Limited	252,975	6.72
5.	Murli Management Limited	183,513	4.87
6.	Northern Udyog P. Limited	182,049	4.83
7.	Neepaz Steels (India) P. Limited	148,683	3.95
8.	Jugal Kishore Agarwal	77,061	2.05
9.	Sungrowth Stocks & Shares Limited	50,000	1.33
10.	Ghanshyamdas Agarwal	21,186	0.56
11	Others	113,717	3.02
<b>TOTAL</b>		<b>3,766,684</b>	<b>100.00</b>

## *Directors*

The board of directors of ASL comprises of:

1. Mr.Ghanshyam Das Agarwal
2. Mr.Jugal Kishore Agarwal
3. Mr.Nirmal Kumar Agarwal
4. Mr.Mohanlal Agarwal
5. Mr.Mahesh Kumar Agarwal
6. Mr.Manoj Kumar Agarwal

## *Financial performance*

The unconsolidated financial results for ASL for fiscal 2003, fiscal 2004 and fiscal 2005 are as follows:

*(Rs. in lacs except share data)*

Particulars	For the year ended March 31		
	2003	2004	2005
Sales	3083.79	1054.50	3075.92
Other Income	193.99	40.74	73.10
PBIDT	279.06	145.97	396.86
PBT	4.49	124.06	29.18
PAT	111.23	(21.49)	8.95
Share Capital	299.39	299.39	302.65
Reserves & Surplus	333.88	312.38	1118.65
Net Worth	632.28	610.88	1419.93
EPS (Rs.)	3.72	(0.72)	0.30
NAV	21.12	20.40	46.92
Debt Equity Ratio	0.28	0.28	0.76
Dividend	-	-	-

## *Promise v/s Performance*

The company is unlisted and there has been no public issues in the past. We are therefore not required to furnish details of promise v/s performance.

## *Changes in capital structure*

There has been no change in the capital structure of in the last six months.

## *Details of public issue/ rights issue of capital in the last three years*

There have been no public issue of equity shares or rights issue in the three years preceding the date of this Prospectus.

## **6. Neepaz Tube Private Limited**

Neepaz Tube Private Limited (“NTPL”) was incorporated on July 2, 1999. An application dated December 22, 2005 has been filed before the High Court at Calcutta for the amalgamation of NTPL with Adhunik Alloys & Power Limited. NTPL is involved in the business of manufacturing and galvanizing of steel

tubes. Its promoters are Mr. Jugal Kishore Agarwal, Mr. Ghanshyamdas Agarwal, Mr. Mohan Lal Agarwal, Mr. Nirmal Kumar Agarwal, Mr. Mahesh Kumar Agarwal and Mr. Manoj Kumar Agarwal.

**Shareholding Pattern:**

The equity shares of NTPL are not listed on any stock exchange. The shareholding pattern of NTPL as on the date of filing of this Prospectus, is as follows:

Sl. No.	Name of Shareholder	Number of Shares	% of Issued Capital
1.	Manohar Management Limited	487,500	31.04
2.	Northern Udyog Private Limited	330,000	21.01
3.	Murli Management Limited	125,000	7.96
4.	Investwell Dealers (P) Limited	100,000	6.37
5.	Times Finance (P) Limited	100,000	6.37
6.	Trackman Sales (P) Limited	100,000	6.37
7.	Dynasty Agencies (P) Limited	100,000	6.37
8.	Mahananda Suppliers Limited	50,000	3.18
9.	Perfect Distributors (P) Limited	50,000	3.18
10.	Sun Bright Commercial (P) Limited	30,000	1.91
11.	Others	98,100	6.25
<b>TOTAL</b>		<b>1,570,600</b>	<b>100.00</b>

**Directors**

The board of directors comprises of:

1. Ghanshyamdas Agarwal; and
2. Manoj Kumar Agarwal.

**Financial Performance**

The unconsolidated financial results for NTPL for fiscal 2003, fiscal 2004 and fiscal 2005 are as follows:

*(Rs. in Lacs except share data)*

Particulars	For the year ended March 31		
	2003	2004	2005
Sales	716.59	919.74	978.08
Other Income	22.40	60.38	15.31
PBIDT	125.10	114.41	105.20
PBT	67.60	57.05	55.42
PAT	43.81	36.27	38.93
Share Capital	157.06	157.06	157.06
Reserves & Surplus	234.96	271.23	310.17
Net Worth	391.76	428.92	467.99
EPS (Rs.)	2.79	2.31	2.48
NAV	24.94	27.31	29.80
Debt Equity Ratio	0.70	0.41	0.31
Dividend		-	-

**Promise v/s Performance**

The company is unlisted and there has been no public issues in the past. We are therefore not required to furnish details of promise v/s performance.

***Changes in capital structure***

There has been no change in the capital structure of in the last six months.

***Details of public issue/ rights issue of capital in the last three years***

There have been no public issue of equity shares or rights issue in the three years preceding the date of this Prospectus.

**7. Futuristic Steel Private Limited**

Futuristic Steel Private Limited (“FSPL”) was incorporated on December 18, 1995. FSPL is involved in the business of crushing of iron ore, trading of steel products and processing of secondary products. Its promoters are Mr. Jugal Kishore Agarwal, Mr. Ghanshyamdas Agarwal, Mr. Mohan Lal Agarwal, Mr. Nirmal Kumar Agarwal, Mr. Mahesh Kumar Agarwal and Mr. Manoj Kumar Agarwal.

***Shareholding Pattern:***

The equity shares of FSPL are not listed on any stock exchange. The shareholding pattern of FSPL as on the date of filing of this Prospectus, is as follows:

<b>Sl. No.</b>	<b>Name of Shareholders</b>	<b>No. of Shares</b>	<b>% of issued capital</b>
1	Mahesh Kumar Agarwal	100	0.01
2	Sonika Agarwal	100	0.01
3	Permila Agarwal	5,000	0.72
4	Sachin Kumar Agarwal	2,500	0.36
5	Naveen Agarwal	2,000	0.29
6	G. D. Agarwal	500	0.07
7	Meena Agarwal	10,000	1.44
8	Chandrakanta Agarwal	100	0.01
9	Mahadeo Prasad Agarwal	100	0.01
10	Jugal Kishore Agarwal (HUF)	100	0.01
11	Nirmal Kumar Agarwal (HUF)	100	0.01
12	Mohan Lal Agarwal (HUF)	100	0.01
13	Manoj Kumar Agarwal (HUF)	100	0.01
14	Murli Management Limited	20,000	2.87
15	Manohar Management Limited	129,000	18.51
16	Mahadeo Ispat Private Limited	90,000	12.92
17	Mr.Bahuwala Int. Private Limited	50,000	7.18
18	Adhunik Corporation Limited	110,000	15.79
19	Suvarnapuspa Inv. Private Limited	200,000	28.70
20	Nigolice Trading (P) Limited	4,000	0.57
21	Others	73,000	10.50
<b>TOTAL</b>		<b>6,96,800</b>	<b>100.00</b>

### **Board of Directors**

The board of directors comprises of :

1. Mahesh Kumar Agarwal and
2. Mrs.. Sonika Agarwal.

### **Financial Performance**

The unconsolidated financial results for FSPL for fiscal 2003, fiscal 2004 and fiscal 2005 are as follows:

*(Rs. in Lacs except share data)*

<b>Particulars</b>	<b>For the year ended March 31</b>		
	<b>2003</b>	<b>2004</b>	<b>2005</b>
Sales	3405.28	2500.53	1745.56
Other Income	14.53	2.00	2.77
PBIDT	53.09	87.48	106.67
PBT	29.38	25.87	28.30
PAT	17.45	14.60	26.16
Share Capital	58.91	62.38	69.68
Reserves & Surplus	272.96	348.27	403.63
Net Worth	331.78	410.61	473.30
EPS (Rs.)	2.96	1.35	3.75
NAV	56.33	65.82	67.93
Debt Equity Ratio	0.10	1.67	0.25
Dividend	-	-	-

### **Promise v/s Performance**

The company is unlisted and there have been no public issues in the past. We are therefore not required to furnish details of promise v/s performance.

### **Changes in capital structure**

There has been no change in the capital structure of in the last six months.

### **Details of public issue/ rights issue of capital in the last three years**

There have been no public issue of equity shares or rights issue in the three years preceding the date of this Prospectus.

## **8. M.P. Ispat & Power Private Limited**

M.P. Ispat & Power Private Limited (“MPIPPL”) was incorporated on August 29, 2002. MPIPPL is a manufacturing industry. Its promoters are Mr. Ghanshyamdas Agarwal, Mr. Mahesh Kumar Agarwal and Mr. Manoj Kumar Agarwal.

### **Shareholding Pattern:**

The shareholding pattern of MPIPPL as on the date of filing of this Prospectus, is as follows:

Sl. No.	Name of Shareholders	Number of shares	% of Issued Capital
1	Sri. Mahesh Kumar Agarwal	3,000	30%
2	Sri. Ghanshyamdas Agarwal	3000	30%
3	Sri. Manoj Kumar Agarwal	4000	40%
TOTAL		10000	100

### ***Directors***

The board of directors comprises:

Mr. Ghanshyamdas Agarwal  
Mr. Manoj Kumar Agarwal  
Mr. Mahesh Kumar Agarwal  
Mr. Nirmal Kumar Agarwal

### ***Financial performance***

The unconsolidated financial results for MPIPPL for fiscal 2003, fiscal 2004 and fiscal 2005 are as follows:

*(Rs. in lacs except share data)*

Particulars	For the year ended March 31		
	2003	2004	2005
Sales	0.19	0.20	0.00
Other Income	-	-	-
PBIDT	0.01	0.02	(0.16)
PBT	0.01	0.02	(0.16)
PAT	0.01	0.01	(0.16)
Share Capital	1.00	1.00	1.00
Reserves & Surplus	0.01	0.02	(0.14)
Net Worth	0.68	0.78	10.15
EPS (Rs.)	0.08	0.10	-
NAV	6.85	7.75	101.50
Debt Equity Ratio	-	-	-
Dividend	-	-	-

### ***Promise v/s Performance***

The entity is a private limited company therefore is not required to furnish details of promise v/s performance.

### ***Changes in capital structure***

There has been no change in the capital structure of in the last six months.

### ***Details of public issue/ rights issue of capital in the last three years***

There have been no public issue of equity shares or rights issue in the three years preceding the date of this Prospectus.

## **9. Swarnrekha Steel Industries**

**Swarnrekha Steel Industries (“SSI”)** is a partnership firm. SSI is involved in the business of manufacturing of various kinds of iron and steel castings and processing high sulphur iron.

*Profit Sharing Pattern*

<b>Name of the Partners</b>	<b>Profit Sharing Ratio</b>
Mr. Mahesh Kumar Agarwal	50%
Mrs. Sonika Agarwal	50%

*Partners*

The partners comprises of:

1. Mr. Mahesh Kumar Agarwal
2. Mrs. Sonika Agarwal

*Financial Performance*

The unconsolidated financial results for SSI for fiscal 2003, fiscal 2004 and fiscal 2005 are as follows:

<b>Particulars (in Rs. Lacs)</b>	<b>For the year ended March 31</b>		
	<b>2003</b>	<b>2004</b>	<b>2005</b>
Sales & Other Income	1086.91	1754.15	1800.32
PAT	5.45	5.32	10.43
Partners’ Capital	42.46	250.52	249.26

*Promise v/s Performance*

The above entity is in the nature of partnership firm so there have been no public issues in the past.

**10. M/s Shivalik Transport Organisation**

M/s Shivalik Transport Organization (“STO”) is a proprietorship firm established in 1994. STO activity is of a transport agent. The proprietor of STO is Mr. Mohan Lal Agarwal

*Financial performance*

The unconsolidated financial results for STO for fiscal 2003, fiscal 2004 and fiscal 2005 are as follows:

*(Rs. in lacs)*

<b>Particulars (in Rs. Lacs)</b>	<b>For the year ended March 31</b>		
	<b>2003</b>	<b>2004</b>	<b>2005</b>
Sales/Income	355.85	520.75	629.61
PBIDT	2.58	5.95	5.50
PBT	2.58	5.94	5.50

*Promise v/s Performance*

The above entity is in the nature of proprietorship firm so there have been no public issues in the past.

## 11. Adhunik Thermal Energy Limited.

Adhunik Thermal Energy Limited (“ATEL”) was incorporated on May 3, 2005. ATEL is engaged in generation, production and distribution of thermal energy. ATEL has entered into a memorandum of understanding with the government of Jharkhand for the allotment of captive coal blocks to support the greenfield coal fired power plant. Its promoters are Mr. Jugal Kishore Agarwal, Mr. Ghanshyamdas Agarwal, Mr. Mohan Lal Agarwal, Mr. Nirmal Kumar Agarwal, Mr. Mahesh Kumar Agarwal and Mr. Manoj Kumar Agarwal.

### *Shareholding Pattern*

The equity shares of ATEL are not listed on any stock exchange. The shareholding pattern of ATEL, as on the date of filing of this Prospectus, is as given below:

Sl. No.	Name of Shareholder	Number of Shares	% of Issued Capital
1.	Jugal Kishore Agarwal	10,000	16.67
2.	Ghanshyam Das Agarwal	10,000	16.67
3.	Mahesh Kumar Agarwal	10,000	16.67
4.	Nirmal Kumar Agarwal	10,000	16.67
5.	Mohan Lal Agarwal	10,000	16.67
6.	Manoj Kumar Agarwal	10,000	16.67
<b>TOTAL</b>		<b>50,000</b>	<b>100.00</b>

### *Directors*

The board of directors of ATEL comprises of:

1. Mr. Jugal Kishore Agarwal
2. Mr. Ghanshyam Das Agarwal
3. Mr. Mahesh Kumar Agarwal
4. Mr. Nirmal Kumar Agarwal
5. Mr. Mohan Lal Agarwal
6. Mr. Manoj Kumar Agarwal

### *Financial Performance*

Since ATEL has been incorporated in May 2005, there are no financial results.

### *Promise v/s Performance*

ATEL is unlisted and has not made any public issues in the past.

### *Changes in capital structure*

There has been no change in the capital structure of in the last six months.

### *Details of public issue/ rights issue of capital in the last three years*

There have been no public issue of equity shares or rights issue in the three years preceding the date of this Prospectus.

## 12. Adhunik Metcoke Pvt. Limited

Adhunik Metcoke Pvt. Limited (“AMPL”) was incorporated on August 19, 2003. AMPL has not yet commenced its business, however proposes to manufacture iron and steel and related products. Its promoters are Mr. Nirmal Kumar Agarwal and Mr. Sachin Kumar Agarwal.

### *Shareholding Pattern*

The equity shares of AMPL are not listed on any stock exchange. The shareholding pattern of AMPL, as on the date of filing of this Prospectus, is as given below:

<b>Sl. No.</b>	<b>Name of Shareholder</b>	<b>Number of Shares</b>	<b>Capital</b>
1.	Nirmal Kumar Agarwal	5000	50
2.	Sachin Kumar Agarwal	5000	50
<b>TOTAL</b>		<b>10,000</b>	<b>100.00</b>

### *Directors*

The board of directors of AMPL comprises of:

1. Mr. Nirmal Kumar Agarwal
2. Mr. Sachin Kumar Agarwal

### *Financial Performance*

AMPL is yet to commence commercial operations.

### *Promise v/s Performance*

AMPL is unlisted and has not made any public issues in the past.

### *Changes in capital structure*

There has been no change in the capital structure of in the last six months.

### *Details of public issue/ rights issue of capital in the last three years*

There have been no public issue of equity shares or rights issue in the three years preceding the date of this Prospectus.

## 13. Manohar Management Limited

Manohar Management Limited (“MML”) was incorporated on February 18th, 2003, as a investment company and has its registered office at 25D, Harish Mukherjee Road, 1E, 1<sup>st</sup> Floor, Kolkata- 700 025

### *Shareholding Pattern:*

The equity shares of MML are not listed on any stock exchange. The shareholding pattern of MML, as on the date of filing of this Prospectus, is as given below:

Sl. No.	Name of Shareholder	Number of Shares	% of Issued Capital
1	Mr. Jugal Kishore Agarwal	43500	9.94%
2	Mr. Ghanshyamdas Agarwal	43500	9.94%
3	Mr. Nirmal Kumar Agarwal	43500	9.94%
4	Mr. Mohanlal Agarwal	43500	9.94%
5	Mr. Mahesh Kumar Agarwal	43500	9.94%
6	Mr. Manoj Kumar Agarwal	44150	10.09%
7	Sungrowth Shares & Stock Limited	105450	24.10%
8	Mahananda Suppliers Limited	70330	16.11%
<b>TOTAL</b>		437430	100.00%

**Directors:**

The present board of directors of MML comprises:

Name of the Director	Date of appointment
Mr. Narsingh Mittal	February 18, 2003
Mr. Sandeep Sharma	February 18, 2003
Mr. Ranjeet Dutta	February 18, 2003

**Financial Performance**

The unconsolidated financial results for MML for fiscal 2003, fiscal 2004 and fiscal 2005 are as follows:

*(Rs. in Lacs except share data)*

Particulars	For the year ended March 31		
	2003	2004	2005
Sales	-	-	-
Other Income	.06	0.19	0.13
PBIDT	0.00	0.00	0.00
PBT	0.00	0.00	0.00
PAT	0.00	0.00	0.00
Share Capital	5.00	21.94	43.74
Reserves & Surplus	0.00	152.11	347.87
Net Worth	4.83	173.92	391.61
EPS (Rs.)	0.00	0.00	0.00
NAV	9.66	79.27	89.52
Debt Equity Ratio	-	-	-
Dividend	-	-	-

**Promise v/s Performance**

The company is unlisted and there has been no public issues in the past. We are therefore not required to furnish details of promise v/s performance.

### ***Changes in capital structure***

There has been no change in the capital structure of in the last six months.

### ***Details of public issue/ rights issue of capital in the last three years***

There have been no public issue of equity shares or rights issue in the three years preceding the date of this Prospectus.

## **14. Adhunik Infotech Limited**

Adhunik Infotech Limited (“AITL”) was incorporated on March 20<sup>th</sup>, 2003, as a infotech company engaged in providing networking solutions and services, has its registered office at 2/1A, Sarat Bose Road, Lansdowne Towers, Kolkata - 700020

### ***Shareholding Pattern:***

The equity shares of AITL are not listed on any stock exchange. The shareholding pattern of AITL, as on the date of filing of this Prospectus, is as given below:

<b>Sl. No.</b>	<b>Name of Shareholder</b>	<b>Number of Shares</b>	<b>% of Issued Capital</b>
1	Mr. Jugal Kishore Agarwal	837810	59.77%
2	Mr. Ghanshyamdas Agarwal	376000	26.82%
3	Mahananda Suppliers Limited	140000	9.99%
4	Murli Management Limited	46700	3.33%
5	Others	1300	0.10%
<b>TOTAL</b>		<b>1401810</b>	<b>100%</b>

### ***Directors:***

The present board of directors of AITL comprises:

<b>Name of the Director</b>	<b>Date of appointment</b>
Mr. Jugal Kishore Agarwal	March 31, 2003
Mr. Ghanshyamdas Agarwal	March 31, 2003
Mr. Mahesh Kumar Agarwal	March 31, 2003
Mr. Nirmal Kumar Agarwal	April 9, 2003
Mr. Mohanlal Agarwal	April 9, 2003
Mr. Manoj Kumar Agarwal	April 9, 2003

### ***Financial Performance***

The unconsolidated financial results for AITL for fiscal 2004 and fiscal 2005 are as follows:  
(Rs. in Lacs except share data)

<b>Particulars</b>	<b>For the year ended March 31</b>	
	<b>2004</b>	<b>2005</b>
Sales	15.73	57.60
Other Income	-	5.91
PBIDT	0.14	10.73
PBT	0.14	6.05
PAT	0.09	(4.45)
Share Capital	126.18	140.18
Reserves & Surplus	70.75	136.25
Net Worth	195.32	326.59
EPS (Rs.)	0.01	0.00
Book Value per share (Rs.)	15.48	23.30
Debt Equity Ratio	0.66	1.11
Dividend	-	-

### ***Promise v/s Performance***

The company is unlisted and there has been no public issues in the past. We are therefore not required to furnish details of promise v/s performance.

### ***Changes in capital structure***

There has been no change in the capital structure of in the last six months.

### ***Details of public issue/ rights issue of capital in the last three years***

There have been no public issue of equity shares or rights issue in the three years preceding the date of this Prospectus.

**Companies from which Promoters have disassociated during preceding three years**

There are no companies from which our Promoters have disassociated during the preceding three years.

**Companies for which application has been made for striking of name**

**There are no companies from which for which application has been made for striking of name.**

**Related Party Transactions**

For more information on Related Party Transactions please see the section titled “Financial Statements” on page 148 of this Prospectus.

## **EXCHANGE RATES**

Conversion of foreign currency amounts into equivalent rupee amounts has been done as per Accounting Standard 11 i.e. “Effects of changes in foreign exchange rates” issued by the Institute of Chartered Accountants of India.

## **CURRENCY OF PRESENTATION**

In this Prospectus, unless the context otherwise requires, all references to the word “Lakh” or “Lac”, means “One hundred thousand” and the word “million” means “Ten Lacs” and the word “Crore” means “ten million”. In this Prospectus, any discrepancies in any table between total and the sum of the amounts listed are due to rounding off.

All references to “Rupees” and “Rs.” in this Prospectus are to the legal currency of India.

## **DIVIDEND POLICY**

The declaration and payment of dividends on our equity shares is recommended by the Board of Directors and approved by the shareholders, at their discretion, and will depend on a number of factors, including but not limited to the profits, capital requirements and overall financial condition.

## AUDITOR'S REPORT

To,  
The Board of Directors  
Adhunik Metaliks Limited  
14 N.S Road,  
Kolkata 700 001

Dear Sirs,

We have examined the financial information of Adhunik Metaliks Limited ('the Company') annexed to this report which have been prepared in accordance with the requirements of:

- a. paragraph B(I) of Part II of Schedule II to the Companies Act, 1956 ('the Act'); and
- b. the Securities and Exchange Board of India (Disclosure and Investor Protection) Guidelines, 2000 ('the Guidelines'), issued by the Securities and Exchange Board of India (SEBI) on January 19, 2000 as amended, in pursuance of Section 11 of the Securities and Exchange Board of India Act, 1992, to be included in the Prospectus of the Company.

The PROSPECTUS will be for a fresh issue by the Company of 270, 27, 027 equity shares of Rs 10 each at, such premium, by way of book building process, as may be decided by the Board of Directors (referred to as ' the Offer'). The offer is being made through the 100 percent book-building scheme.

### **Financial Information as per audited financials statements**

1.01 We have examined the attached 'Statement of Adjusted assets and liabilities' of the Company as at 31<sup>st</sup> March 2002, 2003, 2004, 2005 and nine months period ended on 31<sup>st</sup> December, 2005 and the attached 'Statements of Adjusted Profits and Losses' & 'Statement of Adjusted Cash Flows' of the Company for each of the years/ period ended on those dates (see Annexures 1, 2 & 3) as prepared by the Company and approved by the Board of Directors. We have also examined the Statement of Notes to the Adjusted Profits and Losses' and Assets and Liabilities as enclosed in Annexure 4. The financial statements of the Company for the period / years ended 31<sup>st</sup> March 2002, 2003 & 2004 have been audited and reported upon by M/s ABR & CO., Chartered Accountants and we have audited the financial statements of the Company for the year ended 31<sup>st</sup> March 2005 & for the nine months period ended 31<sup>st</sup> December, 2005. Based on our examination of these summary statements, we confirm that:

- a) There is no impact on the financial statements of the previous periods/years ending 31<sup>st</sup> March 2002, 2003, 2004 and 2005 arising out of changes in accounting policies followed by the Company for the nine months period

ended 31<sup>st</sup> December, 2005 vis a vis for the periods/years ending 31<sup>st</sup> March 2002, 2003, 2004 and 2005.

- b) There is no material prior period item requiring adjustment in the summary statement in the above mentioned years/periods;
- c) There is no extraordinary items, which need to be disclosed separately in the summary statements; and
- d) There are no qualification in the auditor's report which require any adjustment to the summary statements other than as mentioned vide para 1.02 below.

1.02 In our audit for the year ended March 31, 2005, we have observed that the Company accounted for consumption/capitalization of stores, spares and building materials on the basis of intended end use at the point of procurement. The stock of such materials had been accounted for on the basis of physical verification carried out by an independent firm of Chartered Accountants and Capitalisation was certified by independent Chartered Engineer. This differs from the generally accepted accounting practice in India. The effect, if any, arising from such practice on the accounts was not ascertainable and hence not been adjusted.

2.0 The summary of significant accounting policies adopted by the Company together with the notes pertaining to the audited financial statements for the nine months period ended 31<sup>st</sup> December , 2005 are enclosed as per Annexures 5 and 6 respectively to this report.

#### **Other Financial information**

3.0 We have examined the following financial information of the Company proposed to be included in the PROSPECTUS as approved by you and annexed to this report:

- i. Statement of Accounting Ratios based on the restated profits relating to earnings per share , net asset value and return on net worth is enclosed in Annexure 7;
- ii. Statement of Names of Related Parties is enclosed in Annexure 8;
- iii. Statement of Aggregated Related Party Transactions is enclosed in Annexure 8a;
- iv. Statement of Tax Shelter is enclosed in Annexure 9;
- v. Capitalization statement as at 31<sup>st</sup> December , 2005 is enclosed in Annexure 10;
- vi. Statement of Adjusted Balance of Debtors is enclosed in Annexure 11;
- vii. Statement of Adjusted Balance of Loans & Advances is enclosed in Annexure 12;
- viii. Statement of Secured Loans is enclosed in Annexure 13;
- ix. Statement of Terms and Conditions of Secured Loans is enclosed in Annexure 13a;

- x. Statement of Unsecured Loans is enclosed in Annexure 14;
  - xi. Statement of Terms and Conditions of Unsecured Loans is enclosed in Annexure 14a;
  - xii. Statement of Adjusted Other Income is enclosed in Annexure 15;
  - xiii. Statement of Investments is enclosed in Annexure 16;
  - xiv. Statement of Working Capital available to the company is enclosed in Annexure 17
  - xv. Statement of Possible Tax Benefits available to the Company and shareholders is enclosed in Annexure 18
- 4.0 The Company has not declared any dividend on equity shares for the period ended 31<sup>st</sup> December, 2005 and years ended 31<sup>st</sup> March 2002, 2003, 2004 & 2005;
- 5.0 For the purpose of our examination of the Summary Statements and other financial information, as restated of the Company, we have relied on the audited financial statements reported upon by the other auditors as discussed in para 1.01 above. We have not performed any audit procedures in respect of the financial statements for the periods/ years ended 31<sup>st</sup> March 2002, 2003 & 2004. We make no representation regarding these audited financial statements and assume no responsibility regarding the adequacy of the other auditor's procedures for your purposes.
- 6.0 In our view, the financial information as per audited financial statements and other financial information mentioned above have been prepared in accordance with Part II of Schedule II of the Act and the Guidelines.
- 7.0 This report is intended solely for your information and for inclusion in the PROSPECTUS in connection with the proposed Initial Public Offer of the Company and is not to be used, referred to or distributed for any other purpose without our prior written consent.

22 Camac Street  
Block 'C', 3<sup>rd</sup> Floor  
Kolkata 700 016  
Dated : February 24 ,2006

**S. R. BATLIBOI & COMPANY**  
CHARTERED ACCOUNTANTS

Per  
RAHUL ROY  
*a Partner*  
Membership No: 53956

STATEMENT OF ADJUSTED PROFITS AND LOSSES					
					<i>Rs. In lacs</i>
Particulars	For the year / period ended 31st March				31st
	2002	2003	2004	2005	December
	(20.11.01 to 31.03.02)				2005
					( 9 months)
<b>Income</b>					
<b>Sales:</b>					
Of products manufactured by the Company (Net of Excise Duty)	-	-	2,508.08	9,369.09	10,330.39
Of products traded by the Company	-	-	830.51	2,382.57	11,637.55
Conversion Charges ( Net of Excise Duty)	-	-	-	1,166.78	1,946.78
Other Income	0.20	0.35	236.77	117.03	130.47
<b>Total Income</b>	<b>0.20</b>	<b>0.35</b>	<b>3,575.36</b>	<b>13,035.47</b>	<b>24,045.19</b>
<b>Expenditure</b>					
Raw Materials & Goods Consumed including expenses on conversion job	-	-	1,789.49	6,503.38	6,124.19
Decrease/ (Increase) in Inventories	-	-	(620.96)	132.34	(65.53)
Purchase of Trading Goods	-	-	790.66	2,218.98	10,302.65
Personnel Cost	-	-	22.28	126.54	228.54
Other Manufacturing Expenses	-	-	291.54	1,073.72	2,332.47
Administrative and other expenses	0.08	0.24	109.41	317.21	329.61
Selling and Distribution Expenses	-	-	288.01	1,076.26	646.70
Interest	0.04	-	103.65	298.99	649.55
Depreciation	-	-	73.72	220.73	438.34
Preliminary Expenditure written off	0.07	0.07	3.80	3.83	2.88
<b>Total Expenditure</b>	<b>0.19</b>	<b>0.31</b>	<b>2,851.60</b>	<b>11,971.98</b>	<b>20,989.39</b>
<b>Net Profit Before Tax and Extraordinary Items</b>	<b>0.01</b>	<b>0.04</b>	<b>723.76</b>	<b>1,063.49</b>	<b>3,055.79</b>
<b>Provision for Taxation:</b>					
<b>Fringe Benefit Tax</b>	-	-	-	-	6.48
<b>Current Tax</b>	-	0.02	55.64	88.26	257.15
<b>Deferred Tax Liability / (Asset)</b>	-	-	257.54	265.40	1,110.89
<b>Net Profit after tax and before Extraordinary Items</b>	<b>0.01</b>	<b>0.02</b>	<b>410.58</b>	<b>709.83</b>	<b>1,681.27</b>
Extraordinary Items (net of tax)	-	-	-	-	-
<b>Net Profit after Extraordinary Items</b>	<b>0.01</b>	<b>0.02</b>	<b>410.58</b>	<b>709.83</b>	<b>1,681.27</b>
Earlier Year adjustments	-	-	-	-	-
<b>Appropriations</b>					
Balance brought forward from previous year	-	0.01	0.03	410.61	1,120.44
Transfer to General Reserve	-	-	-	-	-
Proposed Dividend	-	-	-	-	-
Tax on Proposed Dividend	-	-	-	-	-
Balance carried to Balance Sheet	<b>0.01</b>	<b>0.03</b>	<b>410.61</b>	<b>1,120.44</b>	<b>2,801.72</b>

**Notes:**

(1) The above figures should be read with the Statement of Significant Accounting Policies and Statement of Notes on Adjusted Profits & Losses and Assets & Liabilities, as appearing in Annexure 4 and 5 respectively.

(2) Necessary adjustments have been made to the audited financial statements in accordance with the requirements of paragraph 6.10.2 of The Securities and Exchange Board of India (Disclosure and Investor Protection) Guidelines, 2000.

STATEMENT OF ADJUSTED ASSETS AND LIABILITIES					
					<i>Rs. In lacs</i>
Particulars	As at 31st March				As at 31st December
	2002	2003	2004	2005	2005
	(20.11.01 to 31.03.02)	12 months	12 months	12 months	9 month
<b>A</b>	<b>Application of Funds</b>				
<b>Fixed Assets</b>					
Gross Block	-	-	2,942.51	5400.55	20,360.40
Less : Depreciation	-	-	74.41	308.09	823.09
Net Block	-	-	2,868.10	5,092.46	19,537.31
Capital Work In Progress	-	1,486.14	1,095.56	9,765.18	3,380.99
Preoperative & Trial Run Expenses (Pending Allocation)	-	-	32.73	416.65	131.56
	-	1,486.14	3,996.39	15,274.29	23,049.87
<b>B Investments</b>	108.54	7.65	7.65	7.65	7.65
<b>C Current assets, loans and advances</b>					
Inventories	-	-	1,711.85	1,281.22	9,600.25
Sundry Debtors	0.20	-	243.22	1,360.92	6,355.13
Cash & Bank Balances	1.83	48.70	126.84	586.90	1,434.19
Loans and advances	1.02	276.68	653.54	1,798.05	4,819.55
<b>Total</b>	<b>3.05</b>	<b>325.38</b>	<b>2,735.45</b>	<b>5,027.09</b>	<b>22,209.12</b>
<b>D DEFERRED TAX ASSET (net)</b>	-	-	-	-	-
<b>TOTAL ASSETS</b>	<b>111.59</b>	<b>1,819.17</b>	<b>6,739.49</b>	<b>20,309.03</b>	<b>45,266.63</b>
<b>E Liabilities &amp; Provisions</b>					
Secured Loans	-	21.32	2,451.26	8,975.23	16,877.41
Unsecured Loans	-	-	276.50	424.04	1,865.95
Deferred Tax Liabilities	-	-	257.53	522.93	1,633.82
Current Liabilities	0.57	823.53	1,002.16	2612.88	12,963.51
Provisions	0.01	0.01	37.83	24.82	173.36
<b>Total Liabilities</b>	<b>0.58</b>	<b>844.86</b>	<b>4,025.28</b>	<b>12,559.90</b>	<b>33,514.06</b>
<b>F Net Worth</b>	<b>111.01</b>	<b>974.31</b>	<b>2,714.22</b>	<b>7,749.13</b>	<b>11,752.58</b>
<b>G Represented by :</b>					
<b>Shareholder's Funds</b>					
a. Share Capital	12.85	97.10	1,868.99	5,807.26	6,420.42
b. Share Application Money ( Pending allotment)	0.77	21.57	448.50	152.96	-
c. Reserves and Surplus	97.69	855.86	411.93	1,800.26	5,340.63
	111.31	974.53	2,729.42	7,760.48	11,761.05
Less: Miscellaneous Expenditure not written off	0.30	0.22	15.21	11.35	8.47
<b>Total</b>	<b>111.01</b>	<b>974.31</b>	<b>2,714.21</b>	<b>7,749.13</b>	<b>11,752.58</b>

**Notes:**

- (1) The above figures should be read with the Statement of Significant Accounting Policies and Statement of Notes on Adjusted Profits & Losses and Assets & Liabilities, as appearing in Annexure 4 and 5 respectively.
- (2) Necessary adjustments have been made to the audited financial statements in accordance with the requirements of paragraph 6.10.2 of The Securities and Exchange Board of India (Disclosure and Investor Protection) Guidelines, 2000

STATEMENT OF ADJUSTED CASH FLOWS					
(Rs. in lacs)					
	For the year / period ended 31st March				31st December
	2002	2003	2004	2005	2005
	(20.11.01 to 31.03.02)				(9 months)
<b>A. CASH FLOW FROM OPERATING ACTIVITIES :</b>					
Adjusted Profit /(Loss) before Tax and Extraordinary Items	0.01	0.04	723.76	1,063.49	3,055.79
Adjustments for :					
Depreciation	-	-	73.72	220.73	438.34
Gratuity & Leave Provision	-	-	0.69	3.27	2.74
Interest Expenses	0.04	-	103.65	298.99	649.55
Prior Period Expenses	-	-	-	1.08	-
Preliminary Expenses written off	0.07	0.07	3.80	3.83	2.88
Interest Income	-	-	(0.37)	(9.71)	(53.19)
Profit on sale of Fixed Asset	-	(0.03)	-	-	-
<b>Operating Profit before Working Capital Changes :</b>	<b>0.12</b>	<b>0.09</b>	<b>905.24</b>	<b>1,581.68</b>	<b>4,096.11</b>
Adjustments for :					
Trade & Other Receivables	(1.22)	(275.46)	(792.83)	(2,256.46)	(7,058.33)
Inventories	-	-	(1,711.85)	430.64	(8,319.03)
Trade & Other Payables	0.57	421.10	332.08	939.57	10,542.74
Cash Generated from Operations :	<b>(0.53)</b>	<b>145.73</b>	<b>(1,267.36)</b>	<b>695.43</b>	<b>(738.51)</b>
Direct Taxes( Paid) / Refunds	-	-	(0.01)	(59.94)	(117.82)
<b>Net Cash from Operating Activities</b>	<b>(0.53)</b>	<b>145.73</b>	<b>(1,267.37)</b>	<b>635.49</b>	<b>(856.33)</b>
<b>B. CASH FLOW INVESTING ACTIVITIES :</b>					
Acquisition of Fixed Assets	-	(1,486.14)	(2,664.39)	(10,515.85)	(8,213.92)
Purchase of Investments	(108.54)	-	-	-	-
Sundry Creditors for Capital Goods	-	401.56	-	-	-
Sale of Fixed Asset	-	0.03	-	-	-
Sale of Investments	-	100.89	-	100.00	-
Preliminary Expenditure	(0.37)	-	(18.80)	-	-
Interest received	-	-	0.37	3.97	13.86
Loans to Bodies Corporate	-	-	-	-	(918.04)
<b>Net Cash from Investing Activities</b>	<b>(108.91)</b>	<b>(983.66)</b>	<b>(2,682.82)</b>	<b>(10,411.89)</b>	<b>(9,118.10)</b>
<b>C. CASH FLOW FROM FINANCING ACTIVITIES :</b>					
Issue of share Capital	12.86	84.25	-	-	-
Receipts of share application money	0.77	20.80	1,344.30	3,408.15	460.19
Receipts of Securities Premium	97.69	758.15	-	591.13	1,859.10
Borrowings (net)	-	21.32	2,706.45	6,391.10	9,344.09
Interest Paid	(0.04)	-	(103.48)	(298.43)	(650.31)
<b>Net Cash from Financing Activities</b>	<b>111.28</b>	<b>884.52</b>	<b>3,947.28</b>	<b>10,091.95</b>	<b>11,013.07</b>
<b>D. Net Cash &amp; Cash Equivalents received on Amalgamation</b>	-	-	-	34.49	-
<b>NET CHANGES IN CASH &amp; CASH EQUIVALENTS (A+B+C+D)</b>	<b>1.83</b>	<b>46.58</b>	<b>(2.91)</b>	<b>350.05</b>	<b>1,038.64</b>
Cash & Cash equivalents - Opening Balance	-	1.83	48.41	45.50	395.55
Cash & Cash equivalents - Closing Balance	<b>1.83</b>	<b>48.41</b>	<b>45.50</b>	<b>395.55</b>	<b>1,434.19</b>

## Notes:

**Cash & Cash Equivalents:**

Cash, Cheques/Drafts in hand	1.75	11.48	41.09	155.07	77.19
Balance with scheduled Banks					
In Current Account	0.08	36.87	(39.27)	(163.45)	943.93
In Fixed Deposit including Margin Money		0.06	43.68	403.92	413.07
	<b>1.83</b>	<b>48.41</b>	<b>45.50</b>	<b>395.55</b>	<b>1,434.19</b>

**Statement of Notes to the Adjusted Profits and Losses and Assets and Liabilities**

**1** The Company has changed its name from Neepez Metalliks Limited to Ahunik Metalliks Limited vide certificate of incorporation dated 9th August 2005.

**2 Amalgamation of Adhunik Minerals & Alloys Limited (AMAL) with the Company**

**(a)** Pursuant to scheme of Amalgamation as approved by the Hon'ble High Court of Kolkata vide order dated 11.04.2005 and approval dated 21.05.2005 of Registrar of Company for the merger, the business of erstwhile Adhunik Minerals & Alloys Limited (AMAL) along with related assets and liabilities has been transferred to and vested with the Company with effect from appointed date 1st April 2004. The principal business of AMAL is coal washery. From 1st April, 2004, the Company has carried out the business of erstwhile AMAL as trustee. All transactions during the year 2004-05 relating to erstwhile AMAL (after eliminating profit element in inter unit transaction) has been incorporated in the Books of Accounts of the Company. As per aforesaid scheme of amalgamation, difference of Rs. 87.35 lacs arising between the net assets transferred as of 1st April, 2004 and the equity share issued (as computed below) has been credited to General Reserve

<b>Particulars</b>	<b>Rs in lacs</b>
Fixed Assets & Capital Work-in-Progress	407.10
Investment	100.00
Net Current Assets	95.23
<b>Total (A)</b>	<b>602.34</b>
Less: Secured Loan	280.39
Share Application Money	25.00
Amount of Equity Share issued to the Shareholders of erstwhile AMAL	209.59
<b>Total (B)</b>	<b>514.98</b>
<b>General Reserve (A-B)</b>	<b>87.35</b>

**(b)** The amalgamation has been accounted for under "Pooling of Interest Method" of accounting as prescribed by Accounting Standard - 14 "Accounting for Amalgamations" issued by the Institute of Chartered Accountants of India.

**(c)** Certain Leasehold right, Building, Licenses, Agreements, Loan documents, etc., are in process of being transferred in the name of the Company. In term of the Scheme, all employees in service of erstwhile AMAL have become employees of the Company without any break or interruption in service. All rights, duties, power and obligation of erstwhile AMAL in relation to Provident Fund, Gratuity Fund, etc. are in the process of being transferred in the name of the Company.

**3 (a)** The Blast Furnace Plant, having achieved the technical parameters of operations and stabilisation of production efficiency, has commenced the commercial operation effective from 1st September 2005. Accordingly, assets of Rs. 6302.27 lacs including proportionate allocation of preoperative & trial run expenditure of Rs. 1736.62 lacs have been capitalised during the period.

**(b)** The Steel Melting Shop, having achieved the technical parameters of operation and stabilization of production efficiency, has commenced commercial operations effective from 5th November, 2005. Accordingly, assets of Rs. 6107.20 Lacs (including proportionate allocation of preoperative & trial run expenditure of Rs. 1182.68 Lacs) have been capitalised

**4** In the financial year ended 31st March 2005 stores, spares & building material consumption for revenue / capital purpose is booked directly at the time of receipt of material based on their intended use. Inventory accounted for based on physical verification by independent firm of chartered accountants and valued at lower of cost computed on FIFO basis and net relisable value. However during the current financial year, stores consumption has been booked on the basis of actual issue from stores. The aforesaid change does not have any impact in profit & loss account.

**5 Regrouping/ Adjustments**

**a)** Selling & Administrative expenses has been regrouped in selling & distribution expenses and administrative & other expenses.

(Rs in lacs)

## Statement of Notes to the Adjusted Profits and Losses and Assets and Liabilities

Contd .....Annexure 4

5b) The following regrouping has been made by the management in the accounts of the previous years and certified as appropriate by the auditors of such previous year:

Year	Amount	Increase	Decrease	Remarks if any
2001-02	0.52	Loans & Advances	Sundry Debtors	Due to regrouping
	0.50	Loans & Advances		The same was netted off in creditors
	0.50	Current Liabilities		
	0.77	Share application money	Current Liabilities	Due to regrouping of share application in Shareholder's fund
2002-03	94.94	Capital work in progress	Loans & Advances	Due to regrouping of capital advance in Capital work in progress
	140.50	Loans & Advances		The same was netted off with Sundry Creditors
	140.50	Current Liabilities		
2003-04	11.50	Sales & Services	(Increase) / Decrease in stock	As excise duty was not adjusted in increase / decrease in stock
	0.60	Raw Material consumed		Regrouping of closing stock of By-Product
	0.60	Increase in stock		
	21.57	Administrative Expenses	Interest	Finance charges regrouped in administrative expenses
	790.87	Capital work in progress	Net block	Capital work in progress shown separately
	66.00	Capital work in progress	Preoperative Expenditure	Regrouping of preoperative expenses
	238.69	Capital work in progress	Loans & Advances	Regrouping of capital advance against fixed assets
	18.84	Provisions	Loans & Advances	Adjustment of TDS receivable
2004-05	90.27	Other Income	Sales & Services	Regrouping of commission income

**Significant accounting policies adopted by the Company pertaining to the audited financial statements**

1. ACCOUNTING POLICIES:

(I) Basis of Accounting:

The Company prepares its accounts on accrual basis, except otherwise stated, in accordance with the normally accepted accounting principles.

(II) Revenue Recognition:

- (a) Revenue from sale of goods and services rendered is recognised upon passage of title and rendering of services, to the customers.
- (b) Insurance and other claims, to the extent considered recoverable, are accounted for in the year of claim. However, claims and refunds whose recovery cannot be ascertained with reasonable certainty, are accounted for on acceptance basis.

(III) Fixed Assets:

- (a) Fixed assets are stated at cost of acquisition inclusive of duties (net of Cenvat), taxes, incidental expenses, erection/commissioning expenses, and interest etc. upto the date the asset is put to use.
- (b) Machinery spares which can be used only in connection with an item of fixed assets and whose use as per technical assessment is expected to be irregular, are capitalised and depreciated over the residual useful life of the respective assets.
- (c) The carrying amounts of assets are reviewed at each balance sheet date to determine if there is any indication of impairment based on external / internal factors. An impairment loss is recognised wherever the carrying amount of an asset exceeds its recoverable amount which represents the greater of the net selling price and 'Value in use' of the respective assets. The estimated future cash flows considered for determining the value in use, are discounted to their present value at the weighted average cost of capital.
- (d) Expenditure on New Projects and Substantial Expansion:

Expenditure directly relating to construction activity is capitalised. Indirect expenditure incurred during construction period is capitalised as part of the indirect construction cost to the extent to which the expenditure is indirectly related to construction activity or is incidental thereto. Other indirect expenditure (including borrowing costs) incurred during the construction period which is not related to the construction activity nor is incidental thereto is charged to the Profit & Loss Account. Income earned during construction period is deducted from the total of the indirect expenditure.

All direct capital expenditure on expansion are capitalised. As regards indirect expenditure on expansion, only that portion is capitalised which represents the marginal increase in such expenditure involved as a result of capital expansion. Both direct and indirect expenditure are capitalised only if they increase the value of the asset beyond its original standard of performance.

(IV) Foreign Currency Transactions:

- (a) Foreign currency transactions are recorded in the reporting currency, by applying to the foreign currency amount the exchange rate between the reporting currency and the foreign currency at the date of the transaction.
- (b) Foreign currency monetary items are reported using the closing rate. Non-monetary items which are carried in terms of historical cost denominated in a foreign currency are reported using the exchange rate at the date of transaction; and non-monetary items which are carried at fair value or other similar valuation denominated in a foreign currency are reported using the exchange rates that existed when the values were determined.
- (c) Exchange differences arising on the settlement / conversion of monetary items are recognised as income or expenses in the year in which they arise except those relating to acquisition of fixed assets outside India, in which case such exchange differences are capitalised.  
The premium or discount arising at the inception of forward exchange contracts is amortised as expenses or income over the life of respective contracts. Exchange differences on such contracts are recognized in the statement of profit and loss in the year in which the exchange rates change. Any profit or loss arising on cancellation or renewal of forward exchange contract is recognised as income or as expense for the year.

(V) Depreciation:

- (a) The Classification of Plant and Machinery into continuous and non-continuous process is done as per technical certification and depreciation thereon is provided accordingly.
- (b) Depreciation on Fixed Assets is provided on Straight Line Method at the rates specified in Schedule XIV of the Companies Act, 1956 or estimated useful life whichever is higher.
- (c) Depreciation includes the amount written off in respect of leasehold land over the respective lease period.
- (d) Depreciation on fixed assets added / disposed off during the year, is provided on pro-rata basis with reference to the month of addition / disposal.
- (e) Discarded Fixed Assets awaiting disposal are valued at estimated realisable value and disclosed separately.
- (f) In case of impairment, if any, depreciation is provided on the revised carrying amount of the assets over its useful life.

(VI) Fixed Assets acquired under leases

- (a) (i) Assets acquired under lease agreements which effectively transfer to the Company substantially all the risks and benefits incidental to ownership of the leased items, are capitalised at the lower of the fair value and present value of the minimum lease payments after discounting them at an appropriate discount rate at the inception of the lease term and disclosed as leased assets. Lease payments are apportioned between the finance charges and reduction of the lease liability so as to achieve a constant rate of interest on the remaining balance of the liability. Finance charges are charged directly to Expenses account.
- (ii) Leased assets capitalised, if any, are depreciated over the shorter of the estimated useful life of the asset or the lease term.
- (b) Leases where the lessor effectively retains substantially all the risks and benefits of ownership of the leased assets, are classified as operating leases. Operating lease payments are recognised as an expense in the Profit and Loss Account on a straight line basis over the lease term.

(VII) Investments :

Current quoted investments are stated at lower of cost or market rate on individual investment basis. Unquoted and long term investments are considered at cost, unless there is a permanent decline in value thereof, in which case, adequate provision is made against such diminution in the value of investments.

(VIII) Inventories :

- (a) Raw Materials & Packing Materials & Trading Goods are valued at lower of cost computed on FIFO basis and net realisable value.
- (b) Stores , spares and building materials consumption for revenue / capital purpose is booked directly at the time of receipt of materials based on their intended use. Inventory is accounted for based on physical verification by independent firm of chartered accountants and valued at lower of cost computed on FIFO basis and net realisable value till 31st March,2005 . However since 1st April , 2005 onwards the same has been valued at lower of cost computed on FIFO basis and net realisable value.
- (b) Finished Goods are valued at lower of cost computed on annual average basis and net realisable value.
- (c) By-products are valued at net realisable value.

(IX) Excise Duty & Custom Duty:

Excise Duty on Finished Goods stock lying at the factories is accounted for at the point of manufacture of goods and is accordingly considered for valuation of finished goods stock lying in the factories as on the Balance Sheet date, Similarly, Custom Duty on Imported Materials in transit / lying in Bonded Warehouse is accounted for at the time of import / bonding of materials.

(X) Retirement and other Employee Benefits :

- (a) Gratuity and Leave liability are provided on the basis of actuarial valuation made as on the Balance Sheet date.
- (b) Retirement benefit in the form of contribution to Provident Fund is charged to the Profit & Loss Account in the year when they become payable.

(XI) Borrowing Costs :

Borrowing costs that are directly attributable to the acquisition or construction of qualifying assets are capitalised until the time all substantial activities necessary to prepare the qualifying assets for their intended use are complete. A qualifying asset is one that necessarily takes substantial period of time to get ready for its intended use. All other borrowing costs are charged to revenue.

(XII) Provisions :

A provision is recognised when an enterprise has a present obligation as a result of past event and it is probable that an outflow of resources will be required to settle the obligation, in respect of which a reliable estimate can be made.

Provisions made in terms of Accounting Standard 29 are not discounted to its present value and are determined based on the management estimates required to settle the obligation at the balance sheet date. These are reviewed at each balance sheet date and adjusted to reflect the current management estimates.

(XIII) Taxation :

Provision for Income Tax comprises of current tax, tax on fringe benefit and deferred tax charge or release. Current income- tax is measured at the amount expected to be paid to the tax authorities in accordance with the Indian Income Tax Act, 1961. Tax on fringe benefits is measured at a specified rate on the value of fringe benefits in accordance with the provisions of Section 115WC of the Income Tax Act , 1961. Deferred income taxes reflects the impact of current year timing differences between taxable income and accounting income for the year and reversal of timing differences of earlier years. Deferred tax is measured based on the tax rates and the tax laws enacted or substantively enacted at the balance sheet date. Deferred tax assets are recognised only to the extent that there is 'reasonable certainty' that sufficient future taxable income will be available against which such deferred tax assets can be realised.

(XIV) Segment Reporting :

Segment Reporting as defined in Accounting Standard 17 is not applicable since the Company has identified Iron & Steel products as the segment.

(XV) Contingencies :

Liabilities which are material and whose future outcome cannot be ascertained with reasonable certainty, are treated as contingent and disclosed by way of Notes to the Accounts.

(XVI) Earning per share :

Earning per share is calculated by dividing the net profit or loss for the period attributable to equity shareholders, by the weighted average number of equity shares outstanding during the period.

For the purpose of calculating diluted earnings per share, the net profit or loss for the period attributable to equity shareholders and weighted average number of shares outstanding during the period are adjusted for the effects of all dilutive potential equity shares.

(XVII) Miscellaneous Expenses

Preliminary expenses are amortized over a period of five years.

## Notes to Accounts pertaining to audited financial statement for the period ended December 31, 2005

	31st Dec 05 Rs in lacs
1 Estimated amount of contracts remaining to be executed on capital account and not provided for (Net of advances).	3,662.72
2 Contingent Liabilities not provided for in respect of:	
(a) Claims & Government demands against the Company not acknowledged as debt	54.57
(b) Outstanding Bank Guarantees	186.50
(c) Corporate guarantee issued to Bank on behalf of Adhunik Infotec Limited, a Company under the same management	200.00
3 (a) The Rupee Term Loans from banks are secured by way of equitable mortgage by deposit of title deeds of the Company's immovable properties both owned and leasehold and building at Chadrihariharpur Kuarmunda, Sundargarh, Orissa and a first charge by way of hypothecation of the Company's moveable assets (save and except book debts) including machinery, machinery spares, tools and accessories, present and future subject to prior charges created and/or to be created in favour of the Company's bankers for securing working capital facilities.	
(b) The Cash credit and other working capital facility from banks are secured by the hypothecation of consumable stores, raw materials, finished goods, process stock, book debts (both present and future).	
(c) Both Rupee Term Loan and working capital facility from banks (as specified in 4 (a) & (b) above) are further secured by extension of equitable mortgage of landed properties at village- Jugiana, Dist.- Ludhiana, Punjab, registered in the name of M/S Adhunik Steels Ltd, extension of equitable mortgage of landed properties at Jamshedpur, registered in the name of M/S Neepaz Tube (P) Limited; Recurring Deposit Account in the name of the Company; Fixed Deposit in the name of the promoters / guarantors; corporate guarantee of M/S Adhunik Steels Ltd. and M/s Neepaz Tubes Pvt. Ltd. and personal guarantee of all the directors of the Company.	
(d) Others loans availed for acquiring equipments/vehicles are secured by Hypothecation of the respective equipments/vehicles.	
(e) Term loan & Equipment/Vehicle Finance loan aggregating to Rs.2744.30 lacs are payable within one year.	
4 a) The Blast furnace Plant, having achieved the technical parameters of operation and stabilization of production efficiency, has commenced commercial operations effective from 1st September, 2005. Accordingly, assets of Rs. 6302.27 Lacs (including proportionate allocation of preoperative & trial run expenditure of Rs. 1736.62 Lacs) have been capitalised during the period.	
b) The Steel Melting Shop, having achieved the technical parameters of operation and stabilization of production efficiency, has commenced commercial operations effective from 5th November, 2005. Accordingly, assets of Rs. 6107.20 Lacs (including proportionate allocation of preoperative & trial run expenditure of Rs. 1182.68 Lacs) have been capitalised during the period.	
5 In terms of Accounting Standard - 22, net deferred tax liability of Rs. 1633.82 Lacs has been recognised in the accounts upto 31st December 2005. The break up of such Deferred Tax Liability of Rs. 1633.82 Lacs as on 31st December 2005 is as follows:	<b>Rs in lacs</b>
i) Timing Difference in Depreciable Assets	1678.20
ii) Other Timing Difference	(44.38)
<b>Total</b>	<u><u>1,633.82</u></u>

## STATEMENT OF ADJUSTED ACCOUNTING RATIOS

Accounting Ratios	for the year / period ended 31st March				31st December
	2002	2003	2004	2005	2005 (9 months)
Networth (A) (in lacs)	111.01	974.31	2,714.21	7,749.13	11,752.58
Adjusted Profit after Tax (B) (in lacs)	0.01	0.02	410.58	709.83	1,681.27
No. of Shares outstanding at the end (C)	128,540	971,040	18,689,912	54,072,672	64,204,220
Weighted Average No. of Shares outstanding (D)	8,553,121	8,844,733	12,244,435	34,391,782	57,314,110
Diluted/Weighted average number of outstanding equity Shares	8,555,997	8,931,838	12,970,501	38,280,002	57,314,110
Nominal Value per share	10	10	10	10	10
Basic Earnings per Share ( Before Extraordinary					
a) Items) (Rs.)	0.00	0.00	3.35	2.06	2.93
Diluted Earning per share (Rs.) (Before Extraordinary					
b) items)	0.00	0.00	3.17	1.85	2.93
c) Return on Net Worth(%)	0.00	0.00	15.13	9.16	14.31
d) Net Asset Value per Share (Rs.)	86.36	100.34	14.52	14.33	18.30

## NOTES:

Defination of ratios:

a) Earning per share ( EPS)

Adjusted Profit/(Loss) after tax and excluding extraordinary items as per statement of Adjusted Profits /(Losses), divided by the weighted average number of outstanding equity shares during the year/period.

b)Return on net worth

Profit/(Loss) after tax as per statement of adjusted Profits and Losses, divided by net worth.

c) Net Assests Value

Net worth as per statement of Adjusted Assets and Liabilities, divided by the number of equity shares at the end of the year/period.

## Statement of Related Party Disclosures as per Accounting Standard 18

## (a) Name of the related parties :

Associate Companies	Sungrowth Shares & Stock Limited Mahananda Suppliers Ltd. *
Key Management Personnel	Mr. Ghanshyam Das Agarwal Mr. Manoj Kumar Agarwal Mr. Jugal Kishore Agarwal Mr. Nirmal Kumar Agarwal
Relatives of Key Management personnel	Mr. Mohan Lal Agarwal (Brother of Mr Manoj Kumar Agarwal) Mr. Mahesh Kumar Agarwal (Brother of Mr Manoj Kumar Agarwal) Mrs. Sonika Agarwal (Wife of Mr. Manoj kumar Agarwal) Mrs. Pramila Agarwal (Wife of Mr. Jugal kishore Agarwal) Mrs. Anita Agarwal (Wife of Mr. Nirmal kumar Agarwal) Mr. Naveen Agarwal (Son of Mr. Jugal kishore Agarwal) Mr. Sachin Agarwal (Son of Mr. Jugal Kishore Agarwal)
Enterprises over which Key Management	Adhunik Corporation Ltd. Adhunik Steels Ltd. Adhunik Ferro Alloys Ltd. Adhunik Alloys & Power Ltd. Adhunik Meghalaya Steels (Private) Ltd. Neepez Tube (Private) Limited Futuristic Steels (Private) Ltd. Northern Udyog (Private) Ltd. ** Adhunik Minerals & Alloys Limited*** Pragati Ispat Udyog Swarnarekha Steel Industries Ganges Enterprises Adhunik Infotech Ltd. Adhunik Ispat (Private) Ltd. Sri MP Ispat & Power (Private) Ltd. Balaji Enterprise Salasar Enterprise Mahananda Suppliers Ltd. Manohar Management Ltd. Shivalik Transport Mahadeo Prasad Agarwal (HUF) Ghanshyam Das Agarwal (HUF)

\* Mahananda Suppliers became an associate w.e.f. February 2005

\*\* Merged with Adhunik Steels Ltd. w.e.f. April 1, 2004

\*\*\* Merged with the company w.e.f. April 1, 2004

## ANNEXURE 8A

Rs. In Lacs

Name of the Related Party		Advance against Sale	Advance for Purchase	Purchase of goods	Sales of goods	Conversion Charges, Hire charges, Accounting & Maintenance charges and Rent	Hire charges received	Finance - equity contributions	Purchase of Fixed Assets	Purchase of Investment	Sale of Investment	Guarantee Given	Remuneration to Managing Director	Balance outstanding as at the year end - Debit	Balance outstanding as at the year end - Credit
<b>Associate Companies</b>															
Sungrowth Shares & Stock Ltd.	31.12.2005	-	-	-	-	-	-	-	-	-	-	-	-	-	-
	2004-05	-	-	-	-	-	-	1,250.50	-	-	100.00	-	-	-	-
	2003-04	-	-	-	-	-	-	564.50	-	-	-	-	-	-	-
	2002-03	-	-	-	-	-	-	-	-	-	-	-	-	-	-
	2001-02	-	-	-	-	-	-	-	-	-	-	-	-	-	-
Mahananda Suppliers Ltd.	31.12.2005	-	-	-	-	-	-	760.00	-	-	-	-	-	-	-
	2004-05	-	-	-	-	-	-	1,507.50	-	-	-	-	-	-	-
	2003-04	-	-	-	-	-	-	-	-	-	-	-	-	-	-
	2002-03	-	-	-	-	-	-	-	-	-	-	-	-	-	-
	2001-02	-	-	-	-	-	-	-	-	-	-	-	-	-	-
<b>Key Management Personnel</b>															
Manoj Kumar Agarwal	31.12.2005	-	3.00	-	-	-	-	-	-	-	-	-	2.24	0.76	-
	2004-05	-	-	-	-	-	-	40.00	-	-	-	-	2.88	-	-
	2003-04	-	-	-	-	-	-	0.77	-	-	-	-	0.13	-	-
	2002-03	-	-	-	-	-	-	-	-	-	-	-	-	-	-
	2001-02	-	-	-	-	-	-	0.50	-	-	-	-	-	-	-
Jugal Kishore Agarwal	31.12.2005	-	1.05	0.73	-	0.03	-	-	-	-	-	-	-	1.74	-
	2004-05	18.20	36.18	4.37	-	0.03	-	88.70	-	-	-	-	-	17.95	-
	2003-04	5.46	9.05	-	-	-	-	15.50	-	-	-	-	-	-	-
	2002-03	-	-	-	-	-	-	-	-	-	-	-	-	-	-
	2001-02	-	-	-	-	-	-	0.50	-	-	-	-	-	-	-
Nirmal Kumar Agarwal	31.12.2005	-	-	-	-	0.04	-	-	-	-	-	-	-	-	0.08
	2004-05	-	-	-	-	0.03	-	133.55	-	-	-	-	-	-	0.03
	2003-04	-	-	-	-	-	-	15.00	-	-	-	-	-	-	-
	2002-03	-	-	-	-	-	-	-	-	-	-	-	-	-	-
	2001-02	-	-	-	-	-	-	-	-	-	-	-	-	-	-

Anexure 8a contd...

<b>Relatives of Key Management Personnel</b>															
Others	31.12.2005	3.31	2.50	1.55	-	0.20	-	-	-	-	-	-	-	2.49	0.05
	2004-05	16.20	33.50	5.05	-	0.23	-	336.40	-	-	-	-	-	17.26	0.19
	2003-04	3.73	11.06	-	-	0.09	-	19.80	-	-	-	-	-	-	-
	2002-03	-	-	-	-	-	-	-	-	-	-	-	-	-	-
	2001-02	-	-	-	-	-	-	1.00	-	-	-	-	-	-	-
<b>Enterprised over which key management personnel / relatives have significant influence</b>															
Adhunik Corpn. Ltd	31.12.2005	571.05	607.25	223.29	101.62	-	-	-	-	-	-	-	-	55.19	-
	2004-05	2,685.53	2,932.73	87.15	141.73	-	-	-	-	-	-	-	-	130.07	-
	2003-04	939.94	938.47	-	11.69	-	-	190.00	-	-	-	-	-	-	-
	2002-03	439.75	525.75	-	-	-	-	-	-	-	-	-	-	86.00	-
	2001-02	-	-	-	-	-	-	-	-	-	-	-	-	-	-
Adhunik Steels Ltd	31.12.2005	294.00	194.54	-	75.41	3.00	-	339.96	-	-	-	-	-	-	73.16
	2004-05	931.18	-	-	196.45	28.95	-	-	2.18	-	-	-	-	-	384.58
	2003-04	242.11	-	-	-	-	-	-	-	-	-	-	-	-	-
	2002-03	167.78	121.30	-	-	-	-	-	-	-	-	-	-	-	46.98
	2001-02	0.50	-	-	-	-	-	-	-	-	-	-	-	-	0.50

Annexure 8a contd...

Achunik Alloys & Power Ltd	31.12.2005	8.50	-	-	4.22	-	-	-	-	-	-	-	-	-	4.28
	2004-05	787.65	-	-	96.18	-	-	-	-	-	-	-	-	-	45.22
	2003-04	275.68	-	-	-	-	-	-	-	-	-	-	-	-	-
	2002-03	-	-	-	-	-	-	-	-	-	-	-	-	-	-
	2001-02	-	-	-	-	-	-	-	-	-	-	-	-	-	-
Achunik Meghalaya Steels Pvt. Ltd.	31.12.2005	37.65	242.93	235.67	-	-	-	-	-	-	-	-	-	69.80	-
	2004-05	288.30	328.52	20.43	-	-	400.00	-	-	-	-	-	-	19.80	-
	2003-04	-	-	-	-	-	-	-	7.65	-	-	-	-	-	-
	2002-03	73.50	128.00	-	-	-	-	-	-	100.89	-	-	-	54.50	-
	2001-02	-	-	-	-	-	-	-	108.54	-	-	-	-	-	-
Futuristic Steels (P) Ltd	31.12.2005	-	55.46	-	-	11.65	4.95	-	-	-	-	-	-	-	2.00
	2004-05	1,059.86	1,105.62	715.91	-	11.63	9.00	-	-	-	-	-	-	-	12.92
	2003-04	328.56	309.57	569.65	-	15.66	10.00	-	-	-	-	-	-	-	-
	2002-03	121.90	54.30	-	-	-	-	-	-	-	-	-	-	-	67.60
	2001-02	-	-	-	-	-	-	-	-	-	-	-	-	-	-
Achunik Infotech Limited	31.12.2005	-	3.00	-	-	11.56	-	-	-	-	-	200.00	-	-	9.43
	2004-05	-	-	-	-	15.50	-	-	-	-	-	200.00	-	42.00	-
	2003-04	-	-	-	-	-	-	-	-	-	-	200.00	-	-	-
	2002-03	-	-	-	-	-	-	-	-	-	-	-	-	-	-
	2001-02	-	-	-	-	-	-	-	-	-	-	-	-	-	-
Achunik Ispat Pvt Ltd	31.12.2005	80.28	493.90	67.50	-	-	-	-	-	-	-	-	-	-	45.02
	2004-05	-	1,120.20	166.73	-	-	-	-	-	-	-	-	-	432.52	-
	2003-04	-	302.45	-	-	-	-	-	-	-	-	-	-	-	-
	2002-03	154.30	32.30	-	-	-	-	-	-	-	-	-	-	-	122.00
	2001-02	-	-	-	-	-	-	-	-	-	-	-	-	-	-
Swamirekha Steel Industries	31.12.2005	25.00	188.69	153.25	0.19	-	-	-	-	-	-	-	-	10.62	-
	2004-05	219.35	243.84	-	-	-	-	-	-	-	-	-	-	-	112.69
	2003-04	-	-	-	-	-	-	-	-	-	-	-	-	-	-
	2002-03	81.17	46.05	-	-	-	-	-	-	-	-	-	-	-	35.12
	2001-02	-	-	-	-	-	-	-	-	-	-	-	-	-	-

Annexure 8a contd...

Pragati Ispat Udyog	31.12.2005	28.50	137.29	1.64	-	-	-	-	-	-	-	-	-	43.20	-
	2004-05	169.93	316.71	58.18	-	-	-	-	-	-	-	-	-	-	-
	2003-04	-	-	-	-	-	-	-	-	-	-	-	-	-	-
	2002-03	46.55	46.55	-	-	-	-	-	-	-	-	-	-	-	-
	2001-02	-	-	-	-	-	-	-	-	-	-	-	-	-	-
Others	31.12.2005	2.92	54.51	10.28	43.46	-	-	21.00	-	-	-	-	-	49.54	0.45
	2004-05	949.79	1,758.30	-	1.19	-	-	142.75	-	-	-	-	-	31.45	102.05
	2003-04	537.03	767.74	14.78	21.07	-	-	258.50	-	-	-	-	-	38.97	42.99
	2002-03	242.52	96.80	-	-	-	-	-	-	-	-	-	-	-	146.22
	2001-02	10.50	10.00	-	-	-	-	7.54	-	-	-	-	-	-	-
<b>Total</b>	31.12.2005	1,051.21	1,984.12	693.91	224.90	26.48	4.95	1,120.96	-	-	-	200.00	2.24	233.34	134.47
	2004-05	7,126.00	7,875.61	1,057.82	435.55	56.38	9.00	3,899.40	2.18	-	100.00	200.00	2.88	691.06	657.67
	2003-04	2,332.50	2,338.34	584.43	32.76	15.75	10.00	1,064.07	-	7.65	-	200.00	0.13	38.97	42.99
	2002-03	1,327.47	1,051.05	-	-	-	-	-	-	-	100.89	-	-	140.50	417.92
	2001-02	11.00	10.00	-	-	-	-	9.54	-	108.54	-	-	-	-	0.50

**Note:**

The period referred to above is from 1st April to 31st March each year except for 2001-02 where it represents the period 20th Nov 2001 to 31st March 2002 and for 31.12.05 where it represents 9 months period from 1st April 2005 to 31st December 2005

**Annexure 9**

**Computation of Tax Shelter based on Adjusted Profit & Loss as per Schedule XII of the DIP Guidelines,2000**

Particulars	For the period/ year ended 31st March					As at 31st December 2005	*
	2002	2003	2004	*	2005		
Tax Rate including surcharge (%)	35.70%	36.75%	35.88%		36.59%	33.66%	
Profit	0.01	0.04	723.76		1063.49	3,055.79	
Tax at Notional Rate	0.00	0.01	259.69		389.13	1,028.58	
<i>Adjustments:</i>							
Export Profit / Dividends	0.00	0.00	0.00		0.00	0.00	
Difference between tax depreciation & book depreciation	0.00	0.00	722.29		912.38	3303.55	
Other Adjustments	0.00	0.00	4.42		90.09	24.55	
Net Adjustments	0.00	0.00	717.87		822.29	3279.00	
Tax Savings thereon	0.00	0.00	257.54		300.88	1103.71	
Total Taxation	0.00	0.01	2.11		88.26	0	
Taxation on extraordinary items	0.00	0.00	0.00		0.00	0	
Tax on profits before extra ordinary items	0.00	0.01	55.64	**	88.26	257.14	

**Notes:**

- \* Tax has been paid / provided under section 115JB of the Income Tax Act, (the 'Act') on book profits in respect of financial year 2003-04 and for the period ending December 31, 2005
- \*\* The tax paid / provided does not include interest under section 234C of the Act, amounting to Rs. 3.53 lacs
- \$ The figures for the nine month period ending December 31, 2005 are as provided by the Management and not from the return of income of the Company

**Annexure 10****ADJUSTED CAPITALISATION STATEMENT**

(Rs. in Lacs)

	(Rs. in Lacs)	
	Pre-issue	As adjusted for Initial Public Offer
<b>Borrowings</b>		
Short-Term	7,018.16	7,018.16
Long-Term	11,725.20	11,725.20
Total	<u>18,743.36</u>	<u>18,743.36</u>
<b>Shareholders' Funds</b>		
Share Capital		
Equity	6,420.42	9,123.12
Reserve & Surplus		
Security Premium	2,451.55	9,748.85
General Reserve	87.36	87.36
Profit & Loss Account Balance	2,801.72	2,801.72
Less : Miscellaneous Expenditure not written off	8.47	8.47
<b>Total</b>	<u>11,752.58</u>	<u>21,752.58</u>
<b>Long-term Debt/Equity ratio</b>	<u>1.00</u>	<u>0.54</u>

Note: a) Share Capital & Reserve and surplus post issue can be calculated only on the conclusion of the book building process

b) Long Term Debt includes current portion of long term debt payable over the next twelve months.

## STATEMENT OF ADJUSTED BALANCE OF DEBTORS

(Rs. in Lacs)

	(Unsecured considered good except otherwise stated)	For the period/ year ended 31st March				As at 31st December
		2002	2003	2004	2005	2005
	Debts outstanding for more then six months					
	Others	-	-	1.73	44.75	97.12
	Other Debts					
a)	Promoters	-	-	-	-	-
b)	Promoter Group Companies / Firms	-	-	0.59	-	-
c)	Others	0.20	-	240.90	1,316.17	6,258.01
	<b>Total</b>	<b>0.20</b>	<b>-</b>	<b>243.22</b>	<b>1,360.92</b>	<b>6,355.13</b>

## ADHUNIK METALIKS LIMITED

Annexure 12

## STATEMENT OF ADJUSTED BALANCE OF LOANS AND ADVANCES

	Particulars	For the period/ year ended 31st March				As at 31st December
		2002	2003	2004	2005	2005
	(Unsecured considered good except otherwise stated)					
	Advances recoverable in cash or in kind or for value to be received or pending adjustments					
(i)	a) Promoters					
	b) Promoter Group Companies / Firms	-	-	89.84	656.54	-
	c) Others	-	-	-	123.84	169.96
(ii)	Loans & Advances to Bodies Corporate					918.04
(iii)	Security Deposit [Including Deposit with Government & Semi Govt Authorities]	-	28.51	58.21	259.55	722.90
(iv)	Advances to Suppliers and others					
	a) Promoters				35.22	2.95
	b) Promoter Group Companies / Firms	-	141.85	-	-	173.16
	c) Others	1.02	19.26	417.23	284.79	2,173.19
(v)	Interest receivable	-	-	-	5.74	45.07
(vi)	Balance with Excise, Port Trust & other Govt. Authorities	-	87.06	88.27	408.74	535.26
(vii)	Sales tax, VAT and other refund receivable (including payment under appeals)	-	-	-	23.63	79.02
	<b>Total</b>	<b>1.02</b>	<b>276.68</b>	<b>653.54</b>	<b>1,798.05</b>	<b>4,819.55</b>

## Annexure 13

## STATEMENT OF ADJUSTED SECURED LOANS

(Rs. in Lacs)

Particulars	For the period / year ended 31st March				As at 31st December
	2002	2003	2004	2005	2005
<b>Debentures</b>					
Rupee term loan from Banks	-	-	1,692.01	7,853.89	11,519.40
Working Capital Finance from bank	-	-	619.42	819.28	5,152.21
Finance against Equipment/Vehicles	-	21.32	139.83	302.05	205.80
<b>Total</b>	-	<b>21.32</b>	<b>2,451.26</b>	<b>8,975.23</b>	<b>16,877.41</b>

Annexure 13a

## Break-up of Secured Loans As On 31st December, 2005

(Rs. In Lacs)

Sl. No.	Bank	Interest Rate	Sanctioned Amount	Amount Outstanding as on 31.12.05	Nature of Security	Repayment Terms
<b>A TERM LOAN</b>						
1	State Bank of India	12.25%	936.44	481.22	The Rupee Term Loans from banks are secured by way of equitable mortgage by deposit of title deeds of the Company's immovable properties both owned and leasehold and building at Chadrihariarpur Kuarmunda, Sundargarh, Orissa and a first charge by way of hypothecation of the Company's moveable assets (save and except book debts) including machinery, machinery spares, tools and accessories, present and future subject to prior charges created and/or to be created in favour of the Company's bankers for securing working capital facilities. Loans are further secured by extension of equitable mortgage of landed properties at village Jugiana, Dist.- Ludhiana, Punjab, registered in the name of M/S Adhunik Steels Ltd, extension of equitable mortgage of landed properties at Jamshedpur, registered in the name of M/S Neepaz Tube (P) Limited ; Recurring Deposit Account in the name of the Company; Fixed Deposit in the name of the promoters / guarantors; corporate guarantee of M/S Adhunik Steels Ltd. and M/s Neepaz Tubes Pvt. Ltd. and personal guarantee of all the directors of the Company	20 quarterly instalments: 19 instalments of 47.00 lacs each & 20th instalments of Rs. 43.44 lacs
2	State Bank of India	12.25%	890.00	737.13		20 quarterly instalments: First 7 instalments of 40.00 lacs each, next 8 instalments of Rs. 45.00 lacs each and last 5 instalments of Rs. 50.00 lacs each. First instalment on 31.12.2004
3	State Bank of India	10.25%	5200.00	4,743.82		20 quarterly instalments of Rs. 260.00 lacs each. First instalment on 31.12.2005
4	Indian Oversease Bank	10.25%	2700.00	2,254.21		20 quarterly instalments of Rs. 135.00 lacs each. First instalment on 31.12.2005
5	State Bank of India	11.00%	400.00	403.74		20 quarterly instalments: First 2 instalments of 15.00 lacs each, next 4 instalments of Rs. 17.50 lacs each next 4 instalments of 18.50 lacs each, next 4 instalments of 21.50 lacs each, next 4 instalments of 22.50 lacs each and last 2 instalments of Rs. 25
6	Punjab National Bank	10.25%	1500.00	1,268.45		20 quarterly instalments of Rs. 75.00 lacs each. First instalment on 31.03.2006
7	State Bank of Mysore	10.25%	1100.00	1,041.40		20 quarterly instalments of Rs. 55.00 lacs each. First instalment on 31.03.2006
8	State Bank of India	12.10%	740.00	589.43		20 quarterly instalments of Rs. 37.00 lacs each. First instalment on 31.12.2004
<b>Total</b>			<b>13466.44</b>	<b>11,519.40</b>		
<b>B CASH CREDIT ACCOUNT</b>						
1	State Bank of India	11.75%	4670.00	4,181.33	The Cash credit and other working capital facility from banks are secured by the hypothecation of consumable stores, raw materials, finished goods, process stock , book debts (both present and future). Loans are further secured by extension of equitable mortgage of landed properties at village- Jugiana, Dist.- Ludhiana, Punjab, registered in the name of M/S Adhunik Steels Ltd, extension of equitable mortgage of landed properties at Jamshedpur, registered in the name of M/S Neepaz Tube (P) Limited ; Recurring Deposit Account in the name of the Company; Fixed Deposit in the name of the promoters / guarantors; corporate guarantee of M/S Adhunik Steels Ltd. and M/s Neepaz Tubes Pvt. Ltd. and personal guarantee of all the directors of the Company. The interest is	On Demand
2	Indian Oversease Bank	11.75%	750.00	734.70		
3	State Bank of Mysore	11.75%	250.00	236.18		
<b>Total</b>			<b>5670.00</b>	<b>5,152.21</b>		

## Annexure 14

## DETAILS OF UNSECURED LOANS

(Rs. in Lacs)

Particulars					As at 30th September	As at 31st December
	2002	2003	2004	2005	2005	2005
Security Deposit from Consignment Agents	-	-	266.50	383.00	498.00	380.00
Short Term Loan:						
From Bodies Corporate	-	-	10.00	20.00	31.00	36.00
From Banks	-	-	-	-	-	1,000.70
From Others	-	-	-	21.04	127.50	449.25
<b>Total</b>	-	-	<b>276.50</b>	<b>424.04</b>	<b>656.50</b>	<b>1,865.95</b>

## Annexure 14a

## Break up of Short Term Unsecured Loan as on December 31, 2005

Rs. In lacs

Particulars	Amount	Repayment Schedule	Rate of Interest	Interest Payment Schedule
From Promoters' Companies:	-	-	-	-
From Promoters Group Companies / Firm	-	-	-	-
From Others	485.25	On demand	10% - 16%	Half Yearly
From Banks	1000.70	Six Months from the date of disbursement	8.50%	Monthly

## Annexure 15

## Statement of Adjusted Other Income

Rs. In lacs

Particulars	Nature	For the year / period ended 31st March				31st December
		2002 (20.11.01 to 31.03.02)	2003	2004	2005	2005 (9 months)
Interest	Recurring	-	-	0.37	9.71	53.19
Unspent Liabilities and provision no longer required written back	Non-Recurring	-	-	1.09	5.50	13.48
Miscellaneous Income	Recurring	-	-	15.10	11.54	63.80
Profit on sale of Fixed Asset	Non-Recurring	-	0.03	-	-	-
Commission/brokerage Income	Non-Recurring	0.20	0.33	220.20	90.27	-
<b>Total</b>		<b>0.20</b>	<b>0.35</b>	<b>236.77</b>	<b>117.03</b>	<b>130.47</b>

**DETAILS OF INVESTMENTS**

Particulars	For the year / period ended 31st March				Rs. In lacs
	2002 (20.11.01 to 31.03.02)	2003	2004	2005	31st December 2005 ( 9 months)
	Long Term Unquoted - Other than Trade <b>In group companies</b> Equity Shares in Adhunik Meghalaya Steels Pvt. Ltd.	108.54	7.65	7.65	7.65
<b>Total</b>	<b>108.54</b>	<b>7.65</b>	<b>7.65</b>	<b>7.65</b>	<b>7.65</b>

**Annexure - 17****Sanctioned Working Capital Facilities**

Sl. No.	Name of the Bank	Fund Based	Non Fund Based			Total
			LC	BG	Total	
			1	State Bank of India	4670.00	
2	Indian Overseas Bank	750.00	500.00	300.00	800.00	1550.00
3	State Bank of Mysore	250.00	500.00	-	500.00	750.00
<b>Total</b>		5670.00	3000.00	600.00	3600.00	9270.00

*All significant Accounting Policies, Notes to the Accounts and Auditors Qualifications as provided in the Auditors Report dated February 24, 2006 have been incorporated as a part of the above statements.*

**Note:**

The term "Others" in Annexure 8a above (for the 9 month period ended 31<sup>st</sup> December, 2005) includes the following persons/entities:-

- a) Neepaz Tubes (P) Ltd.
- b) MP Ispat & Power Ltd.
- c) Adhunik Ferro Alloys Ltd.
- d) Pramila Agarwal
- e) Mohan Lal Agarwal
- f) Mahesh Kumar Agarwal
- g) Mahadeo Prasad Agarwal
- h) Ghanshyamdas Agarwal

## MANAGEMENT'S DISCUSSION AND ANALYSIS OF THE FINANCIAL CONDITION AND RESULTS OF OPERATIONS

### OVERVIEW OF THE BUSINESS OF THE COMPANY

Presently AML has manufacturing facilities for 2,50,000 tons per annum of carbon and alloy steel billets to cater the needs of various sectors of alloy and special steel. The existing manufacturing facilities of the Company are located at Rourkela, Orissa. The current production facilities of the Company are suitably integrated with sponge iron and pig iron making facilities. AML is emerging as one of the leading player in the alloy and special steels market in India. The Company has completed its first phase of project implementation comprising of Unit I and Unit II. The total cost of the project in Phase I was approximately Rs. 248 Crores which has been funded by the Company through promoters' contribution, internal accruals and bank loans. The existing production facilities of the Company and capacity-wise distribution of its current product range is summarized in the table below.

Module	Installed Capacity
Sponge Iron (100 x 5 TPD)	1,50,000 TPA
Blast Furnace (262 Cum)	1,80,000 TPA
Coal Washery	7,00,000 TPA
Steel Melting Shop consisting of EAF, LRF, Continuous Casting Machine & Captive Oxygen Plant	2,50,000 TPA
Captive Power Plant (12 MW) (expected commissioning by first quarter of 06-07)	73.44 Mu PA

The Company now proposes to embark on the 2<sup>nd</sup> phase of the project which would complete the integration of the product and process value chain of the Company.

#### *Phase II of the Project – Under Implementation*

In order to capitalize on the emerging opportunities in the auto-grade and engineering grade special/alloy steel and stainless steel markets, the Company has decided to set up various facilities so as to integrate its operations vertically and derive the benefits of synergy along the entire value chain.

The key facilities of phase II of the Project are summarized as under:-

Sl. No.	Division	Proposed Installed Capacity
1.	2 <sup>nd</sup> SMS with Vacuum Degassing Plant	1,56,300 MT per annum

2.	Rolling Mill	2,20,000 MT per annum
3.	Argon Oxygen Decarburization Plant	1,19,000 MT per annum
4.	Ferro Alloy Division	33,760 MT per annum
5.	2 <sup>nd</sup> Captive Power Plant	18 MW
6.	Sinter Plant	96,000 MT per annum
7.	Oxygen Plant	97,92,000 SM <sup>3</sup> per annum
8.	Bloom Caster	-
9.	Private Railway Siding	-
10.	Captive Iron ore & Coal Mines	-
11.	Billet/Bloom Conditioning & Roll Product Finishing	-

### ***Industry Scenario for Alloy and Special Steel***

In India there are 19 recognized alloy and special steel producers with an installed capacity of almost 2.8 million tones per annum and estimated production was 2.4 million tones in 2004-05. The India also imports a sizeable quantity of special and alloy steel. Out of the above, the operations of Visheswaria Iron & Steel Plant (VISP), SISCOIL and Kalyani Steel, are based exclusively on hot metal generated through MBF and solid scrap where as the production process in Sunflag Steel is based exclusively on sponge iron and solid scrap route. The operation of other recognized alloy and special steel producers are based on solid scrap based Electric Arc Furnace (EAF) and Induction Furnace technology. It may be noted that presently none of the players except Usha Martin Limited is making steel through the cost effective route of charging sponge iron and hot metal in the electric arc furnace. AML is positioning itself in the present scenario as the most cost effective producer of special and alloy steel.

### ***End Uses of the products***

The key end users of alloy and special steels include: steel forging industry, automobile and auto ancillary units, railways, antifriiction bearings, seamless steel tubes, hand tools, industry machinery, bright bar industry, wire drawing industry etc. Nearly 250 grades of alloy and special steels are manufactured by the existing industry. These can be categorized into the following broad grades and their domestic production:

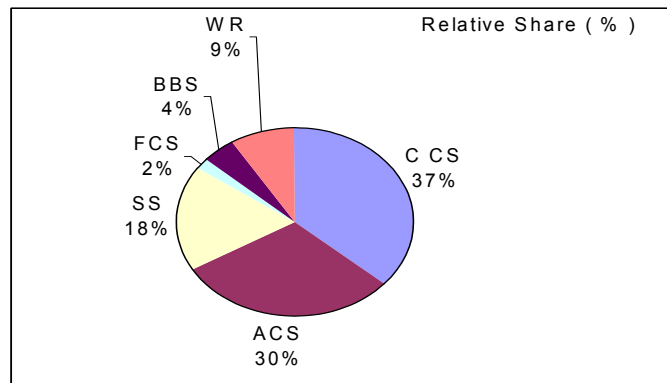

[CCS - Carbon Construction Steels, ACS- Alloy Constructional Steels, SS- Spring Steels. FCS- Free Cutting Steel, BBS- Ball bearing Steel, WR- wire Rods]

**End-use wise domestic demand for Alloy & Special Steels in 2004-05**

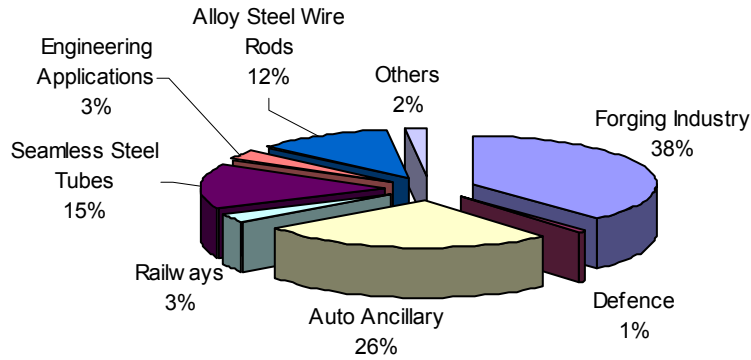

Source: Market Survey Report, IDSPL (December 2005), New Delhi

**Overview of the Global Market**

The global auto component market is currently estimated at \$1 trillion with OEMs accounting for 70% of this market and the balance being represented by the replacement market. By 2015, approximately 25-30% of the total requirement of auto components is expected to be sourced from low cost countries such as India, China, Brazil, Mexico, East Europe, etc. Indian manufacturers are now in a position to offer a complete range of engineering solutions including analysis & simulation, modeling & drafting, tooling design etc. India is fast becoming the preferred source for global OEMs and Tier-I vendors. A large amount of investment has already been planned by leading automotive players within India. [Source: Automotive Component Manufacturers Association of India (ACMA)]

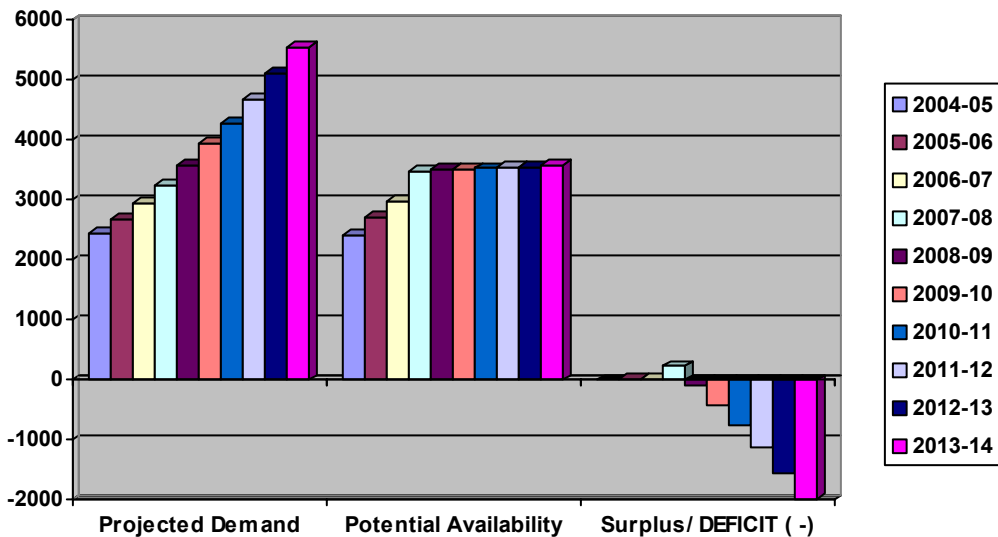

Source: Market Survey Report, IDSPL (December 2005), New Delhi

### ***India attractive v/s other outsourcing market***

Cost pressures are forcing global OEMs and Tier 1 suppliers to outsource from low cost manufacturing destinations. India is expected to leverage on its strong designing and engineering capabilities with a low-cost manufacturing base to emerge as a key outsourcing destination going forward. With global OEMs focusing on designing, assembly and marketing, outsourcing is gaining momentum. India scores over its peers such as Mexico, Brazil and China on designing, engineering and R&D capabilities. While Mexico, Brazil, Thailand and China are key auto component outsourcing markets for global auto OEMs, growth rates have slowed down with manufacturing cost rising. With global OEMs and Tier 1 suppliers having established purchase offices in India for outsourcing to its global plants, the growth potential for export from India is significant. The valuation of Indian component industry is attractive and expected to appreciate going forward. A recent survey by AT Kearney revealed that leading auto majors from US preferred offshoring jobs to India over China, Mexico and Brazil. India scored the highest vote for being the top offshoring destination with 24%, followed by China (15%), Mexico (13%) and Brazil (10%). Its costs competitiveness, good quality, superior engineering and technical skills largely gave it an edge over its peers.

### ***Where does India stand?***

<b>Parameters</b>	<b>India</b>		<b>Thailand</b>
	<b>1</b>	4	
ABILITY TO SUPPLY CONSISTENT QUALITY		4	2
	<b>4</b>		3
DESIGN AND ENGINEERING CAPABILITIES	<b>1</b>	4	3
CUSTOMER/AFTER SALES SUPPORT	<b>3</b>	4	1
MATURITY OF AUTO COMPONENT INDUSTRY		4	3
GOVERNMENTS REGULATIONS		3	1
ATTRACTIVENESS OF THE DOMESTIC MARKET		1	3
COMPLIANCE AND TRANSPERANCY		4	3
<b>TOTAL SCORE</b>		29	21

***Forst and Sullivan Ranks: lower the better***

***Source: Business World – 23 February, 2004***

*Domestic Demand Supply Scenario for Alloy & Special Steels: 2004-05 to 2013-14*

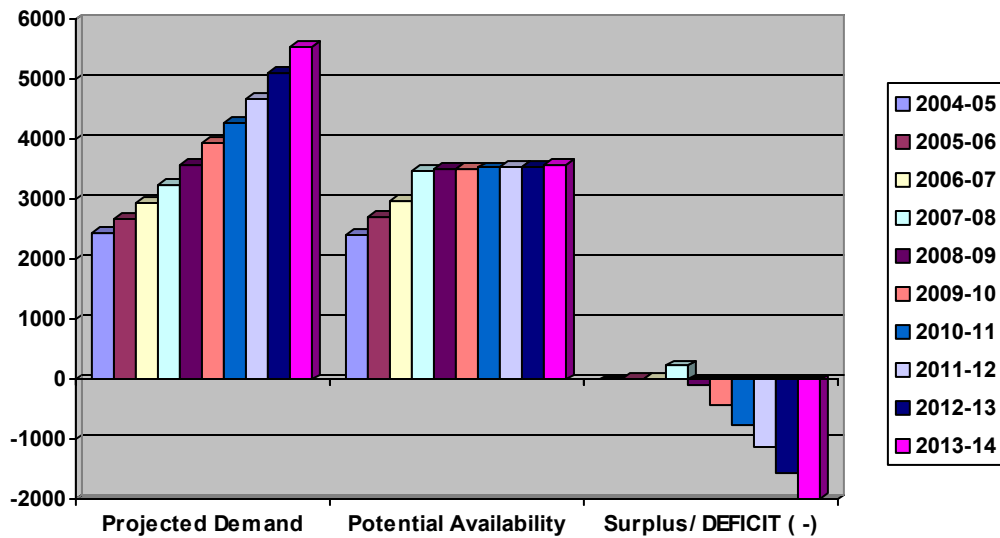

*Source: Market Survey Report, IDSPL (December 2005), New Delhi*

The above chart demonstrates that the availability of alloy and special steels in the country is likely to fall short of the requirements from 2008-09 onwards though more or less balanced as of now. The gap in the domestic availability is likely to increase to almost 1.6 million tones per annum by the year 2013-14. There appears good scope for a new entrant this industry so as to be in full production by the year 2008-09. Further there is a huge potential for export of steel for auto components globally. Indian share in global auto component market is growing at an exponential rate.

With stiff competition amongst OEMs and focus on cost rationalization the Indian auto industry is following the global outsourcing trend. Most Indian OEMs today source nearly 70-80% of their component requirement from vendors compared to 50-60% in the mid 1990s. Factoring this and growth phase in the Indian auto industry continuing following new entrants the domestic growth for auto component is strong. In a report by AT Kearney, the ACMA expects that the domestic auto component industry to grow by 15% CAGR till FY2012.

### *Geographical Distribution of Indian Auto Component Exports*

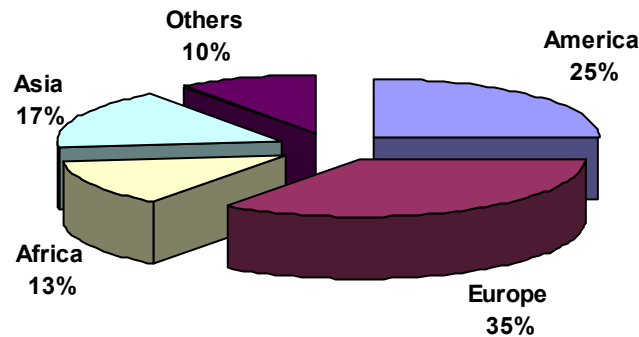

Source: Market Survey Report, IDSPL (December 2005), New Delhi and HDFC Sec. Research

### ***Positioning of AML in the Speciality Steel and Stainless Steel Segment***

AML is making steel through the most cost effective route of charging sponge iron and hot metal in the electric arc furnace. Further AML offers an entire range of value added special steel which with its cost benefits provides its an edge over the other competitors in the industry. As the group is in the steel business for three decades, AML leverages on these long term relationships with vendors and customers with tangible value propositions which represent our commitment for enhancement of stakeholder value.

#### **i) Strategic Focus**

With strong growth in domestic markets, export in ramp-up mode AML is working towards enhancing its capacity and to offer higher value added products. We have identified a growth oriented niche in the economy and have accordingly focused on the auto steel and engineering sector. The entire product portfolio of the Company is tailored for the auto & engineering Industry. The Company is focused on consolidation/integration of processes, low cost production, rationalization of supply chain, supplies to OEMs domestically and drastically. These would help the Company to increase its value of content.

#### **ii) Entry Barriers**

The major entry barrier that we believe is AML's cost advantage on account of vertical integration and our command over the complete value chain commencing from ore to finished products. Our effort to adhere to global standards would enable us to maintain leadership position in the niche in which we operate. Further the plant is located in Orissa, hub of raw materials and the State Government has decided to sign only mega MoU's. AML is well positioned to get its captive Iron ore mines as it was among the first few parties who have signed the MoU with State Government and completed the criteria for allotment.

#### **iii) Control over raw materials**

The plant is located in Orissa, hub of raw materials required for steel making. The Company has firm arrangements for supply of Iron ore and coal, key raw materials required for the steel industry. Further the Company has been allotted coal mines in Talcher area and allotment of Iron ore mine is at final stage. Apart from this, nation's 98% deposits of chromite ore, essential for manufacturing of Stainless Steel are in Orissa.

#### **iv) Integrated and location facilities**

Post implementation of the proposed expansion, AML will have an integrated plant starting from iron ore, coal to high value added stainless steel, special and alloy steel under single umbrella. Due to integration of all facilities the Company will be able to sustain any temporarily price fluctuation. Further the plant is strategically located in Orissa, hub of raw materials required for steel industry. All the sources of raw materials are situated within the range of 100-150 Kms from the plant. The plant is well connected with roads and rails.

#### **v) Domain Knowledge**

Our Promoters have been in the business of iron and steel for three decades and have extensive and in depth knowledge of the economic dynamics of the iron & steel market. Deep domain knowledge and experience has helped the Company in expanding its business and also to move up the value chain. The promoters have also long term business relationship with big players in the industry.

#### **vi) Strong Relationship**

The creation of customer value has been a top priority for AML and we have been able to build a clientele with both the suppliers and buyers and it comprises some of the leading names in the metallurgical market in India. We have delivered value to our customers by establishing partnerships in sharing short term and long term operational and strategic goals to enable them to achieve their business objectives.

#### **vii) Quality**

Our facilities are ISO 9001:2000 certified. Our quality process has been drawn largely from 5's concept of Total Productive Maintenance, Cause and effect diagram of "Ishikawa" is used to brainstorm out possible contributing causes of a particular problem or defect. Statistical process Control is used to get good quality during manufacture through prevention rather than detection. AML provides awareness training for operators in manufacturing to maintain unmatched quality of product.

We have a team of qualified, experienced and technically trained personnel to ensure strict adherence to global quality standards. The technical team operates in collaboration with a number of laboratories that provide reliable back up in terms of fast and accurate technical analysis. We use state-of-the-art equipment (like the Atomic Emission Spectrometer and SATMAGAN) for the purpose of detecting any flaw/anomalies in raw materials, intermediate products and finished products from the laid down standards. We work in close coordination with laboratories like RDCIS etc for high-level technical assistance whenever required. We also maintain regular interface with our customers to obtain feedback regarding possible areas of improvement both in the process and products.

Our sponge iron plant (which is one of the backward integration measures of our operations) has obtained ISO-9001: 2000 certification. We expect a similar certification for our Mini Blast Furnace and Steel Melting division by January 2006.

#### **viii) Customers**

The Company enjoys an illustrious list of customers that comprise prestigious names both in the public and the private sectors. Our clientele includes Steel Authority of India (SAIL), Tata Steel and other reputed players in the industry as well as a wide array of distributors and retailers in all over India. We have recently entered into several Memorandum of Understanding (MoU) with customers having approvals from leading OEMs in the automobile sector for supply of various grades of special and alloy steel products. The major of them are as follows:-

<b>Name of Party</b>	<b>Quantity of Off-take (tonnes per annum)</b>
Jai Parabolic Springs	40,000
Jamna Auto Industries Ltd.	40,000
JMT Auto Ltd.	18,000
Sharu Steel (P) Ltd.	18,000
R.L. Steels Ltd.	12,000
Arjan Das & Sons	10,000
CSIA Steels Pvt. Ltd.	5,000
Eknath Rolling Mills Pvt. Ltd.	4,000
Akar Tools Ltd.	3,500
V Cube Forge (India) Ltd.	3,500
Harig Crankshafts Ltd.	2,500

Apart from the above there are several other customers with whom the Company has also entered Memorandum of Understanding for supply of special steel and alloy steel products.

**SIGNIFICANT DEVELOPMENTS AFTER THE LAST FINANCIAL YEAR ENDED ON MARCH 31, 2005.**

The Company is in the process of setting up an integrated steel manufacturing unit. The entire project is being implemented in two phases. Unit I as disclosed on page no. 74 of the prospectus has already been completed as on March 31, 2005. Implementation of Unit II of the Project has been taken up during the current Financial Year 2005-06. All the facilities as described on page no. 75 of this PROSPECTUS except the Captive Power Plant have started operations. Other than this there have been no other significant developments after the FY 2004 –05 which may have a material impact on the financials of the Company.

## ANALYSIS OF FINANCIAL CONDITION AND RESULTS OF OPERATIONS

Audited financial details of our company for the past three years ended on March 31, 2005 and the nine months period ended December 31, 2005 are given below.

STATEMENT OF ADJUSTED PROFITS AND LOSSES				
				<i>Rs. In lacs</i>
	For the year / period ended 31st March			31st December
Particulars	2003	2004	2005	2005
				( 9 months)
<b>Income</b>				
<b>Sales:</b>				
Of products manufactured by the Company (Net of Excise Duty)	-	2,508.08	9,369.09	10,330.39
Of products traded by the Company	-	830.51	2,382.57	11,637.55
Conversion Charges ( Net of Excise Duty)		-	1,166.78	1,946.78
Other Income	0.35	236.77	117.03	130.47
<b>Total Income</b>	<b>0.35</b>	<b>3,575.36</b>	<b>13,035.47</b>	<b>24,045.19</b>
<b>Expenditure</b>				
Raw Materials & Goods Consumed including expenses on conversion job	-	1,789.49	6,503.38	6,124.19
Decrease/ (Increase) in Inventories	-	(620.96)	132.34	(65.53)
Purchase of Trading Goods	-	790.66	2,218.98	10,302.65
Personnel Cost	-	22.28	126.54	228.54
Other Manufacturing Expenses	-	291.54	1,073.72	2,332.47
Administrative and other expenses	0.24	109.41	317.21	329.61
Selling and Distribution Expenses	-	288.01	1,076.26	646.70
Interest	-	103.65	298.99	649.55
Depreciation	-	73.72	220.73	438.34
Preliminary Expenditure written off	0.07	3.80	3.83	2.88
<b>Total Expenditure</b>	<b>0.31</b>	<b>2,851.60</b>	<b>11,971.98</b>	<b>20,989.39</b>
<b>Net Profit Before Tax and Extraordinary Items</b>	<b>0.04</b>	<b>723.76</b>	<b>1,063.49</b>	<b>3,055.79</b>
<b>Provision for Taxation:</b>				
<b>Fringe Benefit Tax</b>	-	-	-	6.48
<b>Current Tax</b>	0.02	55.64	88.26	257.15
<b>Deferred Tax Liability / (Asset)</b>	-	257.54	265.40	1,110.89
<b>Net Profit after tax and before Extraordinary Items</b>	<b>0.02</b>	<b>410.58</b>	<b>709.83</b>	<b>1,681.27</b>
Extraordinary Items (net of tax)	-	-	-	-
<b>Net Profit after Extraordinary Items</b>	<b>0.02</b>	<b>410.58</b>	<b>709.83</b>	<b>1,681.27</b>
Earlier Year adjustments	-	-	-	-
<b>Appropriations</b>				
Balance brought forward from previous year	0.01	0.03	410.61	1,120.44
Transfer to General Reserve	-	-	-	-
Proposed Dividend	-	-	-	-
Tax on Proposed Dividend	-	-	-	-
Balance carried to Balance Sheet	<b>0.03</b>	<b>410.61</b>	<b>1,120.44</b>	<b>2,801.72</b>

### Notes:

(1) The above figures should be read with the Statement of Significant Accounting Policies and Statement of Notes on Adjusted Profits & Losses and Assets & Liabilities, as appearing in Annexure 4 and 5 respectively.

(2) Necessary adjustments have been made to the audited financial statements in accordance with the requirements of paragraph 6.10.2 of The Securities and Exchange Board of India (Disclosure and Investor Protection) Guidelines, 2000.

The above financials have been extracted from the financial statements prepared in accordance with Indian Accounting Standard, the Companies Act 1956, and other statutory acts and regulation as they are applicable and restated as described in the Auditor's Report of M/s. S. R. Batliboi & Co., Chartered Accountant in the section with the title "Financial Statements". The following discussion is based on our

audited financial statements (as restated) for the year period ended September, 2005, which have been prepared in accordance with Indian Accounting Standard, the Companies Act 1956, and other statutory acts as they are applicable. Our fiscal year ends on March 31<sup>st</sup> of each year.

The Company has commenced its commercial production in phase wise manner starting from September, 2003. Hence, the Management Discussion is being carried out for Fiscal 2005 vis-à-vis Fiscal 2004 and half year ended September, 2005 vis-à-vis Fiscal 2006.

### **COMPARISON OF FISCAL 2003 WITH FISCAL 2002**

The Company was in the process of implementing Phase I of the project and had not commissioned its plant upto the Fiscal 2003. As such , the Company has reported revenues out of other income to the extent of Rs. 0.0035 Crs. In absence of manufacturing operations during both the Fiscal 2003 and Fiscal 2002 a comparison of the financials will not be meaningful and hence has not been made

### **COMPARISON OF FISCAL 2004 WITH FISCAL 2003**

The Company started its manufacturing operations during the Fiscal 2004 with the commissioning of Unit I.

#### **Sales**

- a) Sales for Fiscal 2004 was Rs. 33.38 crores as compared to a nil income from sales during the Fiscal 2003. The main reason for this was the commissioning of the Unit I of Phase I of the project ( for further details please refer to page no 74 of this prospectus).

The Company is in the process of setting up an integrated steel plant in two phases. Out of this Unit I which was a part of Phase I of the project has become operational from this fiscal.

#### **Raw Material Expenses**

The cost of raw material consumed was Rs. 17.89 crores during Fiscal 2004 as compared to nil costs during Fiscal 2003 since there were no manufacturing operations during the Fiscal 2003.

#### **Manufacturing Expenses**

Manufacturing expenses of the Company comprise power & fuel, repairs & maintenance, stores & spares consumed, etc. The manufacturing expenses were Rs. 2.92 crores during Fiscal 2004.

#### **Personnel Cost**

Personnel cost for the Fiscal 2004 was Rs. 0.22 crores. During the Fiscal 2003 the Company did not incur any Personnel Costs since the Company has not started manufacturing operations.

#### **Selling & Administrative Expenses**

Selling & Administrative Expenses represent freight & forwarding expenses, commission paid to consignment/sole selling agents, insurance and other administrative expenses. The selling & administrative expenses for the Fiscal 2004 were Rs. 3.97 crores as against a nil expense towards this during Fiscal 2003.

### **COMPARISON OF FISCAL 2005 WITH FISCAL 2004**

#### **Sales**

Sales for Fiscal 2005 was Rs. 142.14 crores as compared to Rs. 39.75 crores in Fiscal 2004 (6 months' operation). The main reasons for the increase in total sales were:-

- b) expansion in DRI capacity – increase of DRI capacity from 60,000 tonnes per annum to 1,20,000 tonnes per annum
- c) Fiscal 2004 was taking into consideration only 6 months' operation.

The Company has been implementing its DRI project in phases and commenced operation in the first kiln in September, 2003. Subsequently, the Company has progressively increased its DRI capacity to 400 tpd (4 kilns) by March, 2005.

Capacity utilization figures have also increased during Fiscal 2005 as compared to Fiscal 2004.

#### **Raw Material Expenses**

The cost of raw material consumed was Rs. 65.03 crores during Fiscal 2005 as compared to Rs. 17.89 crores during Fiscal 2004. The primary reason for the variation in the absolute raw material cost was the increase in production of sponge iron and longer period of operation during Fiscal 2005.

It may, however, be noted that raw material prices as a percentage of sales have been almost stable. During Fiscal 2004 raw material cost as a percentage of sales was 45%. The corresponding figure has marginally increased to 45.75% during Fiscal 2005, mainly because of rise in raw material prices

#### **Manufacturing Expenses**

Manufacturing expenses of the Company comprise power & fuel, repairs & maintenance, stores & spares consumed, etc. The manufacturing expenses were Rs. 10.73 crores during Fiscal 2005 as compared to Rs. 2.91 crores during Fiscal 2004. The main reason for the substantial variation in manufacturing expenses was the increase in production of DRI and longer period of operation during Fiscal 2005.

However, as a percentage of sales, the Company's manufacturing expenses have remained more or less stable (7.33% in Fiscal 2004 as compared to 7.55% in Fiscal 2005) over the two periods under consideration. This has been achieved through rigorous cost control and usage efficiency measures in our operation.

#### **Personnel Cost**

Personnel cost for the Fiscal 2005 was Rs. 1.26 crores as compared to Rs. 22.28 lakhs during Fiscal 2004. This variation is mainly on account of the increase in the number of employees in the Company which was in line with the enhancement in the volume of production of the Company.

Further, the Company has had to recruit highly skilled and technically qualified personnel during Fiscal 2005 in the production, R&D and quality control departments. Hence, the personnel costs incurred by the Company during Fiscal 2005 has increased substantially.

As a percentage of sales, personnel cost has registered an increment from 0.56% to 0.89%. This is mainly on account of our efforts to ensure a more employee friendly environment in our Company in order to retain the requisite talent for our operations.

#### **Selling & Administrative Expenses**

Selling & Administrative Expenses represent freight & forwarding expenses, commission paid to consignment/sole selling agents, insurance and other administrative expenses. The selling & administrative expenses for the Fiscal 2005 were Rs. 13.93 crores as against Rs. 3.97 crores during Fiscal 2004. The variation in the above expenses can be attributed to the increase in the scale of operation of the Company during Fiscal 2005.

As a percentage of Sales, selling & administrative expenses have registered a decline from 10% in Fiscal 2004 to 9.8% in Fiscal 2005. This decline has mainly been achieved through tighter cost control and efficiency in operations.

**Interest & Finance Charges**

Interest & Finance Charges for Fiscal 2005 were Rs. 2.99 crores as compared to Rs. 1.03 crores during Fiscal 2004. The increase in the interest and financial charges during Fiscal 2005 was mainly on account of disbursement of fresh loans for the projects completed during the period.

However, interest and finance charges as a percentage of sales have registered a decline (from 2.61% to 2.10%) between Fiscal 2004 and Fiscal 2005. This reflects our ability to arrive at more economical arrangements with lenders.

**Profit Before Tax (PBT)**

PBT for Fiscal 2005 was Rs. 10.63 crores as compared to Rs. 7.24 crores during Fiscal 2004. The margins have not grown as compared to the increase in the volume of production as the markets have stabilized during the Fiscal 2005, whereas the markets were exceptionally buoyant for the steel industry during Fiscal 2004.

The reduction in margin can also be traced to the fact that the raw material prices were on the upswing.

## **COMPARISON OF NINE MONTHS PERIOD ENDED DECEMBER, 2005 WITH FISCAL 2005**

### **Sales**

Net sales for period ended December 31, 2005 (nine months) was Rs. 211.39 Crores as compared to Rs. 117.52 Crores in Fiscal 2005 (Full year operation). The annualized sales for the period have increased as compared to sales for Fiscal 2005. The main reasons for the increase in total sales were:-

- a) Expansion in DRI capacity – increase of DRI capacity from 120,000 tonnes per annum to 1,50,000 tonnes per annum.
- b) Commencement of commercial production of Mini Blast Furnace from September 2005
- c) Capacity utilization of the DRI kilns has increased on account of the Company's ability to use washed coal from its own coal washery and improvements in operating parameters in line with ISO 9000: 2001 standards.

### **Raw Material Expenses**

The cost of raw material consumed was Rs. 61.24 Crores during nine months period ended December 2005 as compared to Rs. 65.03 Crores during Fiscal 2005. The primary reason for the variation in the raw material cost was the decrease in consumption norms of few raw materials in production of sponge iron and decrease in raw material cost as compared to last fiscal. However, raw material expenses as a percentage of net sales have registered a decline (from 55.34% to 22.97%) between half year ended September 2005 and Fiscal 2005.

The economy in raw material cost has been achieved through modification of consumption norms whereby the iron ore fines which were earlier being sold in the open market are now being used for manufacturing DRI in the kilns.

Further, we have commenced using washed coal from our coal washery. This has also contributed to a reduction in the raw material cost as a percentage of sales.

Earlier we have been procuring iron ore from Joda area which is 140 km from our plant site. During the half year ended September 2005, we have been utilizing a firm linkage for coal with Mahanadi Coalfields Ltd. (MCL) and iron ore with Orissa Mining Corporation (OMC). Besides, we purchase our raw materials from MCL and OMC at subsidized rates on account of the quotas allotted to us.

We have started purchasing iron ore from OMC mines which are in close proximity to our plant. This has led to considerable logistic advantages.

### **Manufacturing Expenses**

The manufacturing expenses were Rs. 23.32 Crores during nine months period ended December 2005 as compared to Rs. 10.73 Crores during Fiscal 2005. The main reason for the variation in manufacturing expenses was the increase in production of DRI and commencement of operation of Mini Blast Furnace. Manufacturing expenses as a percentage of sales have registered an increase (from 7.55% to 9.06%) between Fiscal 2005 and nine months ended December 2005.

### **Personnel Cost**

Personnel cost was Rs. 2.29 Crores during nine months period ended December 2005 as compared to Rs. 1.26 Crores during Fiscal 2005. This variation is mainly on account of the increase in the number of employees in the Company which was in line with the enhancement in volumes for the Company.

Another reason for the increase in the personnel cost is that our Company has had to employ highly qualified professionals for our marketing and operations especially in view of the increase in the volume of production and increased sophistication in the nature of our products.

#### **Selling & Administrative Expenses**

The selling & administrative expenses during nine months period ended December 2005 were Rs. 6.47 Crores as against Rs. 13.93 Crores during Fiscal 2005. The variation in the above expenses can be attributed to the Company's policy of making direct sales to parties. As a percentage of sales, selling & administrative expenses have reduced substantially from 9.15% during Fiscal 2005 to 3.06% during nine months period ended December, 2005.

Further, till March 2005, our Company has been predominantly using road transport for incoming and outgoing logistics. During nine months period ended December, 2005, the Company has shifted to movement of goods by rail. This has led to significant economies in the logistic costs.

#### **Interest & Finance Charges**

Interest & Finance Charges during nine months period ended December 2005 were Rs. 6.50 Crores as compared to Rs. 2.99 Crores during Fiscal 2005. The increase in the interest and financial charges during nine months period ended December 2005 was mainly on account of disbursement of fresh loans for the projects completed during the period. However, interest and finance charges as a percentage of sales are almost at the same level (2.54% in Fiscal 2005 and 3.07% during nine months period ended December 2005).

Our Company has, during nine months period ended December, 2005 managed to negotiate favourable rates with its working capital bankers. This has led to savings in interest cost in relative terms.

#### **Profit Before Tax (PBT)**

PBT for the nine months period ended December 2005 was Rs. 30.56 Crores as compared to Rs. 10.63 Crores during Fiscal 2005. The PBT margin on sales has also grown (from 7.48% in Fiscal 2005 to 11.87% during the nine months ended December 2005).

The improvement in the PBT margin has been achieved mainly through control over raw material costs, logistics costs and an improvement in the product mix in favour of high value added items.

#### **LIQUIDITY AND CAPITAL RESOURCES**

We depend on both internal and external sources of liquidity to fund working capital and capital expenditure. For external funding, we have relied on bank finance. Our current banking arrangements are as follows:-

<b>AMOUNTS</b> <i>(in Rs. Lakhs)</i>	<b>FUND BASED LIMIT</b>	<b>NON FUND BASED LIMIT</b>	<b>TOTAL</b>
Working Capital Limits	5,670	3,600	9,270
Term Loans	12,971	-	12,971
<b>TOTAL</b>	<b>18,641</b>	<b>3,600</b>	<b>22,241</b>

#### **Information required as per Clause 6.10.5 of SEBI Guidelines.**

##### **Unusual or infrequent events or transactions**

There are no unusual or infrequent events or transactions that have significantly affected the business of our Company.

**Significant economic changes that materially affected or are likely to affect income from continuing operation.**

- ❖ The custom duty on coking coal-having ash content greater than 12% has been reduced from 15% to 5%, which will benefit our business.
- ❖ The implementation of Value Added Tax (VAT) which replaces local sales taxes will have a positive impact on our business.
- ❖ Booming Auto ancillary sector will have a positive impact of the Company.
- ❖ Thrust on infrastructure i.e. building roads, ports, airports, rails, etc will benefit us as steel forms the basic raw material for such infrastructure development.
- ❖ The proposal to allow 100% Foreign Direct Investment in the construction sector will provide an impetus to the industry.

**Known trends or Uncertainties**

Uncertainty exists over the availability and prices of our raw materials namely Iron Ore, Coal etc, and finished product viz. Sponge Iron, Pig Iron, Alloy Billets etc. The risk on account of the above price fluctuation will be reduced significantly after the Company starts the captive coal & iron ore mines. Extent considering the fact that a rise in the price of basic raw material will be passed on in the form of increased price of the finished products.

**Future relationship between costs and income**

Import duty on raw materials like iron ore, coke coal etc. excise duty on steel and introduction of VAT are the three important factors, which would materially affect cost as a percentage of revenue. The commissioning of the Captive Power Plant shall significantly reduce the cost of power and the ratio of cost to sales would significantly improve.

**Reasons for material increase in net sales or revenue**

The material increase in sales revenue is on account of full year of operation of Sponge Iron kilns and operation of one Mini Blast Furnace, Steel Melting Shop, for the entire year under consideration as compared to operations for only a part of the year in FY 2003-04. Our Company has also been able to achieve a quantum jump in reduction of variable cost by implementing various cost cutting measures.

**Total turnover of each major industry segment in which the Company operates**

The Company operates in a single segment. Therefore, separate segment reporting is not required.

**New Products or business segments**

The plant is equipped to make Value Added Products conforming to various standards and as per user choice. The range includes high, medium and low carbon steel, free cutting steel, low alloy steel, high alloy steel, spring steel, bearing steel etc. to meet the requirements of Automobiles sector, Construction Sector, Engineering Sector.

The Company has recently entered into several Memorandum of Understanding (MoU) with customers having approvals from leading OEMs in the automobile sector for supply of various grades of special and alloy steel products. The various grades of products and their end use in which we are dealing are as under:

Category	Application / End Use
Low Carbon	Forging
Plain Carbon	Automobiles / Engineering
Carbon Construction Steel	Automobiles
Cold Forging	High level fasteners and safety equipments
Alloy Construction Steel	Automobiles, Forging
Spring Steel	Leaf Spring
Free Cutting	Bright Bar for Auto & Engg. Industries

Apart from these we also sell sponge iron and pig iron which left out after meeting our captive requirements. We have also commissioned a Coal Washery and in the process of setting up a 12MW non conventional Captive Power Plant. We are committed to focus on further brand awareness and quality improvement of our product in the times to come.

#### **Seasonality of business**

Our business is not seasonal.

#### **Dependence on single or few suppliers/customers**

- ❖ Currently there are many suppliers of iron ore and coal in India and dependence on few suppliers is not likely to occur. Moreover, the Company has already entered into long-term understanding for supply of iron ore with The Orissa Mining Corporation Ltd.(OMC), The Orissa Minerals Development Corporation Ltd. (OMDC). We have also got linkages for coal from Mahanadi Coal Fields Limited (MCL).
- ❖ Our Company sells its product through various dealers in all over India and dependence on single or few customers is non-existent.

#### **Competitive Conditions:**

The Company is suitably placed to have a competitive edge over its competitors owing to the following reasons:

- ❖ Integrated Steel Plant with captive power generation out of waste heat & gas which is both cost effective and environment friendly.
- ❖ Assured supply of iron ore through long-term supply arrangements. The Company has already applied for coal blocks and iron ore blocks in the state of Orissa/Jharkhand for meeting its raw material requirements.

- ❖ By setting up a Captive Power Plant which will produce power through non-conventional resources Company will qualify for CDM (Clean Development Mechanism) benefits. CDM is a mechanism by which Industrialized Nations can achieve part of their reduction obligations through projects that reduce or fix/sequester carbon in Developing Countries.
- ❖ Approval received from the Ministry of Environment and Forests for Clean Development Mechanism.
- ❖ Substantial in-house capacity for production of both Sponge Iron and Pig Iron
- ❖ Captive Power generation for steel melting is in implementation.
- ❖ Market reputation of the promoters
- ❖ The fragmented structure of the sector possesses a good opportunity for a medium/large industry house to distinguish itself from the lot and create a position of strength by having a diversified product mix and a varied product penetration along with the necessary infrastructure for quality production.

The Directors confirm that, there have been no events or circumstances since the date of the last financial statements, which materially and adversely affect or are likely to affect the profitability of the Company or the value of its assets or its ability to pay its liabilities within the next twelve months.

## **OUTSTANDING LITIGATION AND MATERIAL DEVELOPMENTS**

Except as described below, there are no outstanding litigation, suits or criminal or civil prosecutions, proceedings or tax liabilities against the Company, our Directors and our group companies that would have a material adverse effect on our business and there are no defaults, non-payment or over due of statutory dues, institutional/bank dues and dues payable to holders of any debentures, bonds and fixed deposits that would have a material adverse effect on our business other than unclaimed liabilities against the Company or Directors or our group companies as of the date of this Prospectus.

### **A. Contingent liabilities not provided for as of 30<sup>th</sup> September, 2005 are as follows:**

As of December 31, 2005, the contingent liabilities, not provided for, are enlisted in the following table. If these contingent liabilities materialise, fully or partly, AML's financial condition could be adversely affected.

<b>Particulars</b>	<b>Amount (Rs. in Lacs)</b>
Claims against the Company not acknowledged as debt.	54.56
Outstanding Bank Guarantee and Letter of Credit for import of material	186.50
Corporate Guarantees issued to Banks on behalf of group companies	200.00
<b>Total</b>	<b>441.06</b>

### **B. Litigation against the Company:**

#### **1. Public Interest Litigation**

Sanjay Kumar Sahoo, Secretary, Mr.Loknath Jala and Parimala Samiti had filed a public interest litigation ("PIL") in the High Court of Orissa at Cuttack against the Managing Director, M/s Neepaz Metaliks Ltd and others (**W.P. (C) No. 8742 of 2005**)

This application was filed to direct our Company to lay pipelines for use of water from river Sankha instead of River Koel and to lay the pipelines separately from the pipelines of the Village Water Sanitation Committee Pipes and to install dust and smoke control machinery prior to operation of the sponge iron factory.

Miscellaneous Case No. 8690 of 2005 arising out of W.P. (C) No. 8742 / 2005 was filed by Sanjay Kumar Sahoo for stay of the construction of pipelines.

The High Court of Orissa has passed an order dated July 27, 2005 dismissing the writ application stating that the same is not maintainable against the Company being a private company.

#### **2. Writ Petition**

This matter is pending before the High Court of Orissa and is to come up for hearing on September 23, 2005 according to the last order passed by the court.

Rashmi Ranjan Mundull had filed a writ petition (**W.P. (C) No. 8371 of 2005**) and an application for stay (**Misc Case NO. 8318 of 2005**) against Secretary to Government, Water Resources Department and others wherein the Company is the fifth respondent, in the High Court of Orissa.

This petition has been filed in the nature of a public interest litigation, challenging the permission granted by the Water Resources Department, Collector, Chief Engineer, Lift Irrigation Department and Executive

Engineer, National Highways Division to our Company to take water through a pipeline from the lift irrigation project which was duly constructed by the State Government for a dairy farm irrigation and for irrigation of other agricultural land. The petitioner further prayed that the Company be directed not to draw water from the Lift Irrigation Project and to shift the pipes layed down.

It appears from the copy of the orders passed by the Orissa High Court that the petitioners have entered appearance on July 5, 2005, when the court has directed the petitioner to issue notice to the opposite parties by registered post A.D. returnable within two months.

The Company has appeared through its advocates on July 17, 2005 and prayed for time which was granted and the case was listed for admission for the next week.

On July 19, 2005, the counsel for the State entered appearance and requested for the matter to be listed after two weeks for admission, which was granted.

On August 9, 2005 the Hon'ble High Court of Orissa passed an order to list the case ten days after to enable the Additional Government Advocate to file counter affidavit.

The matter came up on August 23, 2005 when the Hon'ble High Court of Orissa ordered the matter to be listed one month after for admission as prayed for.

### **3. CIVIL SUIT**

#### **a) Civil Misc Application No. 39 of 2005 in C.S. No. 128 of 2005**

Bijoy Pratap Singhdeo filed a suit and an application under order 39 rule 1 and 2 of the Code of Civil Procedure against M/s. Neepaz Metaliks Ltd (Civil Misc Application No. 39 of 2005 in C.S. No. 128 of 2005) before the Civil Judge (Senior Division) Rourkela for declaration of right, title and interest over the suit Adi (embankment), permanent injunction restraining from lay pipeline over the suit Adi and mandatory injunction to pull down the pipe lines if the same is laid during the pendency of the suit..

The court by its order dated July 23, 2005 directed that status quo be maintained with respect to the suit Adi until further orders and directed the Company to show cause July 29 2003 as to why the status quo should not be made absolute.

A summon for settlement of issues dated July 23, 2005 was issued to the Company summoning the representative to appear in court on August 18, 2005 to answer questions and claims relating to the suit.

The court passed an order dated September 3, 2005 restraining the company by way of ad interim injunction from interfering or diturbing the suit embakment in any manner till disposal of the suit.

An appeal has been preferred against the aforesaid order in the High Court of Cuttack bearing number FAO 392 of 2005.

#### **b) C.M.A. No. 18 of 2005**

Shiba Ram Water & Sanitation Committee ("Petitioner") filed an application under Order 39 rule 1 & 2 of the Code of Civil Procedure seeking a temporary injunction against our Company thereby restraining our Company from disturbing or cause hindrance to the water supply system of the Petitioner by the laying of water pipelines in close proximity of that of the Petitioner. Our Company contested the petition stating inter alia that the Court has no jurisdiction and the Petitioner has no locus standi and denying the allegations in the petition.

The Court of the Civil Judge (Jr. Div) Rourkela passed an order on July 6, 2005 whereby it did not grant any temporary injunction as prayed for, however directing our Company to take precautionary measures not to damage the pipelines of the Petitioner while laying its pipelines and thus disposed off the petition.

## CASES BY STATUTORY AUTHORITIES

### 4. SALES TAX/ENTRY TAX

**Assessment year : 2002-2003**

**Demand: Rs 6,11,700.00/-**

The Company had purchased goods like support kiln, old used dumper, spare parts of 100 TDB kiln, clamping flange, cooler shell parts, gear ring etc from TISCO for an amount of Rs 2,52,84,932.00/- and admitted entry @ 1% claiming the goods to purchased as scrap materials (machinery and spares). However the STO did not accept the claim since machinery and spares falls under Schedule-II of Entry Tax Act and hence are to be taxed @ 2%. Accordingly entry tax @ 2% was levied. The STO further added 5% on the purchase value towards freight charges. This led to a dispute and the company filed an appeal before the ACST against the order of assessment under section 7(4) of the Orissa Entry Tax Act by the STO.

The ACST on hearing the submission of the Company confirmed the order of assessment thereby dismissing the appeal, stating that the goods purchased are machinery and spares to be taxed @ 2% and further that since the Company had failed to produce any evidence regarding the actual amount of freight paid in transporting the goods, the levy of freight charges was in order.

Our Company has filed an appeal before the Sales Tax Tribunal as also an application for revision before the Commissioner of Commercial Taxes both on September 30, 2005 against the order of the ACST dated July 22, 2005. The revision application sought for an interim stay on the recovery of the demand disputed upon till the hearing and disposal of the second appeal.

### 5. EXCISE

**a) Demand: Rs 15,13,629 ( Rs 14, 82,980/- on input credit + Rs 30, 649/- on capital goods credit)**

The Office of the Commissioner, Central Excise & Customs, Bhubaneswar – II issued a demand – cum- show cause notice dated April 20, 2004 to the Company for having contravened the provisions of Rule 2,3 and 7 of the CENVAT Credit Rules 2002 read with section 2 (F) of Central Excise Act, 1944, in as much as they have irregularly availed input CENVAT Credit of Rs 14,82,980/- on plates, angles, channels, joists, beams, coils and other structural items and welding electrodes etc. and CENVAT Credit of Rs 30,649/- on aluminum coil sheets and welding electrodes as capital goods during the period from July 2003 to November 2003 with an intent to utilize such irregular credits towards payment of Central Excise duty on their final product viz. Sponge Iron.

The Company filed its reply dated May 20, 2004 to the show cause notice denying the allegations contained therein and requesting for a personal hearing before the matter is finally adjudicated upon.

A personal hearing was held on September 29, 2004 before the joint commissioner, central excise and customs and submitted a written statement wherein it was *inter alia* stated that as per the chapter 5 of the CBE & C Manual that, “*CENVAT should not be denied if the inputs are used in any intermediate of the final product even if such intermediate is exempt from payment of duty. The basic idea is that CENVAT credit is admissible so long as the inputs are used in or in relation to the manufacture of the final products, and whether directly or indirectly.*”

Upon adjudication, the joint commissioner passed an order on May 16, 2005 dropping the proceedings initiated by the show cause notice dated April 20, 2004 stating that the same does not survive on merits

as input credit taken on plates, angles, channels, joists, beams, coils, iron castings, aluminium coil sheets as capital goods are eligible to CENVAT credit.

**b) Total Demand of short payment: Rs. 13, 75, 101/- of central excise duty and Rs 27,502 of education cess for the period August 2004 to April 2005.**

The Directorate General of Central Excise Intelligence, Kolkata Zonal Unit issued a show cause notice No. DGCEI No. 155/KZU/RKL/05/1028 dated July 18, 2005 to the Company for under valuation of sponge iron and resultant short payment of duty.

An investigation was conducted at the factory and office premises of the Company and the residential premise of its directors Mohan Agarwal on May 27, 2005, when some incriminating records were recovered and seized under Panchanama.

The records revealed that Tata Steel issued purchase orders from time to time according to which iron ore delivered free cost at their mine pit head and the Company would transport the same at their Works at their own costs.

For the purpose of payment of central excise duty the selling price was taken at Rs 10,0000/- METRIC TONNE.

The Central Excise Valuation (Determination of Price of Excisable Goods) Rules, 2000 provides that the all costs including the cost of transporting the inputs to the job worker's premise plus the job worker's profit would form part of the value of the good.

On a critical examination it was noticed that the landed cost of the iron ore procured from M/s Tata Steel mines was not taken correctly as a result there has been under valuation and resultant short payment of duty.

Accordingly the Company is liable under section 11A of the Central Excise Act, 1944 as also liable for penalty under section 11AC and interest under section 11AB *ibid*. The Company has also violated the provisions of Rule 6 of the Central Excise Rules 2002 in as much as they have failed to correctly assess the duty on sponge iron supplied to M/s. Tata Steel.

Mr. Rathi, Chief Accounts Officer of the Company being the person responsible for accounting of freight charges has over looked the reimbursement of the same by Tata Steel for the purpose of valuation of sponge and thus is liable for penalty under Rule 26 of the Central Excise Rules 2002.

Our Company filed its reply on August 25, 2005 denying the allegations contained in the show cause notice and stating that the CENVAT credit on inputs was not taken into account while calculating the assessment amount. The Company requested for a personal hearing before the matter is finally adjudicated upon.

**c) Demand for Rs 5,45,007/- for irregular CENVAT credit.**

The office of the Commissioner, Central Excise & Customs, Bhubaneswar – II issued a demand – cum- show cause notice dated January 3, 2005 to the Company for having contravened the provisions of Rule 2,3 and 7 of the CENVAT Credit Rules 2002 read with section 2 (F) of Central Excise Act, 1944, in as much as they have irregularly availed input CENVAT Credit of Rs 5,45,007/- on plates, HR plates, Def. Plates, GC sheets, SS sheets, Ms coils, welding electrodes etc as input during the period from December 2003 to March 2004 with an intent to utilize such irregular credits towards payment of Central Excise duty on their final product viz. Sponge Iron.

Our Company filed a reply to the show cause notice vide letter dated March 3, 2005 disputing the contentions of the said show cause notice. The reply stated *inter alia* that the items on which input

credit has been availed cannot be considered as structural items as the said items are intermediate goods used in relation to the final product.

**d) Demand for Rs 1,63,303 for irregular CENVAT credit.**

The office of the Deputy Commissioner, Central Excise & Customs, Rourkela– I issued a demand – cum- show cause notice dated November 21, 2005 to the Company for having contravened the provisions of Rule 2,3 and 7 of the CENVAT Credit Rules 2002, in as much as they have irregularly availed input CENVAT Credit amounting to Rs 1,63,303/- on coal tar tapes, synthetics/chlorinated primer during the period from June 2004 to March 2004 with an intent to utilize such irregular credits towards payment of Central Excise duty on their final product viz. Sponge Iron.

Our Company has requested for an extension for a period of one month to file reply to the show cause notice vide letter dated December 21, 2005.

**e) Demand for Rs 23,214 for irregular CENVAT credit.**

The office of the Deputy Commissioner, Central Excise & Customs, Rourkela– I issued a demand – cum- show cause notice dated November 21, 2005 to the Company for having contravened the provisions of Rule 2 of the CENVAT Credit Rules 2002, in as much as they have irregularly availed input CENVAT Credit amounting to Rs 23,214/- on welding equipment during the month of November 2004 with an intent to utilize such irregular credits towards payment of Central Excise duty on their final product viz. Sponge Iron.

Our Company has requested for an extension for a period of one month to file reply to the show cause notice vide letter dated December 21, 2005.

**6. ORISSA POLLUTION CONTROL BOARD**

The Collector, Sundargarh alongwith the Sub-collector, Panposh and other Magistrates conducted a surprise inspection of the sponge iron plant of our Company on January 20, 2005, to ascertain the status of pollution control measures and its operation. Upon inspection the Collector made an observation that though all 4 ESPs were operated, profuse emission from the common stack of ESP of kiln I & II were observed. The Collector directed our Company to close down the operation of kiln I & II till the problems in both the ESPs are rectified to ensure their performance in compliance to emission norms of the State Pollution Control Board, Orissa (“Board”). Pursuant to the aforementioned surprise inspection, the Board, issued a show cause notice dated March 7, 2005 bearing no. 7515/Ind-I-Con-3285 enumerating the non-compliance in the operation of the sponge iron plant and directing to show cause within seven days as to why the consent to operated granted to the sponge iron plant of our Company should not be revoked and a direction of closure should not be issued to stop operation of the plant till the violations are complied with to the satisfaction of the Board. The show cause notice further provided for a personal hearing within the stipulated seven days.

Our Company responded to the aforesaid show cause notice by letter dated March 18, 2005 bearing no. NML/BBS/318/2005, enumerating therein the measures taken by the Company to ensure that the plant operates within the prescribed compliances and well below the emissions standards and the additional preventive measures to further reduce pollution, thereby stating that since all the violations pointed out have been rectified as such there lies no cause of action.

A personal hearing was conducted in the matter on March 18, 2005, when Board agreed to allow our Company to operate the 4\*100 TPD kilns subject to the filing of an affidavit by the Company undertaking rectification of the alleged violations. The Company accordingly, submitted under letter dated March 24, 2005 an affidavit affirmed by Mr. Manoj Kumar Agarwal, Managing Director on

March 22, 2005 stating that the necessary violations have been remedied by our Company. Subsequently, the Board granted renewal consent order No.WPC/1559.

## **7. ARBITRATION**

Our Company had entered into a contract dated July 28, 2005 for the purchase and import of low ash metallurgical coke of China origin from Express Well International Ltd.

Express Well International Ltd. sent an arbitration notice dated December 12, 2005 as the terms of the contract necessitated a letter of credit to be established by our Company to enable Express Well International Ltd. to affect the shipment from China to India, which was not established by our Company due to which disputes arose whereby Express Well International Limited alleged losses suffered claiming an amount of USD 2,70,000 .

Upon several discussion on settlement of issues between our Company and Express Well International Ltd. we received a letter dated December 30, 2005 from Express Well International Ltd. agreeing to pre-arbitration, conciliation and negotiation and settling the matter in an amicable manner.

However, Express Well International Limited filed an arbitration petition under section 11(5) and 11(6) of the Arbitration and Conciliation Act, 1996 read with rule 2 of the Appointment of Arbitrators Scheme, 1996 before the Supreme Court of India on or about February 7, 2006 for the appointment of an arbitrator.

### **Material Developments**

In the opinion of the Board of our Company, there have not arisen, since the date of the last financial statements disclosed in this Prospectus, any circumstances that materially or adversely affect or are likely to affect the profitability of our Company taken as a whole or the value of its consolidated assets or its ability to pay its material liabilities within the next 12 months.

## **Litigation against Our Directors**

Our Directors have no outstanding litigation towards tax liabilities, criminal/ civil prosecution for any offences (irrespective of whether they are specified under paragraph (i) of Part 1 of Schedule XIII of the Companies Act), disputes, defaults, non payment of statutory dues, proceedings initiated for economic offences, in their individual capacity or in connection with our Company and other companies with which the Directors are associated, except as below:

### **Pending Litigation and Contingent Liabilities pertaining to our Promoter Group Companies**

#### **A. Contingent liabilities not provided for as of 31<sup>st</sup> March, 2005**

None of the Promoter Group Companies have any contingent liabilities not provided for as on 31<sup>st</sup> March, 2005.

#### **B. Pending Litigation against Promoter Group Companies:**

##### **1. PETITION UNDER THE ARBITRATION AND CONCILIATION ACT 1996**

M/s. Adhunik Steels Limited (one of the group companies) had filed a petition (ARBP No. 52 of 2004) under section 11(6) of the Arbitration And Conciliation Act 1996 for the appointment of arbitrator against Orissa Manganese and Minerals Private Limited in the High Court of Orissa.

Disputes had arisen pursuant to an agreement between M/s. Adhunik Steels Limited and Orissa Manganese and Minerals Private Limited which has led to arbitration proceedings.

The Hon'ble High Court of Orissa has passed an order on August 12, 2005 directing issue of notice to the opposite party by speed post A.D. returnable in 6 weeks and the petitioner to file requisites by August 16, 2005.

This matter is pending and yet to be listed before the Hon'ble High Court of Orissa.

##### **2. ARBITRATION PETITION**

This matter is pending hearing before the High Court of Calcutta pursuant to the stay petition filed by M/s. Futuristic Steel Private Limited against the order of a single bench of the High of Calcutta.

M/s. Futuristic Steel Private Limited (one of the group companies) filed a stay petition (G.A. no. of 2005 in APOT No. 436 of 2004 in AP NO. 63 of 2004) against an order dismissing an application filed by M/s. Futuristic Steel Private Limited to restrain Orissa Manganese and Minerals Private Limited from affecting M/s. Futuristic Steel Private Limited right to purchase manganese ores agreed upon and granted by Orissa Manganese and Minerals Private Limited by agreement dated May 14, 2003 entered into by and between Orissa Manganese and Minerals Private Limited and M/s. Futuristic Steel Private Limited.

M/s. Futuristic Steel Private Limited by the said application sought the following reliefs:

1. Injunction restraining Orissa Manganese and Minerals Private Limited from committing any breach of the agreement dated May 14, 2003;
2. Injunction restraining Orissa Manganese and Minerals Private Limited from appointing anybody for selling any manganese ores. If necessary appointing a receiver over the said manganese ores.

Orissa Manganese and Minerals Private Limited had entered into an agreement with Adhunik Steels Limited dated May 14, 2003 and appointed them as the exclusive raising contractor for the mining activities and with M/s. Futuristic Steel Private Limited on even date for selling the manganese ores raised by Adhunik Steels Limited exclusively to M/s. Futuristic Steel Private Limited.

Orissa Manganese and Minerals Private Limited terminated the aforesaid agreements, stating that the same are in violation of the Mineral Concession Rules 1960 and void. Further, demanding a sum of Rs 33,90,000 with interest @ 2% per month with quarterly rests and also forfeiture of the amounts already paid by M/s. Futuristic Steel Private Limited to Orissa Manganese and Minerals Private Limited.

Futuristic Steel Private Limited invoked the arbitration clause in the agreement as also filed an application under section 9 of the Arbitration and Conciliation Act, 1996 seeking for injunctive reliefs against Orissa Manganese and Minerals Private Limited inter alia restraining them from preventing Futuristic Steel Private Limited from purchasing the manganese ores as per the said agreement, restraining them from terminating the said agreement and restraining them from selling the ores to anyone else, which as stated above was dismissed by the High Court of Calcutta.

The order dated May 21, 2005 of the High Court of Calcutta dismissing the said application states that no case has been made out for the injunction as prayed for and since the cheque presented for payment of the deposit made by Futuristic Steel Private Limited was dishonoured, they were not in a position to make payments.

The matter has neither been listed nor heard till date.

#### **4. SPECIAL LEAVE PETITIONS**

##### **a) Special Leave Petition No. 7165 of 2005**

Adhunik Steels Limited (one of the group companies) filed a special leave petition (“SLP”) (SLP No. 7165 of 2005) from order dated March 18, 2005 passed by the High Court of Orissa in Arbitration Appeal No. 26/04 against Orissa Manganese and Minerals Private Limited.

Adhunik Steels Limited was appointed as raising contractor in terms of the agreement dated May 14, 2003 entered into with Orissa Manganese and Minerals Private Limited. The said agreement was for a period of 10 years and on termination of the same earlier than the stipulated period gave rise to a dispute and Adhunik Steels Limited invoked the arbitration clause in the agreement by filing an application under section 9 of the Arbitration and Conciliation Act, 1996 seeking for interim measures of protection before the High Court of Calcutta on February 5, 2004. The Calcutta High Court by order dated February 9, 2004 granted injunction in favour of Adhunik Steels Limited to maintain status quo in respect of the excavation of the mines. The said order was modified by order dated March 12, 2003 restraining Orissa Manganese and Minerals Private Limited from disturbing the possession and creating any third party rights in respect of the said mines. However, the said petition under section 9 was dismissed on the grounds of lack of territorial jurisdiction by order dated May 20, 2004.

Thereafter, Adhunik Steels Limited moved the District Court of Sundergarh at Orissa, when the said court passed an order on June 24, 2004 directing the parties to maintain status quo. Ultimately the district court vide its detailed judgment and order dated August 18, 2004 restrained the respondents from terminating the agreement or from dispossessing the petitioner.

The respondents moved the High Court of Orissa against the aforesaid order being Arbitration Appeal no. 26/04. The High Court even though holding that the balance of convenience lied in favour of the petitioner did not affirm the judgment of the district court on the sole ground that the petitioner has been unable to prove that loss on termination of the agreement cannot be compensated in terms of money, thus setting aside the order of the district court dated August 18, 2004.

Hence the present SLP was filed against the order of the High Court of Orissa in Arbitration Appeal No. 26/04.

The Hon’ble Supreme Court has passed an order on April 15, 2005 to issue notice on the SLP and on the prayer for grant of interim relief. Direction for filing affidavits and rejoinder were given as four weeks and three weeks thereafter respectively. It was further directed that status quo is to be maintained.

The Supreme Court has passed an order on October 24, 2005 listing the matter on January 10, 2006 before the appropriate bench for appointing a date of hearing. It was further directed that the application for renewal of the lease by Orissa Manganese and Minerals Private Limited be kept pending during the hearing of the appeals and the time lost between the date of the application and the date of the decision in the appeals shall not be counted against Orissa Manganese and Minerals Private Limited.

##### **b) Special Leave Petition (Civil) No. 1430 of 2005**

Orissa Manganese and Minerals Private Limited has filed a SLP (SLP No. 14530 of 2005) from order dated March 18, 2005 passed by the High Court of Orissa in Arbitration Appeal No. 26/04 against Adhunik Steels Limited

This SLP was filed for allowing the petitioner to excavate, operate and manage the mines as the petitioners are the original lessees of the State Government of Orissa.

This matter is pending before the Hon'ble Supreme long with SLP 7165/2005.

The Hon'ble Supreme Court passed an order dated August 1, 2005 directing the SLP to be tagged along with SLP No. 7165/2005.

The Supreme Court has passed an order on October 24, 2005 listing the matter on January 10, 2006 before the appropriate bench for appointing a date of hearing.

**Litigation against our Promoters**

- |    |   |     |
|----|---|-----|
| a) | Bank Guarantees given by                                    | NIL |
| b) | Claims against promoter companies not acknowledged as debts | NIL |
| c) | In respect of various labour cases pending                  | NIL |

## GOVERNMENT APPROVALS

In view of the approvals listed below, we can undertake this Issue and our current and proposed business activities and no further major approvals from any government authority/RBI are required to undertake the Issue or continue our present/proposed business activities.

### A. Approvals for the Issue

We have received the following approvals relating to the Issue:

The Board of Directors have, pursuant to resolution passed at its meeting held on June 19, 2005, authorised the Issue subject to the approval by the shareholders of our Company under Section 81(1A) of the Companies Act, and such other authorities as may be necessary.

The shareholders have, pursuant to a resolution dated July 22, 2005 under Section 81(1A) of the Companies Act, authorised the Issue in accordance with law. The Board of Directors have, pursuant to a resolution dated 19 December, 2005 authorised a committee of its Directors, referred to as the IPO Committee, to take decisions relating to the Issue on behalf of the Board of Directors.

### B. Approvals for our business

We have received the following major government and other approvals pertaining to our business:

#### Approvals/ Licences for our Company's plants and premises

*Premises at Chandrihariharpur, P.O. Kuarmunda, District Sundergarh, Orissa and office at H-3, Civil Township, Rourkela-769004*

#### 1. Approvals/ Licenses obtained

#### **Industrial Laws:**

Sl. No.	Subject matter	Description	Reference/ Licence / Registration No.	Issue Renewed Date	Expiry Date
1.	Factory	Certificate of Registration of Factory under the Factories Act, 1948 granted by the Chief Inspector of Factories, Orissa.	Registration Number: SG-492	October 28, 2003	N.A.
2.	Factory	Registration and licence to work a factory under the Factories Act, 1948 granted by the Director of Factories & Boilers, Orissa.	Registration Number: SG-492 Serial No. 04462	January 1, 2006	December 31, 2006

Sl. No.	Subject matter	Description	Reference/ Licence / Registration No.	Issue Renewed Date	Expiry Date
3.	IEM	Industrial Entrepreneur Memorandum Acknowledgement issued subject to the provisions of Press Note No. 6 dated 29 <sup>th</sup> July 1993 & Press Note No. 17 dated 28 <sup>th</sup> November 1997 regarding filing of IEM, by the Secretariat of Industrial Assistance, Department of Industrial Policy & Promotion, Ministry of Industry, Government of India for manufacture of sponge iron proposed capacity 108000 METRIC TONNE and steel ignot proposed capacity 50000 MT, NIC Codes No. 3303 and 3302 respectively.	IEM Acknowledgement No. 1433/SIA/IMO/2002	June 14, 2002	NA
4.		Industrial Entrepreneur Memorandum Acknowledgement issued subject to the provisions of Press Note No. 6 dated 29 <sup>th</sup> July 1993 & Press Note No. 17 dated 28 <sup>th</sup> November 1997 regarding filing of IEM, by the Secretariat of Industrial Assistance, Department of Industrial Policy & Promotion, Ministry of Industry, Government of India for manufacture of sponge iron proposed capacity 242000 and steel billets and bar wire rod proposed capacity 100000, NIC Codes No. 3303 and 3302 respectively.	IEM Acknowledgement No. 135/SIA/IMO/2003	January 14, 2003	NA

Sl. No.	Subject matter	Description	Reference/ Licence / Registration No.	Issue Renewed Date	/ Expiry Date
5.		Industrial Entrepreneur Memorandum Acknowledgement issued subject to the provisions of Press Note No. 6 dated 29 <sup>th</sup> July 1993 & Press Note No. 17 dated 28 <sup>th</sup> November 1997 regarding filing of IEM, by the Secretariat of Industrial Assistance, Department of Industrial Policy & Promotion, Ministry of Industry, Government of India for manufacture of power and thermal coal, proposed capacity 20.00 mega watt NIC Code No. 4022	IEM Acknowledgement No. 154/SIA/IMO/2003	January 16, 2003	NA
6.		Industrial Entrepreneur Memorandum Acknowledgement issued subject to the provisions of Press Note No. 6 dated 29 <sup>th</sup> July 1993 & Press Note No. 17 dated 28 <sup>th</sup> November 1997 regarding filing of IEM, by the Secretariat of Industrial Assistance, Department of Industrial Policy & Promotion, Ministry of Industry, Government of India for manufacture of pig iron/hot metal proposed capacity 500000 METRIC TONNE NIC Code No. 3304	IEM Acknowledgement No. 2336/SIA/IMO/2003	August 25, 2003	NA

<b>Sl. No.</b>	<b>Subject matter</b>	<b>Description</b>	<b>Reference/ Licence / Registration No.</b>	<b>Issue Renewed Date</b>	<b>Expiry Date</b>
7.		Industrial Entrepreneur Memorandum Acknowledgement issued subject to the provisions of Press Note No. 6 dated 29 <sup>th</sup> July 1993 & Press Note No. 17 dated 28 <sup>th</sup> November 1997 regarding filing of IEM, by the Secretariat of Industrial Assistance, Department of Industrial Policy & Promotion, Ministry of Industry, Government of India for manufacture of coke oven products proposed capacity 400000 METRIC TONNE NIC Code No. 3180	IEM Acknowledgement No. 1865/SIA/IMO/2004	May 27, 2004	NA
8.	IEM	Industrial Entrepreneur Memorandum Acknowledgement issued subject to the provisions of Press Note No. 6 dated 29 <sup>th</sup> July 1993 & Press Note No. 17 dated 28 <sup>th</sup> November 1997 regarding filing of IEM, by the Secretariat of Industrial Assistance, Department of Industrial Policy & Promotion, Ministry of Industry, Government of India for manufacture of generation and transmission of electric energy produced in coal based thermal power plants proposed capacity 5.00 mega watt NIC Code No. 4002	IEM Acknowledgement No. 1866/SIA/IMO/2004	May 27, 2004	NA

Sl. No.	Subject matter	Description	Reference/ Licence / Registration No.	Issue Renewed Date	Expiry Date
9.		Industrial Entrepreneur Memorandum Acknowledgement issued subject to the provisions of Press Note No. 6 dated 29 <sup>th</sup> July 1993 & Press Note No. 17 dated 28 <sup>th</sup> November 1997 regarding filing of IEM, by the Secretariat of Industrial Assistance, Department of Industrial Policy & Promotion, Ministry of Industry, Government of India for manufacture of generation and transmission of electric energy produced in gas based thermal power plants proposed capacity 15.00 mega watt NIC Code No. 4004	IEM Acknowledgement No. 1881/SIA/IMO/2004	May 28, 2004	NA
10.		Industrial Entrepreneur Memorandum Acknowledgement issued subject to the provisions of Press Note No. 6 dated 29 <sup>th</sup> July 1993 & Press Note No. 17 dated 28 <sup>th</sup> November 1997 regarding filing of IEM, by the Secretariat of Industrial Assistance, Department of Industrial Policy & Promotion, Ministry of Industry, Government of India for manufacture of pig iron / hot metal proposed capacity 160000 MT NIC Code No. 3304	IEM Acknowledgement No. 4975/SIA/IMO/2004	December 27, 2004	NA

Sl. No.	Subject matter	Description	Reference/ Licence / Registration No.	Issue Renewed Date	Expiry Date
11.		Industrial Entrepreneur Memorandum Acknowledgement issued subject to the provisions of Press Note No. 6 dated 29 <sup>th</sup> July 1993 & Press Note No. 17 dated 28 <sup>th</sup> November 1997 regarding filing of IEM, by the Secretariat of Industrial Assistance, Department of Industrial Policy & Promotion, Ministry of Industry, Government of India for manufacture of sponge iron proposed capacity 1350000 MT NIC Code No. 3303	IEM Acknowledgement No. 4974/SIA/IMO/2004	December 27, 2004	NA
12.	Boiler	Provisional order in form V under section 9 of the Indian Boilers Act, 1923 granting permission to use the horizontal multitubular shel type boiler ata maximum pressure of 17.5 kg per sq mtr.	12/05	August 23, 2005	6 months after which boiler certificate is to be issued.
13.	Contract labour	Certificate of registration in form II under section 7(2) of the Contract Labour (Regulation and Abolition) Act, 1970 granted by the district Labour Officer cum Registering Officer, Government of Orissa.	No. 230	May 17, 2003	
14.	EPF	Letter issued by the Assistant Provident Fund Commissioner, Employees' Provident Fund Organization, Orissa, Rourkela stating that the Employees' Provident Funds & Miscellaneous Provision Act, 1952 and Scheme framed thereunder is applicable to our Company, thereby	No. OR/RL/7996	January 1, 2004	

Sl. No.	Subject matter	Description	Reference/ Licence / Registration No.	Issue Renewed Date	Expiry Date
		allotting a number.			
15.	Standing order	Letter no. 640092)/DLC issued by the Deputy Labour Commissioner & Certifying Officer under I.E. (S.O.) Act enclosing a certified copy of the Standing Orders of the Company.		October 20, 2004	NA

**Environmental Laws:**

Sl. No.	Subject matter	Description	Reference/ Licence / Registration No.	Issue Renewed Date	Expiry Date
1.	Consent order under Air.	Renewal consent order under section 21 of the Air (Prevention & Control of Pollution) Act, 1981, issued by the Environmental Engineer-I, State Pollution control Board, Orissa.	Renewal Consent Order No. APC 1599 issued vide letter no. 29147	September 22, 2005	Valid up to March 31, 2006 for Kiln-I,II,III*
2.	Consent order under Water	Renewal consent order under section 25 of the Water (Prevention & Control of Pollution) Act, 1974 issued by Environmental Engineer-I, State Pollution control Board, Orissa.	Renewal Consent Order No. WPC / 1559 issued vide letter no. 29149	September 22, 2005	Valid up to March 31, 2006 for Kiln-I,II,III (3*100 TPD)*
3.	Consent for operation of blast furnace	Consent for operation of Kiln-V (100TPD) under section 21 of the Air (Prevention & Control of Pollution) Act, 1981, issued by the Member Secretary, State Pollution Control Board, Orissa.	Consent Order No. 34149SPCB/BBSR-I-IND(CON)-5060	November 11, 2005	Valid up to March 31, 2006
4.	Consent for discharge of sewage	Consent for discharge of sewage and/or trade effluent under section 25/26 of the Water (Prevention & Control of Pollution) Act, 1974, issued by the Member Secretary, State Pollution Control Board, Orissa.	Consent Order No. 34151SPCB/BBSR-I-IND(CON)-5060	November 11, 2005	Valid up to March 31, 2006

Sl. No.	Subject matter	Description	Reference/ Licence / Registration No.	Issue Renewed Date	Expiry Date
5.	Ministry of Forest	Permission from the Ministry of Environment and Forests according environmental clearances to the integrated steel complex at Village Chadri Hariharpur, under the provisions of EIA Notification dated January 27, 1994.	No. J-110111/61/2005-IA II (I)	June 21, 2005	
6.	PCB consent to establish	Office memorandum issued by the State Pollution Control Board, Orissa conveying consent to establish for establishment of the integrated steel plant under section 25 of Water (Prevention & Control of Pollution) Act, 1974 and section 21 of Air (Prevention & Control of Pollution) Act, 1981 for the manufacture and production of DRI, steel billets through MBF, steel billet through DRI-EAF and power plant	No. 12665	April 8, 2005	April 8, 2010

\* With respect to kiln IV, our Company has written a letter dated January 3, 2006 to the State Pollution Control Board, Orissa (for the purpose of this paragraph referred to as “Board”) intimating them that vide letter dated September 22, 2005 the Board had renewed consent for kiln nos I, II & III and not for kiln IV. However, since consent for kiln IV had been granted earlier and the application for renewal contained a renewal for kiln IV, as per the provisions of the section 25(7) of Water (Prevention & Control of Pollution) Act, 1974 and section 21(4) of Air (Prevention & Control of Pollution) Act, 1981, on the expiry of four months from the date of application, unless consent given or refused earlier shall be deemed to have been unconditionally granted.

#### Other Laws:

Sl. No.	Subject matter	Description	Reference/ Licence / Registration No.	Issue Renewed Date	Expiry Date
1	ROC	Company Registration Number	21-93945	November 21, 2001	Valid until cancelled
2	PAN	Permanent Account Number	PAN NO. AABCN5676P		Valid until cancelled
3	TAN	Tax Deduction Account	BBNN00021A		Valid until

Sl. No.	Subject matter	Description	Reference/ Licence / Registration No.	Issue Renewed Date	Expiry Date
		number			cancelled
4	VAT/TIN <sup>1</sup>	Tax payers Identification Number issued by the Office of the Commercial Tax Officer, Rourkela II Circle under the seal of the Sales Tax Officer.	TIN No. 21472000074	April 1, 2005	
5.	Central Sales Tax	Certificate of registration in form B under rule 5 of the Central Sales Tax (Registration and Turnover) Rules, 1957 issued by the assistant commissioner.	No. 19461045205	August 5, 2005	Valid until cancelled
6.	Central Excise	Registration under the Central Excise Rules 2001, issued by the Superintendent, Central Excise and Customs, Rourkela City Range.	Registration no. AABCN5676P/XM/001	2002	Valid till the registrant carries on the activity for which the registration is granted or surrenders it or till revoked or suspended.
6.	Orissa Sales Tax	Certificate of registration under the Orissa Sales Tax Rules, 1947 issued by the Sales Tax Officer	RL -II-2376	Registered on August 2, 2002.  Renewed on March 22, 2005	Valid for the period 2005-06
7.	Panchayat NOC	Certificate of no objection granted by the Panchayat, Khukhundertahal G.P. for setting up of sponge iron plants, coal beneficiation plants, mini blast furnaces, steel melting shops, ferro alloy plants, power plants and allied plants at Chadrihariharpur, Kuarmunda Block,		September 12 2003	

i. <sup>1</sup> Form VAT-108 being application for amendment of registration certificate dated September 19, 2005 for change of name to Adhunik Metaliks Ltd.

Sl. No.	Subject matter	Description	Reference/ Licence / Registration No.	Issue Renewed Date	Expiry Date
		Sundergarh District on plot no. 96,98,69/176, 99/177, 101, 102, 103, 104, 105, 106, 107, 109, 120, 121, 122, 123, 124 of khata no. 23 & 24 and other required land and drawal of water.			
8.	Orissa Minerals (Prevention of theft, smuggling & other unlawful Activities) Act, 1989	Licence under Orissa Minerals (Prevention of theft, smuggling & other unlawful Activities) Act, 1989 issued by the Deputy Director, Mines, Rourkela for procuring/ storing/processing of coal, iron ore, quartz, dolomite.	Office proceedings no. 9984/Mines, Dt 8/4/05	April 22, 2005	Valid for one year from date of issue.
9.		Licence under Orissa Minerals (Prevention of theft, smuggling & other unlawful Activities) Act, 1989 issued by the Deputy Director, Mines, Rourkela for procuring/ storing/processing of coal, dolomite.	Office proceedings no. 9984/Mines, Dt 8/04/05	w.e.f. April 4, 2005	Valid for one year from date of issue.
10.		Licence under Orissa Minerals (Prevention of theft, smuggling & other unlawful Activities) Act, 1989 issued by the Deputy Director, Mines, Rourkela for procuring/ storing/processing of iron ore, manganese, dolomite, limestone, quartz and coke.	Office proceedings no. 11968/Mines, Dt. 11/05/05	w.e.f. May 11, 2005	Valid for one year from date of issue.
11.		Licence under Orissa Minerals (Prevention of theft, smuggling & other unlawful Activities) Act, 1989 issued by the Deputy Director, Mines, Rourkela for procuring/ storing/processing of coal.	Office proceedings no. 14852/Mines, Dt 03/08/05	w.e.f. May 22, 2005	Valid for one year from date of issue.

Sl. No.	Subject matter	Description	Reference/ Licence / Registration No.	Issue Renewed Date	Expiry Date
12.		Licence under Orissa Minerals (Prevention of theft, smuggling & other unlawful Activities) Act, 1989 issued by the Deputy Director, Mines, Rourkela for coal and dolomite.	Office proceedings no. 11032/Mines, Dt 29/04/05	w.e.f. May 1, 2005	Valid for one year from date of issue.
13.		Licence under Orissa Minerals (Prevention of theft, smuggling & other unlawful Activities) Act, 1989 issued by the Deputy Director, Mines, Rourkela for procuring/ processing of coal, dolomite, limestone, quartz.	Office proceedings no. 14469/Mines, Dt 21/07/05	w.e.f July 21, 2005	Valid for one year from date of issue.
14.	Railway clearance	Rail transport clearance issued by the Ministry of Railways, Government of India for outward and inward traffic of coal – 1.8 LT/annum, iron ore – 1.8 LT/annum, sponge iron 1.8 LT/annum for the sponge iron plant near Kuarmunda on Roukela-Birmitrapur section of S.E. Railways.		August 11, 2004	N.A.
15.	National highway authorities clearance	Permission from the Office of Chief Engineer, National Highways, Orissa to lay water supply pipeline from Sankha river to the factory.		August 24, 2003	N.A.
16.	Dept of water resources	Permissions from the Department of Water Resources, Government of Orissa to draw required quantity of water during first phase 300 M3/hr and during second phase 80 M3/hr from river Koel for the integrated steel plant at Kuamunda		August 10, 2004	
17	Orissa Act	Application for	PR-RL-1066	March 22,	

Sl. No.	Subject matter	Description	Reference/ Licence / Registration No.	Issue Renewed Date	Expiry Date
	on Professions Trade, Calling & employment Act, 2000	enrolment/amendment-cum-enrolment certificate stamped by the assessing authority, Profession Tax Officer		2005	
18	Inspection Report	Inspection report in form III under rule 46 of I.E. Rules, 1956 of the initial inspection for the purpose of energizing the 33/0.43 K.V., 2000 KVA Transformer installed.	Report No. 95 of 2005 –2006	Date of inspection: June 14, 2005	
19	Energy meters test certificate	Test certificate for energy meters issued by the Standard Testing Laboratory, Government of Orissa	Test Report No. STD/2004/720/(2)	February 7, 2004	
20.	Inspection report – Electrical Inspector	Initial inspection report of the electrical installation of 132/33 KV S/S & 33/11 KV S/S issued by the Office of the Chief Electrical Inspector (T&D), Government of Orissa, permitting the electrical installations to be energized.	Report No. 7 of 2005-06	July 29, 2005	Valid for a period of one year.
21.		Initial inspection report of the electrical installation of 132 KV bay extension at 132/33 KV Grid sub-station Chhend and 132 KV S.C. line Chhend to 132/33 KV sub-station issued by the Office of the Chief Electrical Inspector (T&D), Government of Orissa, permitting the electrical installations to be energized.	Report No. 8 of 2005-06	July 29, 2005	Valid for a period of one year
22.	OPTCL certificate	Certificate issued by the Sub-Divisional Officer, EHT (Const.) Sub-Division, Orissa Power Transmission Corporation Limited		August 6, 2005	

Sl. No.	Subject matter	Description	Reference/ Licence / Registration No.	Issue Renewed Date /	Expiry Date
		certifying that the 132 KV single circuit line from Chhend Grid Sub-Station to the Company has no standing tree under the line and men and materials are free from line, hence the 132 KV line may be charged.			
23.	Permission for conversion of use of land.	Standard form of lease deeds for lease of agricultural land for non-agricultural purpose in Form 27, issued under rule 12-A (5) of the Orissa Land Reforms Manual, for land at Sundergarh.		Date of lease deed: August 31, 2002	In perpetuity

## 1.2 Applications for approvals and licences

- Application in form IV for consent for beginning to make any new discharge/continuing discharge of sewage / trade effluent under section 25 or 26 of the Water (Prevention and Control) of Pollution Act, 1974.

## 1.3 Application for mining lease for iron ore to the government of Orissa for 220.20 hectares of land located in village Khajuridihi R.F. under Bonai sub-division of Sundergarh district.

Our Company had made an application under the Mining Concession Rules, 1960 to the government of Orissa for grant of a mining lease for iron ore. Pursuant to the said application our Company has received an acknowledgment from the government of Orissa dated January 6, 2005 in form D under rule 10(4) of the Mining Concession Rules, 1960 for receipt of the application made by our Company for the mining lease.

Subsequently, M/s. Industrial Promotion and Investment Corporation of Orissa Limited (IPICOL), a government of Orissa undertaking, issued a letter dated June 25, 2005 to the principal secretary to the government, department of steel & mines, government of Orissa, request the government of Orissa to consider recommending the mining lease.

## 1.4 Application for mining lease for iron ore to the government of Orissa for 109.79 hectares of land located in village Deghar, Kulnur Mahadernasa sub-division of Keonjar district.

Erstwhile Neepaz Metaliks Pvt. Ltd. had made an application under the Mining Concession Rules, 1960 to the Principal Secretary to the Government of Orissa, Department of Steel and Mines, through the collector, Keonjar for grant of a mining lease for iron ore for captive use.

Pursuant to the said application an acknowledgment from the government of Orissa dated May 5, 2003 in form D under rule 10(4) of the Mining Concession Rules, 1960 for receipt of the application made for the mining lease was received.

### 1.5 Application for change of name of our Company from Neepaz Metaliks to Adhunik Metaliks:

a) Vide letter dated August 16, 2005 our Company sent an intimation to the following government department / authorities informing on the name change:

- i) Collector & Dist Magistrate, Sundargarh;
- ii) Superintendent of Police, Sundergarh;

b) Vide letter dated September 23, 2005 addressed to the Assistant P.F. Commissioner, Rourkela, our Company submitted the monthly return for the month of August as also intimating on the change of name to Adhunik Metaliks Limited.

c) Vide letter dated November 7, 2005 addressed to the assistant commissioner, sales tax, Kolkata, our Company requested for amendment in the registration certificate with an incorporation of the same in our branch office at Durgapur, in respect of VAT R.C. No. 19461045011 / CST No. 19461045205, in view of the change in the name of our Company

### 1.5 Hazardous Waste (Management & Handling) Rules, 1989

Letter dated December 8, 2004 issued by the State Pollution Control Board, Orissa to our Company for applying for authorisation under Hazardous Waste (Management & Handling) Rule, 1989, referring to letter no. 18653 dated June 7, 2004 issued by the State Pollution Control Board. In reply to the said letter, our Company issued a letter dated December 18, 2004 stating that the letter no. 18653 dated June 7, 2004 issued by the State Pollution Control Board has not been received by our Company and further that no waste is produced in DRI operations. The only form of waste is a negligible quantity of waste oil is collected during general annual maintenance, which is used for lubrication of machinery parts and burnt in the rotary kilns.

## 2. Premises at 14 N.S. Road, Kolkata, West Bengal

### 2.1 Approvals/ Licences obtained

Sl. No.	Description	Reference/ Licence No.	Issue Date	Expiry Date
1.	Enrolment under the West Bengal State Tax on Professions, Trades, Callings and Employments Act, 1979.	No. ECC0094986	June 14, 2005	N.A.
2.	Certificate of registration in form 3 issued by the assistane commissioner sales tax under rule 3 of the West Bengal Value Added Tax Rules, 2005	Certificate of Registration no. 19461045011	August 5, 2005 valid w.e.f. July 9, 2005	
3.	Certificate of Importer-Exporter Code (IEC) issued by the foreign trade development officer, Zonal Jt. Director General of Foreign Trade, Ministry of Commerce	IEC Number 0203024877*	February 13, 2004	Valid till change of name or constitution of IEC holder, unless the consequential changes are effected by the licensing authority, the same shall

<b>Sl. No.</b>	<b>Description</b>	<b>Reference/ Licence No.</b>	<b>Issue Date</b>	<b>Expiry Date</b>
				continue to be valid.

\*Applicable to branches situated at

- Chadrihariharpur Kuarmunda Sundargarh, Orissa,
- 2/1A, Sarat Bose Road, Landsdowne Towers, Kolkata,
- 2, Inner Circle Road, Shanti Hari Tower, Bistupur, Jamshedpur,
- H-3, Civil Township, Rourkela, Orissa.

## OTHER REGULATORY AND STATUTORY DISCLOSURES

### Authority for the Issue and details of resolutions passed for the Issue

The shareholders have, pursuant to a resolution dated July 22, 2005 under Section 81(1A) of the Companies Act, authorised the Issue in accordance with law. The Board of Directors have, pursuant to a resolution dated 19 December, 2005 authorised a committee of its Directors, referred to as the IPO Committee, to take decisions relating to the Issue on behalf of the Board of Directors.

### Prohibition by SEBI

Our Company, our Directors, our Promoters, Directors/persons in control of promoter companies, our Group Companies, Directors/Persons in control of our Group Companies and affiliates and companies with which our Directors are associated with as directors, have not been prohibited from accessing or operating in capital markets under any order or direction passed by SEBI.

Our Company, promoters, their relatives (as per Companies Act, 1956), group companies, associate companies have not been detained as willful defaulters by RBI/government authorities and there have been no violations of the securities law committed by them or pending against them.

### Eligibility of the Issuer

We are an unlisted company not complying with the conditions specified in Clause 2.2.1 of the SEBI Guidelines and are, therefore, required to meet both the conditions detailed in Sub-Clauses (a) and (b) of Clause 2.2.2 of the SEBI Guidelines.

- We are complying with Clause 2.2.2(a)(i) of the SEBI Guidelines and at least 50% of the Issue is proposed to be Allotted to QIB Bidders and in the event we fail to do so, the full subscription monies shall be refunded to the Bidders. Accordingly, as per the first proviso to Clause 11.3.5(i) of the SEBI Guidelines, Non-Institutional Bidders and Retail Individual Bidders will be allocated up to 15% and 35% of the Issue, respectively.
- We are also complying with Clause 2.2.2(b)(i) of the SEBI Guidelines and the post-Issue face value capital of the Company shall be Rs. 912.31 million, which is more than the minimum requirement of Rs. 10 crore (Rs. 100 million).

Hence, we are eligible for the Issue under Clause 2.2.2 of the SEBI Guidelines.

Further, in accordance with Clause 2.2.2A of the SEBI Guidelines, we undertake that the number of allottees, i.e., Persons receiving Allotment in the Issue shall be at least 1,000, otherwise, the entire application money will be refunded forthwith. In case of delay, if any, in refund, our Company shall pay interest on the application money at the rate of 15% per annum for the period of delay.

### Disclaimer Clause

**AS REQUIRED, A COPY OF THE PROSPECTUS HAS BEEN SUBMITTED TO SEBI. IT IS TO BE DISTINCTLY UNDERSTOOD THAT SUBMISSION OF THE PROSPECTUS TO SEBI SHOULD NOT, IN ANY WAY, BE DEEMED OR CONSTRUED THAT THE SAME HAS BEEN CLEARED OR APPROVED BY SEBI. SEBI DOES NOT TAKE ANY RESPONSIBILITY EITHER FOR THE FINANCIAL SOUNDNESS OF ANY SCHEME OR THE PROJECT FOR WHICH THE ISSUE IS PROPOSED TO BE MADE OR FOR THE CORRECTNESS OF THE STATEMENTS MADE OR OPINIONS EXPRESSED IN THE PROSPECTUS. THE BOOK RUNNING LEAD MANAGER, SBI CAPITAL MARKETS LIMITED HAS CERTIFIED THAT THE DISCLOSURES MADE IN THE PROSPECTUS ARE GENERALLY ADEQUATE AND ARE IN CONFORMITY**

**WITH SEBI (DISCLOSURES AND INVESTOR PROTECTION) GUIDELINES, 2000 AS FOR THE TIME BEING IN FORCE. THIS REQUIREMENT IS TO FACILITATE INVESTORS TO TAKE AN INFORMED DECISION FOR MAKING AN INVESTMENT IN THE PROPOSED ISSUE.**

**IT SHOULD ALSO BE CLEARLY UNDERSTOOD THAT WHILE THE COMPANY IS PRIMARILY RESPONSIBLE FOR THE CORRECTNESS, ADEQUACY AND DISCLOSURE OF ALL RELEVANT INFORMATION IN THE PROSPECTUS, THE BOOK RUNNING LEAD MANAGER IS EXPECTED TO EXERCISE DUE DILIGENCE TO ENSURE THAT THE COMPANY DISCHARGES ITS RESPONSIBILITY ADEQUATELY IN THIS BEHALF AND TOWARDS THIS PURPOSE, THE BOOK RUNNING LEAD MANAGERS, SBI CAPITAL MARKETS LIMITED AND KARVY INVESTOR SERVICES LIMITED HAVE FURNISHED TO SEBI, A DUE DILIGENCE CERTIFICATE DATED JANUARY 09, 2006 IN ACCORDANCE WITH THE SEBI (MERCHANT BANKERS) REGULATIONS, 1992 WHICH READS AS FOLLOWS:**

- “(I) WE HAVE EXAMINED VARIOUS DOCUMENTS INCLUDING THOSE RELATING TO LITIGATION LIKE COMMERCIAL DISPUTES, PATENT DISPUTES, DISPUTES WITH COLLABORATORS ETC. AND OTHER MATERIALS IN CONNECTION WITH THE FINALISATION OF THE PROSPECTUS PERTAINING TO THE SAID ISSUE;**
- (II) ON THE BASIS OF SUCH EXAMINATION AND THE DISCUSSIONS WITH THE COMPANY, ITS DIRECTORS AND OTHER OFFICERS, OTHER AGENCIES, INDEPENDENT VERIFICATION OF THE STATEMENTS CONCERNING THE OBJECTS OF THE ISSUE, PROJECTED PROFITABILITY, PRICE JUSTIFICATION AND THE CONTENTS OF THE DOCUMENTS MENTIONED IN THE ANNEXURE AND OTHER PAPERS FURNISHED BY THE COMPANY.**

**WE CONFIRM THAT:**

- (A) THE PROSPECTUS FORWARDED TO SEBI IS IN CONFORMITY WITH THE DOCUMENTS, MATERIALS AND PAPERS RELEVANT TO THE ISSUE;**
- (B) ALL THE LEGAL REQUIREMENTS CONNECTED WITH THE SAID ISSUE AS ALSO THE GUIDELINES, INSTRUCTIONS, ETC. ISSUED BY SEBI, THE GOVERNMENT AND ANY OTHER COMPETENT AUTHORITY IN THIS BEHALF HAVE BEEN DULY COMPLIED WITH; AND**
- (C) THE DISCLOSURES MADE IN THE PROSPECTUS ARE TRUE, FAIR AND ADEQUATE TO ENABLE THE INVESTORS TO MAKE A WELL-INFORMED DECISION AS TO THE INVESTMENT IN THE PROPOSED ISSUE.**
- (D) BESIDES OURSELVES, ALL THE INTERMEDIARIES NAMED IN THE PROSPECTUS ARE REGISTERED WITH SEBI AND THAT TILL DATE SUCH REGISTRATIONS ARE VALID.**
- (E) WHEN UNDERWRITTEN, WE SHALL SATISFY OURSELVES ABOUT THE WORTH OF THE UNDERWRITERS TO FULFIL THEIR UNDERWRITING COMMITMENTS.”**
- (F) WE CERTIFY THAT WRITTEN CONSENT FROM THE PROMOTERS HAS BEEN OBTAINED FOR INCLUSION OF THEIR SECURITIES AS PART OF PROMOTER’S CONTRIBUTION SUBJECT TO LOCK-IN AND THE SECURITIES PROPOSED TO FORM PART OF THE PROMOTER’S CONTRIBUTION SUBJECT TO LOCK-IN, WILL NOT BE DISPOSED/SOLD/TRANSFERRED BY THE PROMOTERS DURING THE**

**PERIOD STARTING FROM THE DATE OF FILING THE PROSPECTUS WITH THE SEBI TILL THE DATE OF COMMENCEMENT OF LOCK-IN PERIOD AS STATED IN THE PROSPECTUS.**

**ALL LEGAL REQUIREMENTS PERTAINING TO THE ISSUE WILL BE COMPLIED WITH AT THE TIME OF FILING OF THE PROSPECTUS WITH THE ROC IN TERMS OF SECTION 60B OF THE COMPANIES ACT.**

**ALL LEGAL REQUIREMENTS PERTAINING TO THE ISSUE WILL BE COMPLIED WITH AT THE TIME OF REGISTRATION OF THE PROSPECTUS WITH THE ROC IN TERMS OF SECTION 56, SECTION 60 AND SECTION 60B OF THE COMPANIES ACT.**

**THE FILING OF THE PROSPECTUS DOES NOT, HOWEVER, ABSOLVE THE COMPANY FROM ANY LIABILITIES UNDER SECTION 63 AND SECTION 68 OF THE COMPANIES ACT OR FROM THE REQUIREMENTS OF OBTAINING SUCH STATUTORY AND OTHER CLEARANCES AS MAY BE REQUIRED FOR THE PURPOSE OF THE PROPOSED ISSUE. SEBI FURTHER RESERVES THE RIGHT TO TAKE UP AT ANY POINT OF TIME, WITH THE BOOK RUNNING LEAD MANAGERS, ANY IRREGULARITIES OR LAPSES IN THE PROSPECTUS.**

#### **Disclaimer from our Company and the BRLMs**

Our Company, our Directors and the BRLMs accept no responsibility for statements made otherwise than in this Prospectus or in the advertisements or any other material issued by or at instance of the above mentioned entities and anyone placing reliance on any other source of information, including our website, www.adhunikgroup.com, would be doing so at his or her own risk.

**The BRLMs accept no responsibility, save to the limited extent as provided in the memorandum of understanding entered into among the BRLMs and our Company dated 9, January 2006 and the Underwriting Agreement to be entered into among the Underwriters and our Company.**

All information shall be made available by our and BRLMs to the public and investors at large and no selective or additional information would be available for a section of the investors in any manner whatsoever including at road show presentations, in research or sales reports or at bidding centres etc.

#### **Disclaimer in respect of jurisdiction**

This Issue is being made in India to persons resident in India (including Indian nationals resident in India who are majors, HUFs, companies, corporate bodies and societies registered under the applicable laws in India and authorised to invest in shares, Indian Mutual Funds registered with SEBI, Indian financial institutions, commercial banks, regional rural banks, co-operative banks (subject to RBI permission), or trusts under the applicable trust law and who are authorised under their constitution to hold and invest in shares, permitted insurance companies and pension funds). This Prospectus does not, however, constitute an invitation to subscribe to Equity Shares offered hereby in any other jurisdiction to any person to whom it is unlawful to make an offer or invitation in such jurisdiction. Any person into whose possession this Prospectus comes is required to inform himself or herself about and to observe, any such restrictions. Any dispute arising out of this Issue will be subject to the jurisdiction of appropriate court(s) in Kolkata, West Bengal only.

No action has been or will be taken to permit a public offering in any jurisdiction where action would be required for that purpose, except that this Prospectus has been filed with SEBI for observations. Accordingly, the Equity Shares, represented thereby may not be offered or sold, directly or indirectly, and this Prospectus may not be distributed, in any jurisdiction, except in accordance with the legal requirements applicable in such jurisdiction. Neither the delivery of this Prospectus nor any sale hereunder shall, under

any circumstances, create any implication that there has been no change in our affairs from the date hereof or that the information contained herein is correct as of any time subsequent to this date.

#### **DISCLAIMER STATEMENT OF STOCK EXCHANGES:**

##### **Disclaimer Clause of the BSE**

As required, a copy of this Prospectus has been submitted to BSE. BSE has given vide its letter dated February 07, 2006 permission to the Company to use the BSE's name in this Prospectus as one of the stock exchanges on which our further securities are proposed to be listed. The BSE has scrutinized this Prospectus for its limited internal purpose of deciding on the matter of granting the aforesaid permission to us.

BSE does not in any manner:

- i. warrant, certify or endorse the correctness or completeness of any of the contents of this Prospectus; or
- ii. warrant that this Company's securities will be listed or will continue to be listed on BSE; or
- iii. take any responsibility for the financial or other soundness of this Company, its promoters, its management or any scheme or project of this Company;**

And it should not for any reason be deemed or construed to mean that this Prospectus has been cleared or approved by BSE. Every person who desires to apply for or otherwise acquires any securities of this Company may do so pursuant to independent inquiry, investigation and analysis and shall not have any claim against BSE whatsoever by reason of any loss which may be suffered by such person consequent to or in connection with such subscription/acquisition whether by reason of anything stated or omitted to be stated herein or for any other reason whatsoever.

##### **Disclaimer Clause of the NSE**

As required, a copy of this Prospectus has been submitted to NSE. NSE has given vide its letter dated February 10, 2006, permission to us to use the NSE's name in this Prospectus as one of the stock exchanges on which our securities are proposed to be listed subject to the Company fulfilling the various criteria for listing including the one related to paid up capital and market capitalization (i.e., the paid up capital shall not be less than Rs 10 Crores and the market capitalization shall not be less than Rs 25 Crores at the time of listing). The NSE has scrutinized this Prospectus for its limited internal purpose of deciding on the matter of granting the aforesaid permission to us. It is to be distinctly understood that the aforesaid permission given by NSE should not in any way be deemed or construed to mean that the Prospectus has been cleared or approved by NSE; nor does it in any manner warrant, certify or endorse the correctness or completeness of any of the contents of this Prospectus; nor does it warrant that our securities will be listed or will continue to be listed on the NSE; nor does it take any responsibility for the financial or other soundness of the Company, its promoters, its management or any scheme or project of the Company.

Every person who desires to apply for or otherwise acquire any of our securities may do so pursuant to an independent inquiry, investigation and analysis and shall not have any claim against the NSE whatsoever by reason of any loss which may be suffered by such person consequent to or in connection with such subscription/acquisition whether by reason of anything stated or omitted to be stated herein or any other reason whatsoever.

#### **UNDERTAKING FROM PROMOTERS AND DIRECTORS**

*The Company accepts full responsibility for the accuracy of the information given in the prospectus and confirms that to the best of their knowledge and belief, there are no other facts, their omission of which make any statement in the Prospectus misleading and they further confirm that they have made all reasonable enquiries to ascertain such facts. Our Company further declares that the stock exchanges to which an application for official quotations are proposed to be made does not take any responsibility for the financial soundness of this offer or for the price at which the equity shares are offered or for the correctness of the statement made or opinions expressed in this prospectus. The promoters/directors declare and confirm that no information/material likely to have a bearing on the decision of investors in respect of the shares offered in terms of this prospectus has been suppressed, withheld and/or incorporated in the manner that would amount misstatement/misrepresentation, and in the event of its transpiring at any point of time till allotment/refund, as the case may be, that any information/material has been suppressed/with held and/or amounts to a misstatement/misrepresentation, the promoter/directors undertake to refund the entire application monies to all the subscribers within 7 days thereafter without prejudice to the provisions of section 63 of the Companies Act.*

## **CORPORATE GOVERNANCE**

The SEBI guidelines in respect of Corporate Governance shall be applicable to our Company immediately after listing of its shares on the stock exchange. Our Company undertakes that it shall take the necessary steps to comply with all the requirements of the guidelines on corporate governance as would be applicable to it upon listing of its shares. To ensure highest standard of corporate governance the company has already appointed three independent directors namely, Mr. L.M. Chatterjee, Mr. Supriya Gupta and Mr. N.R. Hota on the Board of the Company w.e.f . 19 December, 2005.

In this regard, our Company has already set up an audit committee and other committees as per the requirements of the revised guidelines. For details of the various committee please see the section entitled 'Management' on page 109 of this Prospectus.

## **IMPERSONATION**

**Attention of applicants is specifically drawn to the provisions of sub-section (1) of Section 68A of the Companies Act, which is reproduced below:**

**“Any person who-**

- (a) Makes in a fictitious name an application to a company for acquiring, or subscribing of any shares therein, or**
- (b) Otherwise induces a company to allot, or register any transfer of shares therein to him, or any other person in a fictitious name, shall be punishable with imprisonment for a term which may extend to five years.”**

## **MINIMUM SUBSCRIPTION**

If the Company does not receive the minimum subscription of 90% of the net offer to the public including devolvement to the Underwriters within 60 days from the date of closure of the issue, the Company shall forthwith refund the entire subscription amount received. If there is delay beyond 8 days after the Company becomes liable to pay the amount, the Company shall pay interest as per Section 73 of the Companies Act, 1956.

## **FILING**

A copy of this Prospectus has been filed with SEBI at, Ground Floor, Mittal Court, “A” Wing, Nariman Point, Mumbai 400 021.

A copy of the Prospectus, along with the documents required to be filed under Section 60B of the Companies Act, will be delivered for registration to the ROC and a copy of the Prospectus required to be filed under Section 60 of the Companies Act would be delivered for registration with ROC situated at Kolkata.

## **LISTING**

Applications have been made to the NSE and BSE for permission to deal in and for an official quotation of the Equity Shares of our Company. The BSE shall be the Designated Stock Exchange with which the basis of allocation will be finalised for the Issue.

We have received in-principle approval from BSE vide their letter no List/SMG/SM/PS/2006 dated February 7, 2006 and from NSE vide their letter dated February 10, 2006.

If the permission to deal in and for an official quotation of the Equity Shares are not granted by any of the Stock Exchanges, our Company shall forthwith repay, without interest, all moneys received from the applicants in pursuance of this Prospectus. If such money is not repaid within eight days after our Company becomes liable to repay it (i.e., from the date of refusal or within 15 days from the date of Bid/Issue Closing Date, whichever is earlier), then our Company shall, on and from expiry of eight days, be liable to repay the money, with interest at the rate of 15% per annum on application money, as prescribed under Section 73 of the Companies Act.

Our Company shall ensure that all steps for the completion of the necessary formalities for listing and commencement of trading at the Stock Exchanges are taken within seven working days of finalisation of the basis of Allotment for the Issue.

## **CONSENTS**

Consents in writing of our Directors, the Company Secretary and Compliance Officer, the Auditors, the domestic legal counsels, the Bankers to the Issue, Bankers to the Company and the Book Running Lead Managers, the Syndicate Members, the Escrow Collection Bankers and the Registrar to the Issue to act in their respective capacities, have been obtained and filed along with a copy of the Prospectus with the ROC as required under Sections 60 and 60B of the Companies Act and such consents have not been withdrawn up to the time of delivery of the Prospectus for registration with the ROC.

S.R. Batliboi & Co., Chartered Accountants, our Auditors have given their written consent to the inclusion of their report in the form and context in which it appears in this Prospectus and such consent and report has not been withdrawn up to the time of delivery of this Prospectus for registration with the ROC.

## **EXPERT OPINION**

Except as stated in the sections titled “Objects of the Issue”, “Statement of Tax Benefits” and “Financial Statements” beginning on pages 28, 49, and 148 respectively, of the Prospectus, we have not obtained any expert opinions.

## **EXPENSES OF THE ISSUE**

The expenses of this Issue include, among others, underwriting and management fees, selling commission, printing and distribution expenses, legal fees, statutory advertisement expenses and listing fees. The estimated expenses of the Issue are as follows:

<b>Activity</b>	<b>Expense (Rs. in Lacs)</b>
Lead management, underwriting and selling commission	450
Advertisement and marketing expenses**	127

Printing, stationery including transportation of the same	222
Others (Registrar's fees, legal fees, listing fees, etc.)	81
<b>Total estimated Issue expenses</b>	<b>880</b>

#### **FEES PAYABLE TO THE BOOK RUNNING LEAD MANAGERS AND SYNDICATE MEMBERS**

The total fees payable by our Company to the Book Running Lead Managers (including underwriting commission and selling commission) will be as per their respective engagement letters, copies of which are available for inspection at our corporate office.

#### **FEES PAYABLE TO THE REGISTRAR TO THE ISSUE**

The fees payable by us to the Registrar to the Issue for processing of application, data entry, printing of CAN/refund order, preparation of refund data on magnetic tape, printing of bulk mailing register will be as per the memorandum of understanding signed with our Company dated November 9, 2005.

The Registrar to the Issue will be reimbursed for all out-of-pocket expenses including cost of stationery, postage, stamp duty and communication expenses. Adequate funds will be provided by us to the Registrar to the Issue to enable them to send refund orders or Allotment advice by registered post/speed post/under certificate of posting.

#### **Previous Rights and Public Issues**

We have not made any public issue or rights issue of our Equity Shares in the five years preceding the date of this Prospectus.

#### **ISSUES OTHERWISE THAN FOR CASH**

We have issued 40,00,000 equity shares of Rs. 10/- each for consideration other than cash to the shareholders of Adhunik Minerals and Alloys Ltd. Pursuant to the Scheme of Amalgamation sanctioned by the High Court of Calcutta on April 11, 2005. Further we have issued 85,45,152 equity shares as bonus in the ratio of 5:44 on October 06, 2003. Other than this we have not issued any Equity Shares for consideration otherwise than for cash.

#### **COMMISSION AND BROKERAGE PAID ON PREVIOUS EQUITY ISSUES BY US**

Since this is the initial public offer of the Company, no sum has been paid or has been payable as commission or brokerage for subscribing to or procuring or agreeing to procure subscription for any of our Equity Shares since our inception.

#### **LISTED COMPANIES UNDER THE SAME MANAGEMENT**

We do not have any other listed company under the same management within the meaning of erstwhile Section 370(1B) of the Companies Act.

#### **PROMISE V/S PERFORMANCE**

There have been no public issues in the past.

#### **OUTSTANDING DEBENTURES OR BONDS OR REDEEMABLE PREFERENCE SHARES**

There are no outstanding debentures or bonds or redeemable preference shares issued by us as of the date of this Prospectus.

#### **STOCK MARKET DATA FOR OUR EQUITY SHARES**

This being an initial public offering of our Company, the Equity Shares are not listed on any stock exchange.

#### **MECHANISM FOR REDRESSAL OF INVESTOR GRIEVANCES**

The memorandum of understanding between the Registrar to the Issue and us, will provide for retention of records with the Registrar to the Issue for a period of at least one year from the last date of dispatch of letters of Allotment, demat credit, refund orders to enable the investors to approach the Registrar to the Issue for redressal of their grievances.

All grievances relating to the Issue may be addressed to the Registrar to the Issue, giving full details such as name, address of the applicant, application number, number of shares applied for, amount paid on application, depository participant, and the bank branch or collection center where the application was submitted.

#### **DISPOSAL OF INVESTOR GRIEVANCES BY OUR COMPANY**

We estimate that the average time required by us or the Registrar to the Issue for the redressal of routine investor grievances shall be seven days from the date of receipt of the complaint. In case of non-routine complaints and complaints where external agencies are involved, we will seek to redress these complaints as expeditiously as possible.

We have appointed Mr. Sougata Sengupta, our Company Secretary as the Compliance Officer and he may be contacted in case of any pre-Issue or post-Issue related problems. He can be contacted at the following address:

Mr. Sougata Sengupta  
Landsdowne Towers  
2/1A, Sarat Bose Road  
Kolkata 700 020  
Tel: +91 33 2289 0279-84  
Fax: +91 33 2289 0285  
E-mail: ssengupta@adhunikgroup.com

#### **CHANGES IN AUDITORS**

Except as disclosed below, we have not changed our statutory auditors over the last three years.

<b>Name of Auditors</b>	<b>Date of Appointment/ Cessation</b>
ABR & Co.	September 5, 2005
S.R. Batliboi & Co.	September 5, 2005

#### **CAPITALISATION OF RESERVES OR PROFITS**

We have not capitalised our reserves or profits at any time during last five years, except for the bonus issue of Equity Shares. For details of the same, please see Note 1 of “Capital Structure - Notes to the Capital Structure” on page 13 of this Prospectus.

#### **REVALUATION OF ASSETS**

There has been no revaluation of assets by our Company during the last five years.

#### **PAYMENT OR BENEFIT TO OFFICERS OF OUR COMPANY**

Except as stated otherwise in this Prospectus, no amount or benefit has been paid or given or is intended to be paid or given to any of our officers except the normal remuneration for services rendered as Directors, officers or employees, since incorporation of our Company. None of the beneficiaries of loans and advances and sundry debtors are related to the Directors of our Company.

## ISSUE STRUCTURE

The present Issue of 27,027,027 Equity Shares at a price of Rs. 37.00 per Equity Share for cash, aggregating to Rs.10,000 lacs is being made through the 100% Book Building Process. 1,351,351 Equity Shares will be reserved in the Issue for subscription by Employees at the Issue Price. The Net Issue will comprise 25,675,676 Equity Shares of face value Rs.10 each at a price of Rs. 37.00 per Equity Share, aggregating Rs.10,000 lacs.

If at least 50% of the Net Issue cannot be allotted to QIBs, then the entire application money will be refunded forthwith

	<b>Employees</b>	<b>QIBs</b>	<b>Non-Institutional Bidders</b>	<b>Retail Individual Bidders</b>
Number of Equity Shares <sup>(1)</sup>	1,351,351 Equity Shares	At least 12,837,838 Equity Shares must be allotted to QIBs	Upto 3,851,351 Equity Shares shall be available for allocation	Upto 8,986,486 Equity Shares shall be available for allocation
Percentage of Issue size available for allocation	Up to 5% of the Issue	At least 50% of the Net Issue or the Net Issue less allocation to Non-Institutional Bidders and Retail Individual Bidders	upto 15% of Net Issue or the Net Issue less allocation to QIB Bidders and Retail Individual Bidders	Upto 35% of Net Issue or the Net Issue less allocation to QIB Bidders and Non-Institutional Bidders
Basis of Allocation if respective category is over-subscribed	Proportionate	Proportionate (a) 641,892 Equity Shares shall be available for allocation on a proportionate basis to Mutual Funds; and (b) 12,837,838 Equity Shares shall be available for allocation on a proportionate basis to all QIBs including Mutual Funds receiving allocation as per (a) above	Proportionate	Proportionate
Minimum Bid	150 Equity Shares and in multiples of 150 Equity Shares thereafter	Such number of Equity Shares that the Bid Amount exceeds Rs.100,000 and in multiples of 150 Equity Shares	Such number of Equity Shares that the Bid Amount exceeds Rs.100,000 and in multiples of 150 Equity Shares	150 Equity Shares and in multiples of 150 Equity Shares thereafter
Maximum Bid	Not exceeding the size of the Issue, subject to applicable limits	Such number of Equity Shares not exceeding the Issue, subject to applicable limits	Such number of Equity Shares not exceeding the Issue subject to applicable limits	Such number of Equity Shares whereby the Bid Amount does not exceed Rs.100,000
Mode of Allotment	Compulsorily in dematerialized form	Compulsorily in dematerialized form	Compulsorily in dematerialized form	Compulsorily in dematerialized form
Trading Lot	One Equity Share	One Equity Share	One Equity Share	One Equity Share
Who can Apply <sup>(2)</sup>	Indian Nationals who are permanent employees and Directors of the Company who are based in India. The permanent employees should be on the payroll of the Company as of February 27,2006 and the Directors should	Public financial institutions as specified in Section 4A of the Companies Act, FIIs, scheduled commercial banks, mutual funds registered with SEBI, multilateral and bilateral development financial institutions, venture capital funds registered with SEBI, state industrial development corporations, FVCIs, insurance companies registered with the Insurance Regulatory and Development	Resident Indian individuals, HUF (in the name of Karta), Eligible NRIs, companies, corporate bodies, scientific institutions societies and trusts	Individuals (including HUFs (in the name of Karta) applying for such number of Equity Shares such that the Bid Amount does not exceed Rs.100,000 and Eligible NRIs) Resident Indian individuals HUF (in the name of Karta) and Eligible NRIs

	<b>Employees</b>	<b>QIBs</b>	<b>Non-Institutional Bidders</b>	<b>Retail Individual Bidders</b>
	be Directors on the date of the Prospectus	Authority, provident funds with minimum corpus of Rs.250 million and pension funds with minimum corpus of Rs.250 million.		
Terms of Payment	Margin Amount applicable to Employees at the time of submission of Bid cum Application Form to the Syndicate	Margin Amount applicable to QIB Bidders at the time of submission of Bid cum Application Form to the members of the Syndicate	Margin Amount applicable to Non-Institutional Bidders at the time of submission of Bid cum Application Form to the members of the Syndicate	Margin Amount applicable to Retail Individual Bidders shall be payable at the time of submission of Bid cum Application Form to the members of the Syndicate
Margin Amount	Full Bid Amount on Bidding	At least 10% of the Bid Amount on bidding.	Full Bid Amount on bidding	Full Bid Amount on bidding

1. \* *Subject to valid Bids being received at or above the Issue Price, Under-subscription, if any, in any category except the QIB Portion, would be allowed to be met with spill-over from any other category or combination of categories at the discretion of our Company, in consultation with the BRLMs and the Designated Stock Exchange. However, if the aggregate demand by Mutual Funds is less than 641,892 Equity Shares (assuming QIB Portion is 50% of the Issue size, i.e.25,675,676 Equity Shares), the balance Equity Shares available for allocation in the Mutual Fund Portion will first be added to the QIB Portion and be allocated proportionately to the QIB Bidders. In the event that the aggregate demand in the QIB Portion has been met, under-subscription, if any, would be allowed to be met with spill-over from any other category or combination of categories at the discretion of our Company, in consultation with the BRLMs and the Designated Stock Exchange. However, in the event that the QIB portion remains undersubscribed the issue shall fail and full subscription monies shall be refunded.*

\*\* *In case the Bid cum Application Form is submitted in joint names, the investors should ensure that the demat account is also held in the same joint names and are in the same sequence in which they appear in the Bid cum Application Form.*

## ISSUE PROCEDURE

### Book Building Procedure

The Issue is being made through the 100% Book Building Process wherein at least 50% of the Net Issue shall be available for allocation on a proportionate basis to QIBs, including upto 5% of the QIB Portion which shall be available for allocation to Mutual Funds only. Further, upto 35% of the Net Issue shall be available for allocation on a proportionate basis to the Retail Individual Bidders and upto 15% of the Net Issue shall be available for allocation on a proportionate basis to Non-Institutional Bidders, subject to valid Bids being received at or above the Issue Price. It may be noted that the Bids received in the Employees Reservation Portion shall not be considered for the purposes of determining the Issue Price through the Book Building Process.

Bidders are required to submit their Bids through the Syndicate. Further, QIB Bids can be submitted only through Syndicate Members. Our Company, in consultation with the BRLMs, may reject any Bid procured from QIBs, for reasons to be recorded in writing provided that such rejection shall be made at the time of acceptance of the Bid and the reasons therefor shall be disclosed to the Bidders. In case of Non-Institutional Bidders and Retail Individual Bidders, our Company would have a right to reject the Bids only on technical grounds.

**Investors should note that the Equity Shares would be allotted to all successful Bidders only in the dematerialised form.**

Bidders will not have the option of getting allotment of the Equity Shares in physical form. The Equity Shares on allotment shall be traded only in the dematerialised segment of the Stock Exchanges.

### Bid cum Application Form

Bidders shall only use the specified Bid cum Application Form bearing the stamp of a member of the Syndicate for the purpose of making a Bid in terms of this Prospectus. The Bidder shall have the option to make a maximum of three Bids in the Bid cum Application Form and such options shall not be considered as multiple Bids. Upon the allocation of Equity Shares, dispatch of the CAN, and filing of the Prospectus with the ROC, the Bid cum Application Form shall be considered as the Application Form. Upon completing and submitting the Bid cum Application Form to a member of the Syndicate, the Bidder is deemed to have authorised our Company to make the necessary changes in this Prospectus and the Bid cum Application Form as would be required for filing the Prospectus with the ROC and as would be required by ROC after such filing, without prior or subsequent notice of such changes to the Bidder.

The prescribed colour of the Bid cum Application Form for various categories, is as follows:

### CATEGORY COLOUR OF BID CUM APPLICATION FORM

Category	Colour of Bid cum Application Form
Indian public, NRIs applying on a non-repatriation basis	White
Non-Residents, NRIs or FIIs applying on a repatriation basis	Blue
Employees	Pink

White for Indian public, NRIs applying on a non-repatriation basis Blue for Non-Residents, NRIs, FVCIs, FIIs, etc. applying on a repatriation basis and Pink for Employees.

#### **Who can Bid**

1. Indian nationals resident in India who are majors, or in the names of their minor children as natural/legal guardians, in single or joint names (not more than three);
2. HUFs in the individual name of the Karta. The Bidder should specify that the Bid is being made in the name of the HUF in the Bid cum Application Form as follows: "Name of Sole or First Bidder: XYZ Hindu Undivided Family applying through XYZ, where XYZ is the name of the Karta". Bids by HUFs would be considered at par with those from individuals;
3. Eligible Non-Residents including NRIs on a repatriation basis or a non-repatriation basis subject to applicable laws;
4. Insurance companies registered with the Insurance Regulatory and Development Authority, India;
5. Companies, corporate bodies and societies registered under the applicable laws in India and authorised to invest in equity shares;
6. As permitted by the applicable laws, provident funds with minimum corpus of Rs. 250 million and who are authorised under their constitution to invest in equity shares;
7. Pension funds with a minimum corpus of Rs. 250 million and who are authorised under their constitution to invest in equity shares;
8. Mutual Funds registered with SEBI;
9. Indian financial institutions, commercial banks, regional rural banks, co-operative banks (subject to the RBI regulations and the SEBI guidelines and regulations, as applicable);
10. Multilateral and bilateral development financial institutions;
11. State Industrial Development Corporations;
12. Trusts/societies registered under the Societies Registration Act, 1860, as amended, or under any other law relating to trusts/societies and who are authorised under their constitution to hold and invest in equity shares;
13. FIIs registered with SEBI;
14. Venture capital funds registered with SEBI;
15. Foreign venture capital investors registered with SEBI; and
16. Scientific and/or industrial research organisations authorised to invest in equity shares.
17. Permanent employees or Directors (whole-time Directors, part-time Directors or otherwise) of the Company, who are Indian Nationals and are based in India. The permanent employees should be on the payroll of the Company as of February 27, 2006 and the Directors should be Directors on the date of the Prospectus.

**Note:** Further, the BRLMs and Syndicate Members shall not be entitled to subscribe to this issue in any manner except towards fulfilling their underwriting obligation. Bidders are advised to ensure that any single Bid from them does not exceed the investment limits or maximum number of Equity Shares that can be held by them under applicable law.

#### **Maximum and minimum Bid size**

1. **For Retail Individual Bidders:** The Bid must be for a minimum of 150 Equity Shares and in multiples of 150 Equity Shares thereafter and it must be ensured that the Bid Amount payable by the Bidder does not exceed Rs. 100,000. In case of revision of Bids, the Retail Individual Bidders have to ensure that the Bid Amount does not exceed Rs. 100,000. In case the Bid Amount is over Rs. 100,000 due to revision of the Bid or revision of the Price Band or on exercise of option to bid at Cut-off Price, the Bid would be considered for allocation under the Non Institutional Portion. The option to bid at Cut-off Price is an option given only to the Retail Individual Bidders indicating their agreement to Bid and purchase Equity Shares at the Issue Price as determined at the end of the Book Building Process.

2. **For Non-Institutional Bidders and QIB Bidders:** The Bid must be for a minimum of such number of Equity Shares such that the Bid Amount exceeds Rs. 100,000 and in multiples of 150 Equity Shares. A Bid cannot be submitted for more than the Issue Size. However, the maximum Bid by a QIB investor should not exceed the investment limits prescribed for them by applicable laws. Under existing SEBI guidelines, a QIB Bidder cannot withdraw its Bid after the Bid /Issue Closing Date. In case of revision in Bids, the Non Institutional Bidders, who are individuals, have to ensure that the Bid Amount is greater than Rs. 100,000 for being considered for allocation in the Non Institutional Portion. In case the Bid Amount reduces to Rs. 100,000 or less due to a revision in Bids or revision of the Price Band, Bids by Non Institutional Bidders who are eligible for allocation in the Retail Portion would be considered for allocation under the Retail Portion. Non Institutional Bidders and QIB Bidders are not entitled to the option of bidding at Cut-off Price.
3. **For Bidders in the Employees Reservation Portion:** The Bid must be for a minimum of 150 Equity Shares and in multiples of 150 Equity Shares thereafter. The maximum Bid in this portion cannot exceed Rs. 500 Lacs being 5% of the Issue size. In the event the Bid amount in the Employees Reservation Portion is in excess of Rs. Rs. 500 Lacs, the Bid may be rejected. Bidders in the Employees Reservation Portion applying for an amount of up to Rs. 1,00,000 in any of the bidding options may bid at ‘Cut -off’ Price.

#### **Information for the Bidders:**

1. Our Company will file the Prospectus with the ROC.
2. The members of the Syndicate will circulate copies of the Prospectus along with the Bid cum Application Form to potential investors.
3. Any investor (who is eligible to invest in our Equity Shares) who would like to obtain the Prospectus and/or the Bid cum Application Form can obtain the same from our registered office or from any of the members of the Syndicate.
4. The Bids should be submitted on the prescribed Bid cum Application Form only. Bid cum Application Forms should bear the stamp of a member of the Syndicate. Bid cum Application Forms, which do not bear the stamp of a member of the Syndicate will be rejected.

#### **Method and Process of Bidding**

1. The Syndicate Members shall accept Bids from the Bidders during the Bidding/ Issue Period in accordance with the terms of the Syndicate Agreement.
2. Investors who are interested in subscribing to our Equity Shares should approach any of the members of the Syndicate or their authorised agent(s) to register their Bid.
3. Each Bid cum Application Form will give the Bidder the choice to bid for up to three optional prices (for details please see section titled “Issue Procedure - Bids at Different Price Levels” beginning on page 225 within the Price Band and specify the demand (i.e. the number of Equity Shares bid for) in each option. The price and demand options submitted by the Bidder in the Bid cum Application Form will be treated as optional demands from the Bidder and will not be cumulated. After determination of the Issue Price, the maximum number of Equity Shares Bid for by a Bidder at or above the Issue Price will be considered for allocation and the rest of the Bid(s), irrespective of the Bid Price, will become automatically invalid.
4. The Bidder cannot bid on another Bid cum Application Form after Bids on one Bid cum Application Form have been submitted to a member of the Syndicate. Submission of a second Bid cum Application Form to either the same or to another member of the Syndicate will be treated as multiple Bids and is liable to be rejected either before entering the Bid into the electronic bidding system, or at any point of time prior to the allocation or allotment of Equity Shares in this Issue. However, the Bidder can revise the Bid through the Revision Form, the procedure for which is detailed under the section titled “Issue Procedure - Build up of the book and revision of Bids” beginning on page 225.
5. The Syndicate Members will enter each Bid option into the electronic bidding system as a separate Bid and generate a Transaction Registration Slip (“TRS”), for each price and demand option and give the same to the Bidder. Therefore, a Bidder can receive up to three TRSs for each Bid cum

Application Form. During the Bidding/ Issue Period, Bidders may approach a members of the Syndicate to submit their Bid. Every member of the Syndicate shall accept Bids from all clients/investors who place orders through them and shall have the right to vet the Bids, subject to the terms of the Syndicate Agreement and this Prospectus.

6. Along with the Bid cum Application Form, all Bidders will make payment in the manner described under the paragraph titled “Issue Procedure - Terms of payment and payment into the Escrow Account” beginning on page 225.

#### **Bids at different price levels**

1. The Price Band has been fixed at Rs. 37/- to Rs. 42/- per Equity Share of Rs. 10 each, Rs. 37/- being the Floor Price and Rs. 42/- being the Cap Price. The Bidders can bid at any price within the Price Band, in multiples of Re. 1.
2. In accordance with the SEBI Guidelines, our Company reserves the right to revise the Price Band during the Bidding/ Issue Period. The cap on the Price Band should not be more than 20% of the floor of the Price Band. Subject to compliance with the immediately preceding sentence, the floor of the Price Band can move up or down to the extent of 20% of the floor of the Price Band.
3. In case of revision in the Price Band, the Bidding/ Issue Period will be extended for three additional days after revision of Price Band subject to a maximum of 10 working days. Any revision in the Price Band and the revised Bidding /Issue Period, if applicable, will be widely disseminated by notification to the BSE and the NSE, by issuing a public notice in two national newspapers (one each in English and Hindi) and a regional newspaper, and also by indicating the change on the websites of the BRLMs and at the terminals of the members of the Syndicate.
4. We, in consultation with the BRLMs, can finalise the Issue Price within the Price Band in accordance with this clause, without the prior approval of, or intimation to, the Bidders.
5. The Bidder can bid at any price within the Price Band. The Bidder has to bid for the desired number of Equity Shares at a specific price. Retail Individual Bidders applying for a maximum amount of Rs. 100,000 may also bid at “Cut-off”. Employees applying for a maximum Bid in any of the bidding options not exceeding up to Rs.1,00,000/-may also bid at “Cut-off”. However, bidding at “Cut-off” is prohibited for QIB or Non Institutional Bidders who bid for an amount exceeding Rs.100,000, and such Bids shall be rejected.
6. Bidders who bid at Cut-off Price agree that they shall purchase the Equity Shares at any price within the Price Band. Bidders bidding at Cut-Off shall deposit the Bid Amount based on the Cap Price in the Escrow Account. In the event the Bid Amount is higher than the subscription amount payable by the Bidders, who Bid at Cut-Off (i.e. the total number of Equity Shares allocated in the Issue multiplied by the Issue Price), the Bidders who Bid at Cut-off, shall receive the refund of the excess amounts from the Escrow Account.
7. In case of an upward revision in the Price Band announced as above, Retail Individual Bidders, who had bid at Cut-Off could either (i) revise their Bid or (ii) make additional payment based on the cap of the revised Price Band (such that the total amount i.e. original Bid Amount plus additional payment does not exceed Rs. 100,000 if the Bidder wants to continue to bid at Cut-off Price), with the Syndicate Member to whom the original Bid was submitted. In case the total amount (i.e. original Bid Amount plus additional payment) exceeds Rs. 100,000, the Bid will be considered for allocation under the Non-Institutional Portion in terms of this Prospectus. If, however, the Bidder does not either revise the Bid or make additional payment and the Issue Price is higher than the cap of the Price Band prior to revision, the number of Equity Shares bid for shall be adjusted downwards for the purpose of allotment, such that no additional payment would be required from the Bidder and the Bidder is deemed to have approved such revised Bid at Cut-off.
8. In case of a downward revision in the Price Band, announced as above, Retail Individual Bidders and Employees bidding as part of the Employees Reservation Portion, who have bid at Cut-off Price, could either revise their Bid or the excess amount paid at the time of bidding would be refunded from the Escrow Account.
9. In the event of any revision in the Price Band, whether upwards or downwards, the minimum application size shall remain 150 Equity Shares irrespective of whether the Bid Amount payable on such minimum application is not in the range of Rs. 5,000 to Rs. 7,000.

## **Application in the Issue**

Equity Shares being issued through the Prospectus can be applied for in the dematerialized form only.

## **Bids by Mutual Funds**

An eligible Bid by a Mutual Fund shall first be considered for allocation proportionately in the Mutual Fund Portion. In the event that the demand is greater than 641,892 Equity Shares, Allocation shall be made to Mutual Funds proportionately, to the extent of the Mutual Funds Portion. The remaining demand by Mutual Funds shall, as part of the aggregate demand by QIBs, be made available for allocation proportionately out of the remainder of the QIB Portion, after excluding the allocation in the Mutual Fund Portion.

## **Multiple Bids**

In case of a Mutual Fund, a separate Bid can be made in respect of each scheme of the Mutual Fund registered with SEBI and such Bids in respect of more than one scheme of the Mutual Fund will not be treated as multiple Bids provided that the Bids clearly indicate the scheme for which the Bid has been made.

*As per the current regulations, the following restrictions are applicable for investments by Mutual Funds:*

No Mutual Fund scheme shall invest more than 10% of its net asset value in equity shares or equity related instruments of any company provided that the limit of 10% shall not be applicable for investments in index funds or sector or industry specific funds. No Mutual Fund under all its schemes should own more than 10% of any company's paid-up capital carrying voting rights.

The above information is given for the benefit of the Bidders. Our Company and the BRLMs are not liable for any amendments or modification or changes in applicable laws or regulations, which may happen after the date of this Prospectus. Bidders are advised to make their independent investigations and ensure that the number of Equity Shares bid for do not exceed the applicable limits under laws or regulations.

## **Bids by NRIs**

NRI Bidders to comply with the following:

1. Individual NRI Bidders can obtain the Bid cum Application Forms from our Registered Office, our corporate office, members of the Syndicate or the Registrar to the Issue.
2. NRI Bidders may please note that only such Bids as are accompanied by payment in free foreign exchange shall be considered for allotment. NRIs who intend to make payment through Non-Resident Ordinary (NRO) accounts shall use the Bid cum Application Form meant for resident Indians (White in color).

## **Escrow Mechanism**

We shall open Escrow Accounts with one or more Escrow Collection Banks in whose favour the Bidders shall make out the cheque or demand draft in respect of his or her Bid and/or revision of the Bid. Cheques or demand drafts received for the full Bid Amount from Bidders would be deposited in the Escrow Account. The Escrow Collection Banks will act in terms of the Prospectus and the Escrow Agreement. The monies in the Escrow Account shall be maintained by the Escrow Collection Bank(s) for and on behalf of the Bidders. The Escrow Collection Bank(s) shall not exercise any lien whatsoever over the monies deposited therein and shall hold the monies therein in trust for the Bidders. On the Designated Date, the Escrow Collection Banks shall transfer the monies from the Escrow Account to the Issue Account as per the terms of the Escrow Agreement. Payments of refund to the Bidders shall also be made from the Escrow Account as per the terms of the Escrow Agreement and this Prospectus.

The Bidders should note that the escrow mechanism is not prescribed by SEBI and has been established as an arrangement between us, the Syndicate, the Escrow Collection Bank(s) and the Registrar to the Issue to facilitate collections from the Bidders.

### **Terms of payment and payment into the Escrow Accounts**

Each Bidder, shall pay the applicable Margin Amount, with the submission of the Bid cum Application Form draw a cheque or demand draft for the maximum amount of his/ her Bid in favour of the Escrow Account of the Escrow Collection Bank(s) (for details please see the section titled “Issue Procedure - Payment Instructions” beginning on page 225 and submit the same to the member of the Syndicate to whom the Bid is being submitted. Bid cum Application Forms accompanied by cash shall not be accepted. The maximum Bid price has to be paid at the time of submission of the Bid cum Application Form based on the highest bidding option of the Bidder.

The members of the Syndicate shall deposit the cheque or demand draft with the Escrow Collection Bank(s), which will hold the monies for the benefit of the Bidders till the Designated Date. On the Designated Date, the Escrow Collection Bank(s) shall transfer the funds equivalent to the size of the Issue from the Escrow Account, as per the terms of the Escrow Agreement, into the Issue Account of the Company with the Banker(s) to the Issue. The balance amount after transfer to the Issue Account of the Company shall be held for the benefit of the Bidders who are entitled to refunds on the Designated Date, and no later than 15 days from the Bid /Issue Closing Date, the Escrow Collection Bank(s) shall refund all monies to unsuccessful Bidders and also the excess amount paid on bidding, if any, after adjustment for allotment to the Bidders.

Each category of Bidders i.e. QIB Bidders, Non Institutional Bidders, Retail Individual Bidders and the Employees would be required to pay their applicable Margin Amount at the time of the submission of the Bid cum Application Form. The Margin Amount payable by each category of Bidders is mentioned in the section titled “Issue Structure” on page 223.

Where the Margin Amount applicable to the Bidder is less than 100% of the Bid Amount, any difference between the amount payable by the Bidder for Equity Shares allocated at the Issue Price and the Margin Amount paid at the time of Bidding, shall be payable by the Bidder no later than the Pay-in-Date, which shall be a minimum period of two days from the date of communication of the allocation list to the members of the Syndicate by the BRLMs. If the payment is not made favouring the Escrow Account within the time stipulated above, the Bid of the Bidder is liable to be cancelled.

However, if the members of the Syndicate do not waive such payment, the full amount of payment has to be made at the time of submission of the Bid cum Application Form.

Where the Bidder has been allocated lesser number of Equity Shares than he or she had bid for, the excess amount paid on bidding, if any, after adjustment for allotment, will be refunded to such Bidder within 15 days from the Bid /Issue Closing Date, failing which we shall pay interest at 15% per annum for any delay beyond the periods as mentioned above.

### **Electronic registration of Bids**

1. The Syndicate Members will register the Bids using the on-line facilities of the BSE and the NSE. There will be at least one on-line connectivity in each city, where a stock exchange is located in India and where Bids are being accepted.
2. The BSE and the NSE will offer a screen-based facility for registering Bids for the Issue. This facility will be available on the terminals of the Syndicate Members and their authorised agents during the Bidding/Issue Period. The Syndicate Members can also set up facilities for off-line electronic registration of Bids subject to the condition that they will subsequently download the off-line data file into the on-line facilities for book building on a regular basis. On the Bid /Issue Closing Date, the Syndicate Members shall upload the Bids till such time as may be permitted by the Stock Exchanges.

3. The aggregate demand and price for Bids registered on the electronic facilities of the BSE and the NSE displayed online at all bidding centers and at the website of BSE and NSE. A graphical representation of consolidated demand and price would be made available at the bidding centers during the Bidding/ Issue Period.
4. At the time of registering each Bid, the members of the Syndicate shall enter the following details of the investor in the on-line system:
  - (a) Name of the investor
  - (b) Investor category – individual, corporate, NRI, FII, or Mutual Fund etc.
  - (c) Numbers of Equity Shares bid for
  - (d) Bid price
  - (e) Bid cum Application Form number
  - (f) Whether Margin Amount has been made upon submission of Bid cum Application Form
  - (g) Depository participant identification no. and client identification no. of the beneficiary account of the Bidder
5. A system generated TRS will be given to the Bidder as a proof of the registration of each of the bidding options. **It is the Bidder's responsibility to obtain the TRS from the members of the Syndicate.** The registration of the Bid by the member of the Syndicate does not guarantee that the Equity Shares shall be allocated either by the members of the Syndicate or our Company.
6. Such TRS will be non-negotiable and by itself will not create any obligation of any kind.
7. It is to be distinctly understood that the permission given by the BSE and the NSE to use their network and software of the Online IPO system should not in any way be deemed or construed to mean that the compliance with various statutory and other requirements by our Company or the BRLMs are cleared or approved by the BSE and the NSE; nor does it in any manner warrant, certify or endorse the correctness or completeness of compliance with the statutory and other requirements nor does it take any responsibility for the financial or other soundness of our Company, our Promoters, our management or any scheme or project of our Company.
8. It is also to be distinctly understood that the approval given by the BSE and the NSE should not in any way be deemed or construed that this Prospectus has been cleared or approved by the BSE and the NSE; nor does it in any manner warrant, certify or endorse the correctness or completeness of any of the contents of this Prospectus; nor does it warrant that our Equity Shares will be listed or will continue to be listed on the BSE and the NSE.

#### **Build up of the book and revision of Bids**

1. Bids of various Bidders/ registered through the Syndicate Members shall be electronically transmitted to the BSE or the NSE mainframe on a regular basis.
2. The book gets built up at various price levels. This information will be available with the BRLMs on a regular basis.
3. During the Bidding /Issue Period, any Bidder who has registered his or her interest in the Equity Shares at a particular price level is free to revise his or her Bid within the Price Band during the Bidding /Issue Period using the printed Revision Form which is a part of the Bid cum Application Form.
4. Revisions can be made in both the desired number of Equity Shares and the Bid price by using the Revision Form. Apart from mentioning the revised options in the Revision Form, the Bidder must also mention the details of all the options in his or her Bid cum Application Form or earlier Revision Form. For example, if a Bidder has Bid for three options in the Bid cum Application Form and he is changing only one of the options in the Revision Form, he must still fill the details of the other two options that are not being changed in the Revision Form. Incomplete or inaccurate Revision Forms will not be accepted by the members of the Syndicate.
5. The Bidder can make this revision any number of times during the Bidding/ Issue Period. However, for any revision(s) in the Bid, the Bidders will have to use the services of the same member of the Syndicate through whom he or she had placed the original Bid. **Bidders are advised to retain copies of the blank Revision Form and the revised Bid must be made only in such Revision Form or copies thereof.**
6. Any revision of the Bid shall be accompanied by payment in the form of cheque or demand draft for the incremental amount, if any, to be paid on account of the upward revision of the Bid. The

- excess amount, if any, resulting from downward revision of the Bid would be returned to the Bidder at the time of refund in accordance with the terms of this Prospectus. In case of QIB Bidders, the members of the Syndicate shall collect the payment in the form of cheque or demand draft for the incremental amount in the QIB Margin Amount, if any, to be paid on account of upward revision of the Bid at the time of one or more revisions by the QIB Bidders.
7. When a Bidder revises his or her Bid, he or she shall surrender the earlier TRS and get a revised TRS from the members of the Syndicate. **It is the responsibility of the Bidder to request for and obtain the revised TRS, which will act as proof of his or her having revised the previous Bid.**
  8. Only Bids that are uploaded on the online IPO system of the NSE and BSE shall be considered for Allocation. In case of discrepancy of data between the BSE or the NSE and the members of the Syndicate, the decision of the BRLMs, based on the physical records of Bid cum Application Forms, shall be final and binding on all concerned.

### **Price Discovery and Allocation**

1. After the Bid/Issue Closing Date, the BRLM shall analyze the demand generated at various price levels and discuss pricing strategy with us.
2. Our Company in consultation with the BRLM, shall finalize the “Issue Price” (and the number of Equity Shares to be allocated in each investor category).
3. The allocation for QIBs for at least 50% of the Net Issue would be on a proportionate basis (with a minimum 5% allocation of the QIB Portion reserved for Mutual Funds, and such Mutual Funds can participate in the remaining allocation for QIBs), in consultation with the Designated Stock Exchange subject to valid Bids being received at or above the Issue Price, in the manner as described in the section titled “Basis of Allotment – Allotment to QIB Bidders”. If at least 50% of the Net Issue cannot be allotted to QIBs, then the entire application money will be refunded. The allocation to Non-Institutional Bidders and Retail Individual Bidders of upto 15% and 35% of the Net Issue respectively, would be on proportionate basis, in the manner specified in the SEBI Guidelines, in consultation with Designated Stock Exchange, subject to valid Bids being received at or above the Issue Price. The allocation under the Employees Reservation Portion for up to 5% of the Issue each would be on proportionate basis, in the manner specified in the SEBI Guidelines, in consultation with Designated Stock Exchange, subject to valid Bids being received at or above the Issue Price.
4. Under subscription, if any, in Non-Institutional and Retail categories would be allowed to be met with spill over from any of the other categories at the discretion of the Company, in consultation with the BRLM and the Designated Stock Exchange. However, if the aggregate demand by Mutual Funds is less than 641,892 Equity Shares, the balance Equity Shares from 5% specifically available for allocation to Mutual Funds in the QIB Portion will first be added to the QIB Portion and be allocated proportionately to the QIB Bidders in proportion to their Bids. Any under subscription in the Equity Shares reserved for allocation to Bidders in the Employee Reservation Portion would be treated as part of the Net Issue to the public.
5. The BRLM, in consultation with our Company, shall notify the members of the Syndicate of the Issue Price and allocations to their respective Bidders, where the full Bid Amount has not been collected from the Bidders.
6. Allotment to Eligible NRIs, FIIs registered with SEBI or Mutual Funds or FVCIs registered with SEBI will be subject to applicable laws, rules, regulations, guidelines and approvals.
7. We reserve the right to cancel the Issue any time after the Bid/Issue Opening Date but before the Allotment without assigning any reasons whatsoever.
8. In terms of the SEBI Guidelines, QIBs shall not be allowed to withdraw their Bid after the Bid/Issue Closing Date.

### **Signing of Underwriting Agreement and ROC Filing**

1. We, , the BRLMs and the Syndicate Members shall enter into an Underwriting Agreement on finalisation of the Issue Price.

2. After signing the Underwriting Agreement, we would update and file the updated Prospectus with ROC, which then would be termed 'Prospectus'. The Prospectus would have details of the Issue Price and Issue size and would be complete in all material respects.

### **Advertisement regarding Issue Price and Prospectus**

A statutory advertisement will be issued by our Company after the filing of the Prospectus with the ROC. This advertisement, in addition to the information that has to be set out in the statutory advertisement, shall indicate the Issue Price. Any material updates between the date of Prospectus and the date of Prospectus will be included in such statutory advertisement.

### **Issuance of CAN**

1. Upon approval of the basis of allotment by the Designated Stock Exchange, the BRLMs or the Registrar to the Issue shall send to the members of the Syndicate a list of their Bidders who have been allocated Equity Shares in the Issue. The approval of allocation by the Designated Stock Exchange for QIB Bidders may be done simultaneously with or prior to the approval of the basis of allocation for the Retail and Non-Institutional Bidders and the Employee Reservation Category. However, Bidders should note that the Company shall ensure that the date of Allotment of the Equity Shares to all Bidders, in all categories, shall be done on the same date.
2. The BRLMs or the members of the Syndicate would then send the CAN to their Bidders who have been allocated Equity Shares in the Issue. The dispatch of a CAN shall be deemed a valid, binding and irrevocable contract for the Bidder to pay the entire Issue Price for all the Equity Shares Allocated to such Bidder. Those Bidders who have paid the Margin Amount being less than the Bid Amount into the Escrow Account at the time of bidding shall pay in the bidding shall pay in full the amount payable balance amount into the Escrow Account by the Pay-in Date specified in the CAN.
3. Bidders who have been allocated Equity Shares and who have already paid into the Escrow Account at the time of bidding shall directly receive the CAN from the Registrar to the Issue subject, however, to realisation of their cheque or demand draft paid into the Escrow Account. The dispatch of a CAN shall be deemed as a valid, binding and irrevocable contract for the Bidder to pay the entire Issue Price for all the Equity Shares to be allotted to such Bidder.

### **Designated Date and Allotment of Equity Shares**

1. Our Company will ensure that the Allotment of Equity Shares is done within 15 days of the Bid /Issue Closing Date. After the funds are transferred from the Escrow Account to the Issue Account on the Designated Date, our Company would ensure the credit to the successful Bidders' depository accounts of the allotted Equity Shares to the allottees within two working days from the date of Allotment.
2. As per section 68B of the Companies Act, **Equity Shares will be issued and allotted only in the dematerialised form to the allottees.** Allottees will have the option to re-materialise the Equity Shares so allotted, if they so desire, as per the provisions of the Companies Act and the Depositories Act. **Investors are advised to instruct their Depository Participant to accept the Equity Shares that may be allocated to them pursuant to this Issue.**

### **LETTERS OF ALLOTMENT OR REFUND ORDERS**

We shall give credit to the beneficiary account with Depository Participants within two working days from the date of the Allotment. We shall ensure dispatch of refund orders, if any, of value up to Rs. 1,500 by "Under Certificate of Posting", and shall dispatch refund orders above Rs. 1,500, if any, by registered post at the sole or First Bidder's sole risk within 15 days of the Bid /Issue Closing Date. Adequate Funds will be made available to the Registrar to the Issue by the Company for this purpose.

In accordance with the Companies Act, the requirements of the Stock Exchanges and SEBI Guidelines, we undertake that:

1. Allotment shall be made only in dematerialised form within 15 days from the Bid /Issue Closing Date;
2. Dispatch of refund orders shall be done within 15 days from the Bid /Issue Closing Date; and
3. We shall pay interest at 15% per annum (for any delay beyond the 15 day time period as mentioned above), if Allotment is not made, refund orders are not dispatched and/or demat credits are not made to investors within the 15 day time prescribed above.

### GENERAL INSTRUCTIONS

#### Do's:

1. Check if you are eligible to apply.
2. Read all the instructions carefully and complete the Bid cum Application Form (white, blue or pink in colour) as the case may be.
3. Ensure that the details about your Depository Participant and beneficiary account are correct as Equity Shares will be allotted in the dematerialized form only.
4. Ensure that the Bids are submitted at the bidding centers only on forms bearing the stamp of a member of the Syndicate.
5. Ensure that you have been given a TRS for all your Bid options.
6. Submit Revised Bids to the same member of the Syndicate through whom the original Bid was placed and obtain a revised TRS.
7. Where Bid(s) is/are for Rs. 50,000 or more, each of the Bidders, should mention their Permanent Account Number (PAN) allotted under the IT Act. The copies of the PAN card or PAN allotment letter should be submitted with the application form. If you have mentioned "Applied For" or "Not Applicable", in the Bid cum Application Form in the section dealing with PAN number, ensure that you submit Form 60 or 61, as the case may be, together with permissible documents as address proof.
8. Ensure that the name(s) given in the Bid cum Application Form is exactly the same as the name(s) in which the beneficiary account is held with the Depository Participant. In case the Bid cum Application Form is submitted in joint names, ensure that the beneficiary account is also held in same joint names and such names are in the same sequence in which they appear in the Bid cum Application Form.

#### Don'ts:

1. Do not Bid for lower than the minimum Bid size.
2. Do not Bid/revise Bid price to less than the lower end of the Price Band or higher than the higher end of the Price Band.
3. Do not Bid on another Bid cum Application Form after you have submitted a Bid to the members of the Syndicate.
4. Do not pay the Bid amount in cash, by money order or by postal order or by stock invest.
5. Do not send Bid cum Application Forms by post; instead submit the same to a member of the Syndicate only.
6. Do not Bid at Cut-Off (for Employees bidding for an amount above Rs. 1,00,000, QIB Bidders and Non-Institutional Bidders).
7. Do not fill up the Bid cum Application Form such that the Equity Shares bid for exceeds the Issue size and/or investment limit or maximum number of Equity Shares that can be held under the applicable laws or regulations or maximum amount permissible under the applicable regulations.
8. **Do not submit the GIR number instead of the PAN as the Bid is liable to be rejected on this ground.**

### INSTRUCTIONS FOR COMPLETING THE BID CUM APPLICATION FORM

Bidders can obtain Bid cum Application Forms and/or Revision Forms from the members of the Syndicate.

### **Bids and Revisions of Bids**

Bids and revisions of Bids must be:

1. Made only in the prescribed Bid cum Application Form or Revision Form, as applicable (White, Blue or Pink colour).
2. In single or in joint names (not more than three, and in the same order as their Depository Participant details).
3. Completed in full, in BLOCK LETTERS in ENGLISH and in accordance with the instructions contained herein, in the Bid cum Application Form or in the Revision Form. Incomplete Bid cum Application Forms or Revision Forms are liable to be rejected.
4. The Bids from the Retail Individual Bidders must be for a minimum of 150 Equity Shares and in multiples of 150 Equity Shares thereafter subject to a maximum Bid Amount of Rs. 100,000.
5. For Non-Institutional Bidders and QIB Bidders, Bids must be for a minimum of such number of Equity Shares such that the Bid Amount exceeds Rs. 100,000 and in multiples of 150 Equity Shares. Bids cannot be made for more than the Issue size. Bidders are advised to ensure that a single Bid from them should not exceed the investment limits or maximum number of shares that can be held by them under the applicable laws or regulations.
6. For Employees Reservation Portion, the Bid must be for a minimum of 150 Equity Shares and in multiples of 150 Equity Shares thereafter, subject to the maximum Bid Amount not exceeding 5% of the Issue Amount. In the event the Bid amount in the Employees Reservation Portion is in excess of the applicable limit, the Bid may be rejected. In single name or in joint names (not more than three, and in the same order as their Depository Participant details).
7. Thumb impressions and signatures other than in the languages specified in the Eighth Schedule in the Constitution of India must be attested by a Magistrate or a Notary Public or a Special Executive Magistrate under official seal.

### **Bids by Employees in the Employees Reservation Portion**

For the sake of clarity, the term “Employees” shall mean all or any of the following all of whom should be Indian Nationals and are based in India:

- (i) a permanent employee of the Company and on the payroll of the Company as of February 27, 2006.
- (ii) a Director of the Company, whether a whole-time Director, part time Director or otherwise, who is a Director on the date of the Prospectus.

1. Bids by Employees shall be made only in the prescribed Bid cum Application Form or Revision Form (i.e., pink color form).
2. Employees should mention their Employee Number at the relevant place in the Bid cum Application Form.
3. The sole/First Bidder should be an Employee as defined above. In case the Bid cum Application Form is submitted in joint names, it should be ensured that the Depository Account is also held in the same joint names and in the same sequence in which they appear in the Bid cum Application Form.
4. Only permanent employees on the payroll of the Company as on the cut-off date i.e. February 27, 2006 and Directors of the Company as of the date of the Prospectus would be eligible to apply in this Issue under reservation for Employees on a competitive basis.
5. Employees will have to Bid like any other Bidder. Only those Bids, which are received at or above the Issue Price, would be considered for allotment under this category.
6. If the aggregate demand in this category is less than or equal to 1351351 Equity Shares at or above the Issue Price, full allocation shall be made to the Employees to the extent of their demand. Any under subscription in Equity Shares reserved for Employees would be treated as part of the Net Issue and proportionate allocation of the same would be at the sole discretion of the Company in consultation with the BRLM and the Designated Stock Exchange.

7. If the aggregate demand in this category is greater than 1351351 Equity Shares at or above the Issue Price, the allocation shall be made on a proportionate basis.
8. Bidding at Cut-off is allowed only for Employees whose Bid Amount is less than or equal to Rs.100,000. Bids made by Employees both under Employee Reservation Portion as well as in the Net Issue shall not be treated as multiple bids.

#### **Bidder's depository account details**

**IT IS MANDATORY FOR ALL THE BIDDERS TO GET THE EQUITY SHARES IN DEMATERIALIZED FORM. ALL BIDDERS SHOULD MENTION THEIR DEPOSITORY PARTICIPANT'S NAME, DEPOSITORY PARTICIPANT IDENTIFICATION NUMBER AND BENEFICIARY ACCOUNT NUMBER IN THE BID CUM APPLICATION FORM. INVESTORS MUST ENSURE THAT THE NAME GIVEN IN THE BID CUM APPLICATION FORM IS EXACTLY THE SAME AS THE NAME IN WHICH THE DEPOSITORY ACCOUNT IS HELD. IN CASE THE BID CUM APPLICATION FORM IS SUBMITTED IN JOINT NAMES, IT SHOULD BE ENSURED THAT THE DEPOSITORY ACCOUNT IS ALSO HELD IN THE SAME JOINT NAMES AND ARE IN THE SAME SEQUENCE IN WHICH THEY APPEAR IN THE BID CUM APPLICATION FORM.**

**Bidders should note that on the basis of name of the Bidders, Depository Participant's name and identification number and beneficiary account number provided by them in the Bid cum Application Form, the Registrar to the Issue will obtain from the Depository demographic details of the Bidders such as address, bank account details for printing on refund orders and occupation ("Demographic Details"). Hence, Bidders should carefully fill in their Depository Account details in the Bid cum Application Form.**

By signing the Bid cum Application Form, the Bidder would be deemed to have authorised the Depositories to provide, upon request, to the Registrar to the Issue, the required Demographic Details as available on its records.

**Refund orders/allocation advices/CANs would be mailed at the address of the Bidder as per the Demographic Details received from the Depositories. Bidders may note that delivery of refund orders/allocation advice/CANs may get delayed if the same once sent to the address obtained from the Depositories are returned undelivered. In such an event, the address and other details given by the Bidder in the Bid cum Application Form would be used only to ensure dispatch of refund orders. Please note that any such delay shall be at the Bidders sole risk and neither the Escrow Collection Bank(s) nor the BRLMs shall be liable to compensate the Bidder for any losses caused to the Bidder due to any such delay or liable to pay any interest for such delay.**

In case no corresponding record is available with the Depositories that matches three parameters, namely, names of the Bidders (including the order of names of joint holders), the Depository Participant's identity (DP ID) and the beneficiary account number, then such Bids are liable to be rejected.

#### **Bidder's bank details**

Bidders should note that on the basis of name of the Bidders, Depository Participant's name and identification number and the beneficiary account number provided by them in the Bid cum Application Form, the Registrar to the Issue will obtain from the Depository the details of the Bidder's bank account. **These bank account details would be printed on the refund order, if any, to be sent to Bidders. Hence, Bidders are advised to immediately update their bank account details as appearing on the records of the Depository Participant.** Please note that failure to do so could result in delays in credit of refunds to Bidders at the Bidders sole risk and neither the BRLMs nor the Company shall have any responsibility and undertake any liability for the same.

### **Bids under Power of Attorney**

In case of Bids made pursuant to a power of attorney or by limited companies, corporate bodies, registered societies, a certified copy of the power of attorney or the relevant resolution or authority, as the case may be, along with a certified copy of the memorandum and articles of association and/or bye laws must be lodged along with the Bid cum Application Form. Failing this, our Company reserves the right to accept or reject any Bid in whole or in part, in either case, without assigning any reason therefor.

In case of the Bids made pursuant to a power of attorney by FIIs, a certified copy of the power of attorney or the relevant resolution or authority, as the case may be, along with a certified copy of their SEBI registration certificate must be lodged along with the Bid cum Application Form. Failing this, our Company reserves the right to accept or reject any Bid in whole or in part, in either case, without assigning any reason therefor.

In case of the Bids made by insurance companies registered with the Insurance Regulatory and Development Authority, a certified copy of certificate of registration issued by Insurance Regulatory and Development Authority must be lodged along with the Bid cum Application Form. Failing this, our Company reserves the right to accept or reject any Bid in whole or in part, in either case, without assigning any reason therefor.

In case of the Bids made by provident funds, subject to applicable law, with minimum corpus of Rs. 250 million and pension funds with minimum corpus of Rs. 250 million, a certified copy of certificate from a chartered accountant certifying the corpus of the provident fund/pension fund must be lodged along with the Bid cum Application Form. Failing this, our Company reserves the right to accept or reject any Bid in whole or in part, in either case, without assigning any reason therefor.

We, in our absolute discretion, reserve the right to relax the above condition of simultaneous lodging of the power of attorney along with the Bid cum Application Form, subject to such terms and conditions that we/the BRLMs may deem fit.

We, in our absolute discretion, reserve the right to permit the holder of the power of attorney to request the Registrar that for the purpose of printing particulars on the refund order and mailing of the refund order/CANs/allocation advice, the Demographic Details given on the Bid cum Application Form should be used (and not those obtained from the Depository of the Bidder). In such cases, the Registrar shall use Demographic Details as given in the Bid cum Application Form instead of those obtained from the depositories.

### **Bids by Non-Residents, NRIs and FIIs on a repatriation basis**

Bids and revision to the Bids must be made:

1. On the Bid cum Application Form or the Revision Form, as applicable (blue in color), and completed in full in BLOCK LETTERS in ENGLISH in accordance with the instructions contained therein.
2. In a single name or joint names (not more than three).
3. NRIs for a Bid Amount of up to Rs. 100,000 would be considered under the Retail Portion for the purposes of allocation and Bids for a Bid Amount of more than Rs. 100,000 would be considered under Non-Institutional Portion for the purposes of allocation; by other eligible Non-Resident Bidders for a minimum of such number of Equity Shares and in multiples of 150 thereafter that the Bid Amount exceeds Rs. 100,000. For further details please see section titled "Issue Procedure - Maximum and minimum Bid size" beginning on page 225.
4. In the names of individuals, or in the names of FIIs, FVCIs, etc but not in the names of minors, OCBs, firms or partnerships, foreign nationals (excluding NRIs) or their nominees.

Refunds, dividends and other distributions, if any, will be payable in Indian Rupees only, net of bank charges and/or commission. In case of Bidders who remit money through Indian Rupee drafts purchased

abroad, such payments in Indian Rupees will be converted into U.S. Dollars or any other freely convertible currency as may be permitted by the RBI at the rate of exchange prevailing at the time of remittance and will be dispatched by registered post or if the Bidders so desire, will be credited to their Non-Resident External (NRE) accounts, details of which should be furnished in the space provided for this purpose in the Bid cum Application Form. We will not be responsible for loss, if any, incurred by the Bidder on account of conversion of foreign currency.

It is to be distinctly understood that there is no reservation for Non-Residents, NRIs and FIIs and all Non-Residents, NRI and FII applicants will be treated on the same basis with other categories for the purpose of allocation. As per the existing policy of the government of India, OCBs cannot participate in this Issue.

## **PAYMENT INSTRUCTIONS**

We shall open Escrow Accounts with the Escrow Collection Bank(s) for the collection of the Bid Amounts payable upon submission of the Bid cum Application Form and for amounts payable pursuant to allocation in the Issue.

Each Bidder shall draw a cheque or demand draft for the amount payable on the Bid and/or on allocation as per the following terms:

### **Payment into Escrow Account**

1. The Bidders for whom the applicable margin is equal to 100% shall, with the submission of the Bid cum Application Form draw a payment instrument for the Bid Amount in favour of the Escrow Account and submit the same to the members of the Syndicate.
2. In case the above Margin Amount paid by the Bidders during the Bidding/ Issue Period is less than the Issue Price multiplied by the Equity Shares allocated to the Bidder, the balance amount shall be paid by the Bidders into the Escrow Account within the period specified in the CAN which shall be subject to a minimum period of two days from the date of communication of the allocation list to the members of the Syndicate by the BRLMs.
3. The payment instruments for payment into the Escrow Account should be drawn in favour of:
  - (a) In case of resident QIB Bidders: "Escrow Account- Adhunik Public Issue- QIB-R"
  - (b) In case of non resident QIB Bidders: "Escrow Account- Adhunik Public Issue- QIB-NR"
  - (c) In case of Resident Bidders: "Escrow Account – Adhunik Public Issue"
  - (d) In case of Non-Resident Bidders: "Escrow Account – Adhunik Public Issue - NR"
  - (e) In case of Employees: "Escrow Account – Adhunik Public Issue – Employee"
    - (i) In case of Bids by NRIs applying on repatriation basis, the payments must be made through Indian Rupee drafts purchased abroad or cheques or bank drafts, for the amount payable on application remitted through normal banking channels or out of funds held in NRE accounts or Foreign Currency Non-Resident (FCNR) accounts, maintained with banks authorised to deal in foreign exchange in India, along with documentary evidence in support of the remittance. Payment will not be accepted out of Non-Resident Ordinary (NRO) Account of Non-Resident Bidder bidding on a repatriation basis. Payment by drafts should be accompanied by bank certificate confirming that the draft has been issued by debiting to NRE or FCNR account.
    - (ii) In case of Bids by FIIs, the payment should be made out of funds held in Special Rupee Account along with documentary evidence in support of the remittance. Payment by drafts should be accompanied by bank certificate confirming that the draft has been issued by debiting to a Special Rupee Account.
4. Where a Bidder has been allocated a lesser number of Equity Shares than the Bidder has Bid for, the excess amount, if any, paid on bidding, after adjustment towards the balance amount payable on the Equity Shares allocated, will be refunded to the Bidder from the Escrow Account.

5. The monies deposited in the Escrow Account will be held for the benefit of the Bidders till the Designated Date.
6. On the Designated Date, the Escrow Collection Banks shall transfer the funds from the Escrow Account as per the terms of the Escrow Agreement into the Issue Account.
7. On the Designated Date and not later than 15 days from the Bid /Issue Closing Date, the Escrow Collection Banks shall refund all amounts payable to unsuccessful Bidders and the excess amount paid on Bidding, if any, after adjusting for allocation to the Bidders.

Payments should be made by cheque, or demand draft drawn on any bank (including a co-operative bank), which is situated at, and is a member of or sub member of the banker's clearing house located at the centre where the Bid cum Application Form is submitted. Outstation cheques/bank drafts drawn on banks not participating in the clearing process will not be accepted and applications accompanied by such cheques or bank drafts are liable to be rejected. Cash/ stockinvest/moneyorders/postal orders will not be accepted.

#### **Payment by Stockinvest**

In terms of the Reserve Bank of India Circular No. DBOD No. FSC BC 42/24.47.00/2003-04 dated November 5, 2003, the option to use the stockinvest instrument in lieu of cheques or bank drafts for payment of Bid money has been withdrawn.

#### **SUBMISSION OF BID CUM APPLICATION FORM**

All Bid cum Application Forms or Revision Forms duly completed and accompanied by account payee cheques or drafts equivalent to the Margin Amount shall be submitted to the members of the Syndicate at the time of submission of the Bid.

Separate receipts shall not be issued for the money payable on the submission of Bid cum Application Form or Revision Form. However, the collection center of the members of the Syndicate will acknowledge the receipt of the Bid cum Application Forms or Revision Forms by stamping and returning to the Bidder the acknowledgement slip. This acknowledgement slip will serve as the duplicate of the Bid cum Application Form for the records of the Bidder.

#### **OTHER INSTRUCTIONS**

##### **Joint Bids in case of Individuals**

Bids may be made in single or joint names (not more than three). In case of joint Bids, all payments will be made out in favour of the Bidder whose name appears first in the Bid cum Application Form or Revision Form. All communication will be addressed to the first Bidder and will be dispatched to his or her address as per the Demographic Details received from the Depository.

##### **Multiple Bids**

A Bidder should submit only one Bid (and not more than one) for the total number of Equity Shares required. Two or more Bids will be deemed to be multiple Bids if the sole or First Bidder is one and the same.

In case of a Mutual Fund, a separate Bid can be made in respect of each scheme of the Mutual Fund registered with SEBI and such Bids in respect of more than one scheme of the Mutual Fund will not be treated as multiple Bids provided that the Bids clearly indicate the scheme for which the Bid has been made.

Bids made by Employees both under Employees Reservation Portion as well as in the Net Issue shall not be treated as multiple Bids. Bids made by Existing Shareholders both under Existing Shareholders Reservation Portion as well as in the Net Issue shall not be treated as multiple Bids.

Our Company reserve the right to reject, in our absolute discretion, all or any multiple Bids in any or all categories.

### **‘PAN’ or ‘GIR’ Number**

Where Bid(s) is/ are for Rs. 50,000 or more, the Bidder or in the case of a Bid in joint names, each of the Bidders, should mention his/ her PAN allotted under the I.T. Act. **The copy of the PAN card (s) or PAN allotment letter(s) is required to be submitted with the bid-cum-application form.** Applications without this information and documents will be considered incomplete and are liable to be rejected. **It is to be specifically noted that Bidders should not submit the GIR number instead of the PAN, as the Bid is liable to be rejected on this ground.** In case the sole/ First Bidder and joint Bidder(s) is/ are not required to obtain PAN, each of the Bidder(s) shall mention “Not Applicable” and in the event that the sole Bidder and/ or the joint Bidder(s) have applied for PAN which has not yet been allotted each of the Bidder(s) should mention “Applied for” in the Bid cum Application Form. Further, where the Bidder(s) has mentioned “Applied for” or “Not Applicable”, the sole/ First Bidder and each of the joint Bidder(s), as the case may be, would be required to submit Form 60 (form of declaration to be filed by a person who does not have a permanent account number and who enters into any transaction specified in Rule 114B of the Income Tax Rules, 1962), or, Form 61 (form of declaration to be filed by a person who has agricultural income and is not in receipt of any other income chargeable to income-tax in respect of transactions specified in Rule 114B of the Income Tax Rules, 1962), as may be applicable, duly filled along with a copy of any one of the following documents in support of the address: (a) ration card (b) passport (c) driving licence (d) identity card issued by any institution (e) copy of the electricity bill or telephone bill showing residential address (f) any document or communication issued by any authority of the Central Government, state government or local bodies showing residential address (g) any other documentary evidence in support of address given in the declaration. **It may be noted that Form 60 and Form 61 have been amended by a notification issued on December 1, 2004 by the Central Board of Direct Taxes, Department of Revenue, Ministry of Finance. All Bidders are requested to furnish, where applicable, the revised Form 60 or Form 61 as may be applicable.**

### **Unique Identification Number (“UIN”)**

With effect from July 1, 2005, SEBI has decided to suspend all fresh registrations for obtaining Unique Identification Number (UIN) and the requirement to contain/ quote UIN under the SEBI (Central Database of Market Participants) Regulations, 2003 and circular issued in connection thereto by its circular bearing number MAPIN/Cir-13/2005.

### **Right to reject Bids**

In case of QIB Bidders, the Company, in consultation with the BRLMs may reject a bid placed by a qualified QIB for reasons to be recorded in writing, provided that such rejection shall be made at the time of acceptance of the Bid and the reasons therefore shall be disclosed to the QIB Bidders. In case of QIB Bidders, Non-Institutional Bidders and Retail Individual Bidders, we have a right to reject Bids based on technical grounds. Consequent refunds shall be made by cheque or pay order or draft and will be sent to the Bidder’s address at the Bidder’s risk.

### **Grounds for technical rejections**

Bidders are advised to note that Bids are liable to be rejected on, *inter alia*, the following technical grounds:

1. Amount paid does not tally with the amount payable for the highest value of Equity Shares bid for;
2. Age of first Bidder not given;
3. In case of partnership firms, Equity Shares may be registered in the names of the individual partners and no such partnership firm, shall be entitled to apply;
4. Bids by minors;
5. PAN not stated if Bid is for Rs. 50,000 or more and GIR number furnished instead of PAN;
6. Bids for lower number of Equity Shares than specified for that category of investors;
7. Bids at a price less than lower end of the Price Band;

8. Bids at a price more than the higher end of the Price Band;
9. Bids at Cut-Off by Employees bidding for an amount above Rs. 1,00,000, Non-Institutional Bidders and QIB Bidders;
10. Bids for number of Equity Shares, which are not in multiples of 150 Equity Shares;
11. Category not ticked;
12. Multiple Bids as defined in this Prospectus;
13. In case of Bid under power of attorney or by limited companies, corporate, trust etc., relevant documents are not submitted;
14. Bids accompanied by stockinvest/money order/postal order/cash;
15. Signature of sole and/or joint Bidders missing;
16. Bid cum Application Form does not have the stamp of the BRLMs or the Syndicate Members;
17. Bid cum Application Form does not have the Bidder's depository account details;
18. Bid cum Application Form is not delivered by the Bidder within the time prescribed as per the Bid cum Application Form, Bid /Issue Opening Date advertisement and this Prospectus and as per the instructions in this Prospectus and the Bid cum Application Form;
19. In case no corresponding record is available with the Depositories that matches three parameters namely, names of the Bidders (including the order of names of joint holders), the depository participant's identity (DP ID) and the beneficiary account number;
  - (a) Bids for amounts greater than the maximum permissible amounts prescribed by the regulations. See the details regarding the same in the section titled "Issue Procedure – Bids at Different Price Levels" beginning on page 225;
  - (b) Bids by QIBs not submitted through the BRLMs, Co-BRLM or Syndicate Members.
20. Bids by OCBs;
21. Bids by persons resident in United States;
22. Bids by Employees or Directors of the Company not eligible to apply in the Employee Reservation Portion.

#### **Equity Shares in dematerialised form with NSDL or CDSL**

As per the provisions of Section 68B of the Companies Act, the Equity Shares in this Issue shall be allotted only in a dematerialized form, (i.e. not in the form of physical certificates but be fungible and be represented by the statement issued through the electronic mode). Bids from any Bidder without relevant details of his or her depository account are liable to be rejected.

In this context, two agreements have been signed among our Company, the respective Depositories and the Registrar to the Issue:

1. An agreement dated February 20, 2006 between NSDL, us and Registrar to the Issue;
2. An agreement dated February 21, 2006 between CDSL, us and Registrar to the Issue.
  - (a) A Bidder applying for Equity Shares must have at least one beneficiary account with the Depository Participants of either NSDL or CDSL prior to making the Bid.
  - (b) The Bidder must necessarily fill in the details (including the beneficiary account number and Depository Participant's identification number) appearing in the Bid cum Application Form or Revision Form.
  - (c) Equity Shares allotted to a successful Bidder will be credited in electronic form directly to the beneficiary account (with the Depository Participant) of the Bidder.
  - (d) Names in the Bid cum Application Form or Revision Form should be identical to those appearing in the account details with the Depository. In case of joint holders, the names should necessarily be in the same sequence as they appear in the account details with the Depository.
  - (e) If incomplete or incorrect details are given under the heading 'Bidders Depository Account Details' in the Bid cum Application Form or Revision Form, it is liable to be rejected.
  - (f) The Bidder is responsible for the correctness of his or her demographic details given in the Bid cum Application Form vis-à-vis those with his or her Depository Participant.

- (g) It may be noted that Equity Shares in electronic form can be traded only on the stock exchanges having electronic connectivity with NSDL and CDSL. All the Stock Exchanges where our Equity Shares are proposed to be listed have electronic connectivity with CDSL and NSDL.
- (h) The trading of the Equity Shares would be in dematerialised form only for all investors in the demat segment of the respective Stock Exchanges.
- (i) Shareholders will have the option to hold the shares in physical form also.

## COMMUNICATIONS

All future communication in connection with Bids made in this Issue should be addressed to the Registrar to the Issue quoting the full name of the sole or First Bidder, Bid cum Application Form number, details of Depository Participant, number of Equity Shares applied for, date of Bid cum Application Form, name and address of the member of the Syndicate where the Bid was submitted and cheque or draft number and issuing bank thereof.

## PRE-ISSUE AND POST ISSUE RELATED PROBLEMS

We have appointed Mr. Sougata Sengupta, as the Compliance Officer and he may be contacted in case of any pre-Issue or post- Issue-related problems. He can be contacted at the following address:

**Mr. Sougata Sengupta**  
**Company Secretary**  
**Adhunik Metaliks Ltd**  
**2/1A Sarat Bose Road**  
**Kolkata 700 020**

Tel: +91 33 2289 0279-84

Fax: +91 33 2289 0285

E-mail: [ssengupta@adhunikgroup.com](mailto:ssengupta@adhunikgroup.com)

## IMPERSONATION

**Attention of the applicants is specifically drawn to the provisions of sub-section (1) of Section 68 A of the Companies Act, which is reproduced below:**

**“Any person who:**

**(a) makes in a fictitious name, an application to a company for acquiring or subscribing for, any shares therein, or**

**(b) otherwise induces a company to allot, or register any transfer of shares therein to him, or any other person in a**

**fictitious name,**

**shall be punishable with imprisonment for a term which may extend to five years.”**

## Basis of Allocation

A. For Retail Individual Bidders:

1. Bids received from the Retail Individual Bidders at or above the Issue Price shall be grouped together to determine the total demand under this category. The Allotment to all successful Retail Individual Bidders will be made at the Issue Price.
2. The Net Issue size less allocation to Non-Institutional Bidders and QIB Bidders shall be available for allocation to Retail Individual Bidders who have bid in the Issue at a price that is equal to or greater than the Issue Price.
3. If the valid Bids in this category is for less than or equal to 8,986,486 Equity Shares at or above the Issue Price, full allotment shall be made to the Retail Individual Bidders to the extent of their valid Bids.

4. If the valid Bids in this category is greater than 89,86,486 Equity Shares at or above the Issue Price, the allocation shall be made on a proportionate basis up to a minimum of 150 Equity Shares and in multiples of 150 Equity Shares thereafter. For the method of proportionate basis of allocation, refer below.

B. For Non-Institutional Bidders:

1. Bids received from Non-Institutional Bidders at or above the Issue Price shall be grouped together to determine the total demand under this category. The Allotment to all successful Non-Institutional Bidders will be made at the Issue Price.
2. The Net Issue size less allocation to QIB Bidders and Retail Individual Bidders shall be available for allocation to Non-Institutional Bidders who have bid in the Issue at a price that is equal to or greater than the Issue Price.
3. If the valid Bids in this category is less than or equal to 38,51,351 Equity Shares at or above the Issue Price, full allotment shall be made to Non-Institutional Bidders to the extent of their valid Bids.
4. In case the aggregate valid Bids in this category is greater than 38,51,351 Equity Shares at or above the Issue Price, allocation shall be made on a proportionate basis up to a minimum of 150 Equity Shares and in multiples of 150 Equity Shares thereafter. For the method of proportionate basis of allocation refer below.

C. For QIBs:

1. Bids received from the QIB Bidders at or above the Issue Price shall be grouped together to determine the total demand under this category. The Allotment to all the QIB Bidders will be made at the Issue Price.
2. The Net Issue size less allocation to Non-Institutional Portion and Retail Portion shall be available for proportionate allocation to QIB Bidders who have bid in the Issue at a price that is equal to or greater than the Issue Price.
3. However, eligible Bids by Mutual Funds only shall first be considered for allocation proportionately in the Mutual Fund Portion. After completing proportionate allocation to Mutual Funds for an amount of up to 641,892 Equity Shares (the Mutual Fund Portion), the remaining demand by Mutual Funds, if any, shall then be considered for allocation proportionately, together with Bids by other QIBs, in the remainder of the QIB Portion (i.e. after excluding the Mutual Fund Portion). For the method of allocation in the QIB Portion please see the paragraph titled "Illustration of Allotment to QIBs" appearing below. If the valid Bids by Mutual Funds is less than 641,892 Equity Shares, the balance Equity Shares available for allocation in the Mutual Fund Portion will first be added to the QIB Portion and allocated proportionately to the QIB Bidders. For the purposes of this paragraph it has been assumed that the QIB Portion for the purposes of the Issue amounts to at least 50% of the Net Issue size, i.e. 2,56,75,676 Equity Shares.
4. Allotment shall be undertaken in the following manner:
  - (a) In the first instance allocation to Mutual Funds for 5% of the QIB Portion shall be determined as follows:
    - (i) In the event that Mutual Fund Bids exceeds 5% of the QIB Portion, allocation to Mutual Funds shall be done on a proportionate basis for up to 5% of the QIB Portion.
    - (ii) In the event that the aggregate demand from Mutual Funds is less than 5% of the QIB Portion then all Mutual Funds shall get full allotment to the extent of valid Bids received above the Issue Price.
    - (iii) Equity Shares remaining un subscribed, if any, not allocated to Mutual Funds shall be available to all QIB Bidders as set out in (b) below.

- (b) In the second instance allocation to all QIBs shall be determined as follows:
- (i) In the event of over subscription in the QIB Portion, all QIB Bidders who have submitted Bids above the Issue Price shall be allotted Equity Shares on a proportionate basis for up to 95% of the QIB Portion.
  - (ii) Mutual Funds, who have received allocation as per (a) above, for less than the number of Equity Shares Bid for by them, are eligible to receive Equity Shares on a proportionate basis along with other QIB Bidders.
  - (iii) Under-subscription below 5% of the QIB Portion, if any, from Mutual Funds, would be included for allocation to the remaining QIB Bidders on a proportionate basis.
5. Except for any shares allocated to QIB Bidders due to undersubscription in the Retail Portion and/or Non Institutional Portion, the aggregate allocation to QIB Bidders shall be made on a proportionate basis up to a maximum of 1,28,37,838 Equity Shares. For the method of proportionate basis of allocation refer below.

**D. For Employees:**

1. Bids received from the Employees at or above the Issue Price shall be grouped together to determine the total demand under this category. The allocation to all the successful Employees will be made at the Issue Price.
2. If the aggregate demand in this category is less than or equal to 13,51,351 Equity Shares at or above the Issue Price, full allocation shall be made to the Employees to the extent of their demand.
3. If the aggregate demand in this category is greater than 13,51,351 Equity Shares at or above the Issue Price, the allocation shall be made on a proportionate basis up to a minimum of 150 Equity Shares and in multiples of 150 Equity Shares thereafter. For the method of proportionate basis of allocation, refer below.
4. Only Employees may apply under the Employee Reservation Portion.

**Method of Proportionate basis of allocation in the Issue**

Bidders will be categorized according to the number of Equity Shares applied for by them.

1. The total number of Equity Shares to be allotted to each category as a whole shall be arrived at on a proportionate basis, which is the total number of Equity Shares applied for in that category (number of Bidders in the category multiplied by the number of Equity Shares applied for) multiplied by the inverse of the over-subscription ratio.
2. Number of Equity Shares to be allotted to the successful Bidders will be arrived at on a proportionate basis, which is total number of Equity Shares applied for by each Bidder in that category multiplied by the inverse of the over subscription ratio.

In all Bids where the proportionate allotment is less than 150 Equity Shares per Bidder, the allotment shall be made as follows:

1. Each successful Bidder shall be allotted a minimum of 150 Equity Shares; and
2. The successful Bidders out of the total Bidders for a category shall be determined by draw of lots in a manner such that the total number of Equity Shares allotted in that category is equal to the number of Equity Shares calculated in accordance with (b) above; and
3. If the proportionate allotment to a Bidder is a number that is more than 150 but is not a multiple of one (which is the market lot), the decimal would be rounded off to the higher whole number if that decimal is 0.5 or higher. If that number is lower than 0.5, it would be rounded off to the lower whole number. All Bidders in such categories would be allotted Equity Shares arrived at after such rounding off.

If the Equity Shares available for allocation on a proportionate basis to any category are more than the Equity Shares allotted to the Bidders in that category, the remaining Equity Shares available for allotment

shall be first adjusted against any other category, where the allotted Equity Shares are not sufficient for proportionate allotment to the successful Bidders in that category. The balance Equity Shares, if any, remaining after such adjustment will be added to the category comprising Bidders applying for minimum number of Equity Shares.

In case of oversubscription in any of the categories, drawal of lots to finalise the basis of allotment shall be done in the presence of a public representative on the Governing Board of the Designated Stock Exchange. The basis of allotment shall be signed as correct by the Executive Director/ Managing Director fo the Designated Stock Exchaneg and the public representative in addition to the BRLM responsible for the post issue activities and the Registrar to the Issue.

### Illustration of Allotment to QIBs and Mutual Funds (“MF”)

#### A. ISSUE DETAILS

Sr. No.	Particulars	Issue details
1	Issue size	200 million Equity Shares
2	Allocation to QIB (50% of the Net Issue) Of which :	100 million Equity Shares
	a. Reservation for Mutual Funds (5%)	5 million Equity Shares
	b. Balance for all QIBs including Mutual Funds	95 million Equity Shares
3	Number of QIB applicants Number of Equity Shares applied for	10
4	Number of Equity Shares applied for	500 million Equity Shares

#### B. DETAILS OF QIB BIDS

Sr. No.	Particulars	Issue details
1	A1	50
2	A2	20
3	A3	130
4	A4	50
5	A5	50
6	MF1	40
7	MF2	40
8	MF3	80
9	MF4	20
10	MF5	20
	<b>TOTAL</b>	<b>500</b>

# A1-A5: (QIB Bidders other than Mutual Funds), MF1-MF5 (QIB Bidders which are Mutual Funds)

#### C. Details of Allotment to QIB Bidders/Applicants

(Number of equity shares in million)

Type of QIB bidders	Share bid for (in million)	Allocation of 5 million Equity Shares to MF proportionately (please see note 2 below)	Allocation of balance 95 million Equity Shares to QIBs proportionately (please see note 4 below)	Aggregate allocation to MFs

(I)	(II)	(III)	(IV)	(V)
A1	50	0	9.60	0
A2	20	0	3.84	0
A3	130	0	24.95	0
A4	50	0	9.60	0
A5	50	0	9.60	0
MF1	40	1	7.48	8.48
MF2	40	1	7.48	8.48
MF3	80	2	14.97	16.97
MF4	20	0.5	3.74	4.24
MF5	20	0.5	3.74	4.24
	<b>500</b>	<b>5</b>	<b>95</b>	<b>42.42</b>

Please note:

1. The illustration presumes compliance with the requirements specified in this Prospectus in the section titled “Issue Structure” beginning on page 225.
2. Out of 100 million Equity Shares allocated to QIBs, 5 million (i.e. 5%) will be allocated on proportionate basis among five Mutual Fund applicants who applied for 200 shares in the QIB Portion.
3. The balance 95 million Equity Shares [i.e. 100 - 5 (available for Mutual Funds only)] will be allocated on proportionate basis among 10 QIB Bidders who applied for 500 Equity Shares (including 5 Mutual Fund applicants who applied for 200 Equity Shares).
4. The figures in the fourth column titled “Allocation of balance 95 million Equity Shares to QIBs proportionately” in the above illustration are arrived as under :
  - (a) For QIBs other than Mutual Funds (A1 to A5)= Number of Equity Shares Bid for X 95 / 495
  - (b) For Mutual Funds (MF1 to MF5)= [(No. of shares bid for (i.e in column II of the table above) less Equity Shares allotted ( i.e., column III of the table above)] X 95/495
  - (c) The numerator and denominator for arriving at allocation of 95 million Equity Shares to the 10 QIBs are reduced by 5 million shares, which have already been allotted to Mutual Funds in the manner specified in column III of the table above.

#### **DISPOSAL OF APPLICATIONS AND APPLICATION MONEYS**

We shall ensure dispatch of allotment advice, refund orders and give benefit to the beneficiary account with Depository Participants and submit the documents pertaining to the allotment to the Stock Exchanges within 2 (two) working days of date of Allotment. We shall dispatch refund orders, if any, of value up to Rs. 1,500, “Under Certificate of Posting”, and shall dispatch refund orders above Rs. 1,500, if any, by registered post or speed post at the sole or First Bidder’s sole risk and adequate funds for this purpose shall be made available to the Registrar by us.

We shall use best efforts to ensure that all steps for completion of the necessary formalities for listing and commencement of trading at all the Stock Exchanges where the Equity Shares are proposed to be listed, are taken within 7 (seven) working days of finalisation of the basis of allotment.

In accordance with the Companies Act, the requirements of the Stock Exchanges and the SEBI Guidelines we further undertake that:

1. allotment of Equity Shares shall be made only in dematerialised form within 15 (fifteen) days of the Bid /Issue Closing Date;
2. dispatch of refund orders within 15 (fifteen) days of the Bid /Issue Closing Date would be ensured; and
3. we shall pay interest at 15% (fifteen) per annum (for any delay beyond the 15 (fifteen)-day time period as mentioned above), if Allotment is not made and refund orders are not dispatched and/or demat credits are not made to investors within the 15 (fifteen)-day time prescribed above as per

the guidelines issued by the Government of India, Ministry of Finance pursuant to their letter No. F/8/S/79 dated July 31, 1983, as amended by their letter No. F/14/SE/85 dated September 27, 1985, addressed to the stock exchanges, and as further modified by SEBI's Clarification XXI dated October 27, 1997, with respect to the SEBI Guidelines.

4. The Promoter's Contribution in full shall be brought in advance before the Bid/Issue Opening Date.

Refunds will be made by cheques, pay orders or demand drafts drawn on the Escrow Collection Banks and payable at par at places where Bids are received. Bank charges, if any, for cashing such cheques, pay orders or demand drafts at other centers will be payable by the Bidders.

### **Undertaking by our Company**

We undertake as follows:

1. that the complaints received in respect of this Issue shall be attended to by us expeditiously and satisfactorily;
2. that all steps will be taken for the completion of the necessary formalities for listing and commencement of trading at all the stock exchanges where the Equity Shares are proposed to be listed within seven working days of finalisation of the basis of allotment;
3. that the funds required for dispatch of refund orders or allotment advice by registered post or speed post shall be made available to the Registrar to the Issue by us;
4. that the refund orders or allotment advice to the NRIs or FIIs shall be dispatched within specified time; and
5. that no further issue of Equity Shares shall be made till the Equity Shares offered through this Prospectus are listed or until the Bid monies are refunded on account of non-listing, under-subscription etc.
6. that all necessary licenses/registrations/permissions required for the project will be obtained by us.
7. that all the approvals and renewals as mentioned in this PROSPECTUS on page no.199 are in place.

### **Utilisation of Issue proceeds**

Our Board of Directors certify that:

1. all monies received out of the Issue shall be credited/transferred to a separate bank account other than the bank account referred to in sub-section (3) of Section 73 of the Companies Act;
2. details of all monies utilised out of Issue referred above shall be disclosed under an appropriate head in our balance sheet indicating the purpose for which such monies have been utilised;
3. details of all unutilised monies out of the Issue, if any shall be disclosed under the appropriate head in our balance sheet indicating the form in which such unutilised monies have been invested;
4. we shall not have recourse to the Issue proceeds until the approval for trading of the Equity Shares from all the Stock Exchanges where listing is sought has been received.

### **RESTRICTIONS ON FOREIGN OWNERSHIP OF INDIAN SECURITIES**

Foreign investment in Indian securities is regulated through the Industrial Policy of the Government of India notified through press notes and press releases issued from time to time and the FEMA and circulars and notifications issued thereunder. While the policy of the Government prescribes the limits and the conditions subject to which foreign investment can be made in different sectors of the Indian economy, FEMA regulates the precise manner in which such investment may be made. Under the Industrial Policy of the Government, unless specifically restricted, foreign investment is freely permitted in all sectors of Indian economy up to any extent and without any prior approvals, but the foreign investor is required to follow certain prescribed procedures and reporting requirements for making such investment. **As per current**

**foreign investment policies, foreign direct investment in the steel sector is allowed upto 100% under the automatic route.**

By way of Circular No. 53 dated December 17, 2003, the RBI has permitted FIIs to subscribe to shares of an Indian company in a public offer without prior RBI approval, so long as the price of equity shares to be issued is not less than the price at which equity shares are issued to residents. In our Company, as of date the aggregate FII holding cannot exceed 24% of the total issued share capital.

**Subscription by NRIs/ FIIs**

It is to be distinctly understood that there is no reservation for Non-Residents, NRIs and FIIs and all Non-Residents, NRI and FIIs applicants will be treated on the same basis as other categories for the purpose of allocation.

As per the RBI regulations, OCBs cannot participate in this Issue.

The Equity Shares have not been and will not be registered under the Securities Act or any state securities laws in the United States and may not be offered or sold within the United States or to, or for the account or benefit of, "U.S. persons" (as defined in Regulation S under the Securities Act), except pursuant to an exemption from, or in a transaction not subject to, the registration requirements of the Securities Act. Accordingly, the Equity Shares are only being offered and sold outside the United States to certain persons in offshore transactions in compliance with Regulation S under the Securities Act and the applicable laws of the jurisdiction where those offers and sales occur.

As per the current regulations, the following restrictions are applicable for investments by FIIs:

No single FII can hold more than 10% of the post-issue paid-up capital of our Company (i.e., 10% of 9,12,31,247 Equity Shares). In respect of an FII investing in our Equity Shares on behalf of its sub-accounts, the investment on behalf of each sub-account shall not exceed 10% of our total issued capital or 5% of total issued capital of our Company in case such sub account is a foreign corporate or an individual.

As of now, the aggregate FII holding in our Company cannot exceed 24% of the total issued capital of our Company. With approval of our Board and that of the shareholders by way of a special resolution, the aggregate FII holding limit can be enhanced up to 100%; however till date no such resolution has been recommended to our shareholders for approval.

The above information is given for the benefit of the Bidders. Our Company and the BRLMs are not liable for any amendments or modification or changes in applicable laws or regulations, which may happen after the date of this Prospectus. Bidders are advised to make their independent investigations and ensure that the number of Equity Shares bid for do not exceed the applicable limits under laws or regulations.

## MAIN PROVISIONS OF THE ARTICLES OF ASSOCIATION OF OUR COMPANY

Pursuant to Schedule II of the Companies Act, 1956 and the SEBI Guidelines , the main provisions of the Articles of Association *inter alia* relating to alteration of capital, voting rights, dividend, lien, forfeiture, restrictions on transfer and transmission of Equity Shares or debentures and /or on their consolidation/ splitting are detailed hereinbelow.

Please note that each provisions detailed hereinbelow is numbered as per the corresponding article number in the Articles of Association and that capitalised terms used in this section have the meaning that has been given to such terms in the Articles of Association.

### CAPITAL AND INCREASE AND REDUCTION OF CAPITAL

3. The authorised share capital of the Company shall be the capital as specified in clause V of the Memorandum. The Board shall have the power to increase and reduce the share capital of the Company and to divide the shares in the Capital for the time being into several classes as permissible in law and to attach thereto respectively such preferential, deferred, qualified or special rights, privileges or conditions as may be determined by or in accordance with the Articles of Association of the Company to vary, modify, amalgamate or abrogate any such rights, privileges or conditions in such manner as may for the time being be provided in the Articles of Association.
4. The Company in a General Meeting may, from time to time, increase the Capital by the creation of new Shares. Such increase to be of such aggregate amount and to be divided into such Shares of such respective amounts as the resolution shall prescribe. Subject to the provisions of the Act, any Shares of the original or increased capital shall be issued upon such terms and conditions and with such rights and privileges annexed thereto, as the General Meeting resolving upon the creation thereof, shall direct, and if no direction be given, as the Directors shall determine, and in particular, such Shares may be issued with a preferential or qualified right to dividends, or otherwise and in the distribution of assets of the Company, and with a right of voting at General Meetings of the Company in conformity with the Act. Whenever the Capital of the Company has been increased under the provisions of this article, the Directors shall comply with the provisions of the Act.
5. Except in so far as otherwise provided in the conditions of issue of Shares by these presents, any capital raised by the creation of new Shares shall be considered as part of the existing capital, and shall be subject to provisions herein contained, with reference to the payment of calls and installments, forfeiture, lien, surrender, transfer and transmission, voting and otherwise.
6. Subject to the provisions of the Act and article 7 hereof, the Company shall have the power to issue redeemable preference shares which are or at the option of the Company are liable to be redeemed and the resolution authorising such issue shall prescribe the manner, terms and conditions of redemption.
7. On the issue of redeemable preference shares under the provisions of article 6 hereof, the following provisions shall take effect:
  - 7.1 no such shares shall be redeemed except out of the profits of the Company which would otherwise be available for dividend or out of the proceeds of a fresh issue of shares made for the purpose of the redemption.
  - 7.2 no such shares shall be redeemed unless they are fully paid.

- 7.3 where any such shares are redeemed otherwise than out of the proceeds of a fresh issue, there shall, out of the profits which would otherwise have been available for dividend, be transferred to a reserve fund, to be called the “capital redemption reserve account” a sum equal to the nominal amount of the shares redeemed and the provisions of the Act relating to the reduction of the share capital of the Company shall, except as provided in this article, apply as if the capital redemption reserve account were paid up share capital of the Company.
8. The Company may (subject to the provisions of the Act) from time to time by Special Resolution reduce its capital, any capital redemption reserve account or security premium account in any manner for the time being authorised by law, and in particular, capital may be paid off on the footing that it may be called upon again or otherwise. This article is not to derogate from any power the Company would have if it were omitted.
9. The Company in a General Meeting may from time to time sub-divide or consolidate its Shares, or any of them, and the resolution whereby any Share is sub-divided, may determine that, as between the holders of the Shares resulting from such sub-division, one or more of such Shares shall have some preference or special advantage as regards dividend, capital or otherwise over or as compared with the other or others. Subject as aforesaid, the Company in a General Meeting may also cancel Shares which have not been taken or agreed to be taken by any person and diminish the amount of its share capital by the amount of the Shares so cancelled.
10. Whenever the Capital is divided into different classes of Shares all or any of the rights and privileges attached to each class may, subject to the provisions of the Act, be modified, commuted, affected or abrogated or dealt with by an agreement between the Company and any person purporting to contract on behalf of that class, provided such agreement is ratified in writing by holders of at least three-fourths of nominal value of the issued Shares of the class or is confirmed by a Special Resolution passed at a separate meeting of the holders of Shares of that class and supported by the votes of the holders of at least three-fourths of those Shares, and all the provisions hereinafter contained as to General Meetings shall mutatis mutandis apply to every such meeting, but so that the quorum thereof shall be members present in person or by proxy and holding three-fourths of the nominal amount of the issued Shares of the class. This article is not to derogate from any power the Company would have if it were omitted.

## **SHARES AND CERTIFICATES**

11. The Company shall cause to be kept a register and index of Members and debenture-holders if any. The Company shall be entitled to keep in any State of country outside India a branch register of Members or debenture-holders resident in that State or country called a “foreign register”.
12. The Shares in the Capital shall be numbered progressively according to their several denominations, and except in the manner hereinbefore mentioned, no Share shall be sub-divided. Every forfeited or surrendered Share shall continue to bear the number by which the same was originally distinguished.
13. Further issue of Shares:
- 13.1 Where at the time after the expiry of two years from the formation of the Company or at any time after the expiry of one year from the allotment of Shares in the Company made for the first time after its formation, whichever is earlier, it is proposed to increase the subscribed capital of the Company by allotment of further Shares either out of the unissued capital or out of the increased share capital then:
- 13.1.1 Such further Shares shall be offered to the persons who at the date of the offer, are holders of the equity Shares of the Company, in proportion as near as circumstances admit, to the capital paid up on these Shares at the date;

- 13.1.2 Such offer shall be made by a notice specifying the number of Shares offered and limiting a time not less than fifteen days from the date of the offer and the offer if not accepted, will be deemed to have been declined;
- 13.1.3 The offer aforesaid shall be deemed to include a right exercisable by the person concerned to renounce the Shares offered to them in favour of any other person and the notice referred to them shall contain a statement of this right. Provided that the Directors may decline, without assigning any reason to allot any Shares to any person in whose favour any Member may renounce the Shares offered to him;
- 13.1.4 After expiry of the time specified in the aforesaid notice or on receipt of earlier intimation from the person to whom such notice is giving that he declines to accept the Shares offered, the Board may dispose off such shares in such manner and to such person(s) as they may think, in their sole discretion, fit.
- 13.2 Notwithstanding anything contained in article 13.1 hereof, the further Shares aforesaid may be offered to any person (whether or not those persons include the persons referred to in article 13.1.1 hereof in any manner whatsoever if:-
- 13.2.1 A Special Resolution to that affect is passed by the Company in a General Meeting, or
- 13.2.2 Where no such Special Resolution is passed, if the votes cast (whether on a show of hands or on a poll as the case may be) in favour of the proposal contained in the resolution moved in the General Meeting (including the casting vote, if any, of the chairman) by the Members who, being entitled to do so, vote in person, or where Proxies are allowed, by Proxy, exceed the votes, if any, cast against the proposal by Members, so entitled and voting and the Central Government is satisfied on an application made by the Board of Directors in this behalf that the proposal is most beneficial to the Company.
- 13.3 Nothing in article 13.1.3 hereof shall be deemed:
- 13.3.1 To extend the time within which the offer should be accepted; or
- 13.3.2 To authorise any person to exercise the right of renunciation for a second time on the ground that the person in whose favour the renunciation was first made has declined to take the Shares comprised in the renunciation.
- 13.3.3 Nothing in this article shall apply to the increase of the subscribed capital of the Company caused by the exercise of an option attached to the debenture issued or loans raised by the Company:
- 13.3.4 To convert such debentures or loans into Shares in the Company; or
- 13.3.5 To subscribe for Shares in the Company
- Provided that the terms of issue of such debentures or the terms of such loans include a term providing for such option and such term:
- (a) either has been approved by the Central Government before the issue of the debentures or the raising of the loans or is in conformity with the Public Companies (Terms of issue of debentures and raising of loans with option to convert such debentures or loans to shares) Rules, 1977 or any other rules made by that Government in this behalf; and
- (b) in the case of debentures or loans or other than debentures issued to or loans obtained from Government or any institution specified by the Central Government in this behalf, has also been approved by a Special Resolution passed by the Company in General Meeting before the

issue of the debentures or the raising of the loans.

14. Subject to the provisions of these Articles of Association and of the Act, the Shares shall be under the control of the Directors, who may allot or otherwise dispose of the same or any of them to such persons, in such proportion and on such terms and conditions and either at a premium or at par or (subject to the compliance with the provisions of the Act) at a discount and at such time as they may from time to time think fit and with the sanction of the Company at a General Meeting to give any person or persons the option or right to call for any Shares either at par or premium during such time and for such consideration as the Directors think fit, and may issue and allot Shares in the capital of the Company on payment in full or part of any property sold and transferred or for any services rendered to the Company in the conduct of its business and any Shares which may so be allotted may be issued as fully paid up Shares and if so issued shall be deemed to be fully paid up Shares. Provided that the option or right to call for Shares shall not be given to any person or persons without the sanction of the Company in a General Meeting. The Board of Directors shall cause to be made the return as to allotment pursuant to allotment of any Shares.
15. In addition to and without derogating from the powers for the purpose conferred on the Board under articles 13 and 14, the Company may, at a General Meeting, subject to the provisions of the Act, determine that Shares (whether forming part of the original capital or of any increased capital of the Company) shall be offered to such persons (whether members or not) in such proportion and on such terms and conditions and either (subject to compliance with the provisions of the Act) at a premium or at a discount as such General Meeting shall determine and with full power to give any person (whether a member or not) the option to call for or be allotted Shares of any class of the Company, either at a premium or at par or at a discount as such General Meeting shall determine and with full power to give any person (whether a member or not) the option being exercisable at such times and for such consideration as may be directed by such General Meeting of the Company and the Company at such General Meeting may make any other provisions whatsoever for the issue, allotment or disposal of any Shares.
16. Any application signed by or on behalf of an applicant for Shares of the Company, followed by an allotment of any Share shall be an acceptance of Shares within the meaning of these provisions and every person who, does or otherwise accepts Shares and whose name is on the register of members shall for the purpose of these provisions, be a member.
17. The money (if any) which the Board shall, on the allotment of any Share being made by them which is required or directed to be paid by way of deposit, call or otherwise in respect of any Shares allotted by them shall immediately on the insertion of the name of the allottee in the register of members as the name of the holder of such Shares, become a debt due to and recoverable by the Company from the allottee thereof, and shall be paid by him accordingly,
18. Every member, or his heirs, executors or administrators shall pay to the Company the portion of the capital represented by his Share or Shares which may, for the time being, remain unpaid thereon, in such amounts, at such time or times, and in such manner as the Board shall, from time to time in accordance with the Company's regulations, require or fix for the payment thereof.
19. Every member or allottee of Shares shall be entitled, without payment, to receive one or more certificates in marketable lots, for all the Shares of each class or denomination registered in his name, or if the Directors so approve (upon paying such fee as the Directors may from time to time determine) shall be entitled to several certificates, each for one or more of such Shares and the Company shall complete and have ready for delivery such certificates within three months from the date of allotment, unless the conditions of issue thereof otherwise provide, or within two months of the receipt of application of registration of transfer, transmission, sub-division, consolidation or renewal of any of its shares as the case may be. Every certificate of Shares shall be under the seal of Company and shall specify the number and distinctive numbers of Shares in respect of which it is issued and the amount paid-up thereon and shall be in such form as the Directors may prescribe or approve. Provided that in respect of a share or Shares held jointly by

- several persons, the Company shall not be required to issue more than one certificate and delivery of a certificate of Shares to one of several joint holders shall be sufficient delivery to all such holders. Such certificate shall be issued only in pursuance of a resolution passed by the Board and on surrender to the Company of its letter of allotment or its fractional coupons or requisite value, save in cases of issues against letters of acceptance of renunciation or in cases of issue of bonus Shares. Every such certificate shall be issued under the seal of the Company, which shall be affixed in the presence of two Directors or persons acting on behalf of the Directors with a duly registered power of attorney, and the Secretary or some other person appointed by the Board for the purpose; and two Directors or their attorneys and the Secretary or other person shall sign the share certificate, provided that if the composition of the Board permits, at least one of the aforesaid two Directors shall be a person other than a Managing or Whole-time Director. Particulars of every issue shall be entered in the register of members against the name of the person, to whom it has been issued, indicating the date of issue.
20. Any two or more joint allottees of a Share shall, for the purpose of this article, be treated as a single member, and the certificate of any Share, which may be the subject of joint ownership, may be delivered to the person first named which shall be sufficient delivery to all of them. For any further certificate the Board shall be entitled, but shall not be bound to prescribe a charge not exceeding Rupee one for each certificate.
21. A Director may sign a share certificate by affixing his signature thereon by means of any machine, equipment or other mechanical or electrical means, such as engraving in metal or lithography, but not by means of a rubber stamp, provided that the Director shall be responsible for the safe custody of such machine, equipment or other material used for the purpose.

#### **ISSUE OF NEW CERTIFICATE IN PLACE OF ONE DEFACED, LOST OR DESTROYED**

22. If any certificate be worn out, defaced, mutilated or torn or if there be no further space on the back thereof for endorsement of transfer, then upon production and surrender thereof to the Company, a new certificate may be issued in lieu thereof and if any certificate is lost or destroyed then upon proof thereof to the satisfaction of the Company and on execution of such indemnity as the Company deems adequate, being given, a new certificate in lieu thereof shall be given to the party entitled to such lost or destroyed certificate. Every certificate under this article shall be issued without payment of fees if the Directors so decide, or on payment of such fees (not exceeding Rs. 2 for each certificate) as the Directors shall prescribe. Provided that no fee shall be charged for issue of a new certificates in replacement of those which are old, defaced or worn out or where there is no further space on the back thereof for endorsement or transfer.

Provided that notwithstanding what is stated above the Directors shall comply with such rules, regulations or requirements of any stock exchange or the rules made under the Act or the rules made under the Securities Contracts (Regulation) Act, 1956 or any other Act, or rules applicable in this behalf.

Provided further that:

- (a) No certificate of any Share or Shares shall be issued either in exchange for those which are those sub-divided or consolidated, unless the certificate in lieu of which it is issued is surrendered to the Company.
- (b) If a share certificate is lost or destroyed, a new certificate in lieu thereof shall be issued only with the prior consent of the Board and on such terms, if any, as to evidence and indemnity as to payment of out-of-pocket expenses incurred by the Company in investigating evidence, as the Board may think fit.
- (c) When a new share certificate has been issued in pursuance of this article, it shall state on the face of it and against the stub or counterfoil to the effect that it is a duplicate and issued in lieu of the earlier share certificate and the share certificate number. The word

“duplicate” shall be stamped or punched in bold letters across the face of the share certificate.

- (d) Where a new share certificate has been issued in pursuance of this article, particulars of every such share certificate shall be entered in a register of renewed and duplicate certificate indicating against the names of the persons to whom the certificate is issued, the number and date of issue of the share certificate in lieu of which the new certificate is issued, and the necessary changes be indicated in the register of members by suitable cross reference in the remarks column.
  - (e) All blank forms to be issued for issue of share certificates shall be printed and the printing shall be done only on the authority of a resolution of the Board. The blank forms shall be consecutively machine numbered and the forms and the blocks and engravings relating to the printing of such forms shall be kept in the custody of the Secretary or of such other person as the Board may appoint for the purpose, and the Secretary or the other person as aforesaid shall be responsible for rendering an account of these forms to the Board.
  - (f) The Managing Director of the Company for the time being or, if the Company has no Managing Director, every Director of the Company shall be responsible for the maintenance, preservation and safe custody of all books and documents relating to the issue of share certificates except the blank forms of share certificates referred to in sub-article (e).
  - (g) All books referred to in sub-article (f) shall be preserved in good order and condition on a permanent basis.
23. If any Share stands in the names of two or more persons, the person first named in the register shall, as regards receipt of dividends or bonus or service of notice and all or any other matter connected with the Company, except voting at meetings, be deemed the sole holder thereof, but the joint holders of a Share shall be severally as well as jointly liable for the payment of all installments and calls due in respect of such Shares and for all incidents thereof according to the Company’s regulations.
24. Except as ordered by a Court of competent jurisdiction, or as required by law, the Company shall not be bound to recognize any equitable, contingent, future or partial interest in any Share, or (except provided) any right in respect of a Share other than an absolute right thereto, in accordance with these provisions, the person from time to time registered as the true and legal holder thereof; but the Board shall be at liberty at their sole discretion to register any Share in the joint names of any two or more persons or the survivor or survivors of them.
25. The Company shall have power, subject to and in accordance with all the applicable provisions of the Act and the rules made thereunder, to purchase any of its own fully paid Shares or other specified securities’ whether or not they are redeemable and may make a payment out of its free reserves or securities premium account of the Company or proceeds of any Shares or other specified securities provided that no buy back of any kind of Shares or other specified securities shall be made out of the proceeds of an earlier issue of the same kind of Shares or same kind of other specified securities or from such other sources as may be permitted by Law and on such terms, conditions and in such manner as may be prescribed by the Law from time to time in respect of such purchase.

The provisions of the aforesaid article shall mutatis mutandis apply to Debentures of the Company.

#### **UNDERWRITING AND BROKERAGE**

26. Subject to the provisions of the Act, the Company may at any time pay a commission to any person in consideration of his subscribing or agreeing to subscribe (whether absolutely on conditionally) for any Shares in or debentures of the Company, but so that the commission paid

shall not exceed in the case of Shares, five per cent of the price at which the Shares are issued, and in the case of debentures, two and a half per cent of the price at which the debentures are issued. Such commission may be satisfied by payment of cash or by allotment of fully or partly paid shares or partly in one way and partly in the other.

27. The Company may pay a reasonable sum for brokerage.

#### **B. DEMATERIALISATION OF SECURITIES**

28. The provisions of this article shall apply notwithstanding anything to the contrary contained in any other articles.

29. For the purpose of this article:

‘Beneficial Owner’ means a person or persons whose name is recorded as such with a depository.

‘Depository’ means a company formed and registered under the Companies Act, 1956, and which has been granted a certificate of registration to act as depository under Securities & Exchange Board of India Act, 1992; and wherein the securities of the Company are dealt with in accordance with the provisions of the Depositories Act, 1996.

30. The Company shall be entitled to dematerialize securities and to offer securities in a dematerialized form pursuant to the Depositories Act, 1996.

31. Every holder of or subscriber to securities of the Company shall have the option to receive certificates for such securities or to hold the securities with a Depository. Such a person who is the beneficial owner of the securities can at any time opt out of a depository, if permitted by law, in respect of any securities in the manner provided by the Depositories Act, 1996 and the Company shall, in the manner and within the time prescribed, issue to the beneficial owner the required certificates for the securities. If a person opts to hold his securities with the depository, the Company shall intimate such depository the details of allotment of the securities, and on receipt of the information, the depository shall enter in its record the name of the allottee as the beneficial owner of the securities.

32. All securities held by a depository shall be dematerialized and be in fungible form.

33. Rights of Depositories:

33.1 Notwithstanding anything to the contrary contained in the Act or these presents, a Depository shall be deemed to be the registered owner for the purposes of effecting transfer of ownership of securities of the Company on behalf of the beneficial owner.

33.2 Save as otherwise provided in (a) above, the Depository as the registered owner of the securities shall not have any voting rights or any other rights in respect of the securities held by it.

33.3 Every person holding securities of the Company and whose name is entered as the beneficial owner of securities in the record of the depository shall be entitled to all the rights and benefits and be subject to all the liabilities in respect of the securities which are held by a depository and shall be deemed to be a Member of the Company.

34. Notwithstanding anything contained in the Act or these presents to the contrary, where securities of the Company are held in a Depository, the records of the beneficiary ownership may be served by such Depository on the Company by means of electronic mode or by delivery of floppies or discs.

35. Nothing contained in the Act or these presents with respect to the transfer of Shares/securities of the Company, shall apply to a transfer of securities effected by a transferor and transferee both of whom are entered as beneficial owners in the records of a depository.

36. Notwithstanding anything contained in the Act or these presents, where securities are dealt with by a Depository, the Company shall intimate the details thereof to the Depository immediately on allotment of such securities..
37. Nothing contained in the Act or these presents regarding the necessity of having distinctive numbers for securities issued by the Company shall apply to securities held with a Depository.
38. The register and index of beneficial owners maintained by a Depository under the Depositories Act, 1996 shall be deemed to be the register and index of members and security holders for the purposes of these presents.

#### **INTEREST OUT OF CAPITAL**

39. Where any Shares are issued for the purpose of raising money to defray the expenses of the construction of any work or building, or the provision of any plant, which cannot be made profitable for a lengthy period, the Company may pay interest on so much of that share capital as is for the time being paid up for the period, at the rate and subject to the conditions and restrictions provided by under the provisions of the Act and may charge the same to capital as part of the cost of construction of the work or building, or the provision of plant.

#### **CALLS**

40. The Board may, from time to time and subject to the terms on which any Shares have been issued and subject to the conditions of allotment, by a resolution passed at a meeting of the Board (and not by circular resolution) make such call as it thinks fit upon the Members in respect of all moneys unpaid on the Shares held by them respectively, and each Member shall pay the amount of every call so made on him to the person or persons and at the times and places appointed by the Board. A call may be made payable by installments.
41. Fifteen days notice in writing of any call shall be given by the Company specifying the time and place of payment, and the person or persons to whom such call shall be paid.
42. A call shall be deemed to have been made at the time when the resolution authorizing such call was passed at a meeting of the Board.
43. A call may be revoked or postponed at the discretion of the Board.
44. The option or right to call of Shares not be given to any person except with the sanction of the Company in general meeting.
45. The joint-holders of a Share shall be jointly and severally liable to pay all calls in respect thereof.
46. The Board may, from time to time at its discretion, extend the time fixed for the payment of any call, and may extend such time as to all or any of the members who from residence at a distance or other cause, the Board may deem fairly entitled to such extension, but no member shall be entitled to such extension save as a member of grace and favour.
47. If any member fails to pay any call due from him on the day appointed for payment thereof, or any such extension thereof as aforesaid, he shall be liable to pay interest of the same from the day appointed for the payment thereof to the time of actual payment at such rate as shall from time to time be fixed by the Board, but nothing in this article shall render it obligatory for the Board to demand or recover any interest from any such member.
48. Any sum, which may pursuant to the be the terms of issue of a Share becomes payable on allotment or at any fixed date, whether on account of the nominal value of the Share or by way of premium, shall for the purposes of these presents be deemed to be a call duly made and payable, on the date on which by the terms of issue the same becomes payable and in case of non-payment, all the relevant provisions of these articles as to payment of interest and expenses, forfeiture or

otherwise, shall apply as if such sum had become payable by virtue of a call duly made and notified.

49. On the trial or hearing of any action or suit brought by the Company against any Member or his representatives for the recovery of any money claimed to be due to the Company in respect of his Shares, it shall be sufficient to prove that the name of the member, in respect of whose Shares, the money is sought to be recovered, appears entered on the register of members as the holder, at or subsequently to the date at which the money is sought to be recovered, is alleged to have become due on the Shares in respect of which such money is sought to be recovered; that the resolution making the call is duly recorded in the minutes book; and that notice of such call was duly given to the member or his representatives used in pursuance of these presents and that it shall not be necessary to prove the appointment of the Directors who made such call, nor that a quorum of Directors was present at the Board at which any call was made nor that the meeting at which any call was made duly convened or constituted nor any other matters whatsoever, but the proof of the matter aforesaid shall be conclusive evidence of the debt.
50. Neither the receipt by the Company of a portion of any money which shall from time to time be due from any Member to the Company in respect of his Shares, either by way of principal or interest, nor any indulgence granted by the Company in respect of the payment of any such money, shall preclude the Company from thereafter proceeding to enforce a forfeiture of such shares as hereinafter provided.
- 50.1 The Board may, if it thinks fit, agree to and receive from any Member willing to advance the same, all or any part of the accounts of his respective Shares beyond the sums actually called up; and upon the moneys so paid in advance or upon so much thereof, from time to time and at any time thereafter as exceeds the amount of the calls then made upon and due in respect of the Shares on account of which such advances are made, the Board may pay or allow interest, at such rate not exceeding, unless the Company in a General Meeting shall otherwise direct, six per cent per annum, as may be agreed upon by the Board and the Members paying the sum in advance. The Board may agree to repay at any time any amount so advanced. Provided that Moneys paid in advance of calls on any Shares may carry interest but shall not confer a right to dividend or to participate in profit.
- 50.2 No member paying any such sum in advance shall be entitled to voting rights in respect of the moneys so paid by him until the same would but for such payment become presently payable.
- 50.3 The provision of this article shall mutatis mutandis apply to the calls on Debentures.

#### **LIEN**

51. The Company shall have a first and paramount lien upon all the Shares (other than fully paid-up Shares) registered in the name of each member (whether solely or jointly with others) and upon the proceeds of sale thereof, for all moneys (whether presently payable or not) called or payable at a fixed time in respect of such Shares and no equitable interest in any Shares shall be created except upon the footing, and upon the condition that article 24 hereof is to have full effect. Any such lien shall extend to all dividends and bonuses from time to time declared in respect of such Shares. Unless otherwise agreed, the registration of a transfer of Shares shall operate as a waiver of the Company's lien, if any, on such Shares. The Directors may at any time declare any Shares wholly or in part to be exempt from the provisions of this clause.
52. For the purpose of enforcing such lien, the Board may sell the Shares subject thereto in such manner as they shall think fit, and for that purpose may cause to be issued a duplicate certificate in respect of such Shares and may authorise one of their member to execute a transfer thereof on behalf of and in the name of such Member. No sale shall be made until such period as aforesaid shall have arrived, and until notice in writing of the intention to sell shall have been served on such member or his representatives and default shall have been made by him or them in payment,

fulfillment, or discharge of such debts, liabilities or engagements for fourteen days after such notice.

53. The net proceeds of any such sale shall be received by the Company and applied in or towards payment of such part of the amount in respect of which the lien exists as is presently payable and the residue, if any, shall (subject to a like lien for sums not presently payable as existed upon the Shares before the sale) be paid to the persons entitled to the Shares at the date of the sale.

#### **FORFEITURE OF SHARE**

54. If any Member fails to pay any call or instalment on or before the day appointed for the payment of the same the Board may at any time thereafter during such time as the call or instalment remains unpaid, serve notice on such Member requiring him to pay the same, together with any interest that may have accrued and all expenses that may have been incurred by the Company by reason of such non payment.
55. The notice shall name a day (not being less than fourteen days from the date of the notice) and a place or places on and at which such call or instalment and such interest and expenses as aforesaid are to be paid. The notice shall also state that in the event of non payment at or before the time, and at the place appointed the Shares in respect of which such call was made or installment is payable will be liable to be forfeited.
56. If the requisitions of any such notice as aforesaid be not complied with, any Shares in respect of which such notice has been given may, at any time thereafter, before payment of all calls, or installments, interest and expenses, due in respect thereof, be forfeited by a resolution of the Board to that effect. Such forfeiture shall include all dividends declared in respect of the forfeited Shares and not actually paid before the forfeiture.
57. When any Shares shall have been so forfeited, notice of the forfeiture shall be given to the Member in whose name it stood immediately prior to the forfeiture, and an entry of the forfeiture, with the date thereof, shall forthwith be made in the register of members, but no forfeiture shall be in any manner invalidated, by any omission or neglect to give such notice or to make any such entry as aforesaid.
58. Any Share so forfeited shall be deemed to be the property of the Company, and the Board may sell, re-allot or otherwise dispose of the same in such manner as it may think fit.
59. The Board may, at any time before any Share so forfeited shall have been sold, re-allotted or otherwise disposed of, annul the forfeiture thereof upon such conditions as it thinks fit.
60. A person whose Shares have been forfeited shall cease to be a member in respect of the forfeited Shares, but shall notwithstanding, remain liable to pay, and shall forthwith pay to the Company, all calls, or installment, interest and expenses, owing in respect of such Shares at the time of the forfeiture, together with interest thereon, from the time of forfeiture until payment, at such rate as the Board may determine and the Board may enforce the payment thereof, to any party thereof, without any deduction or allowance for the value of the Shares at the time of forfeiture, but shall not be under any obligation to do so.
61. The forfeiture of a Share involve extinction, at the time of the forfeiture, of all interest and all claims and demands against the Company in respect of the Share and all other rights, incidental to the Share except only such of those rights as by these presents are expressly saved.
62. A duly verified declaration in writing that the declarant is a Director of the Company, and that certain Shares in the Company have been duly forfeited on a date stated in the declaration shall be conclusive evidence of the facts therein stated as against all persons claiming to be entitled to the Shares and such declaration or disposition thereon shall constitute a good title to such Shares; and the person to whom any such Share is sold shall be registered as a Member in respect of such Share and shall not be bound to see to the application of the purchase money, nor shall his title to

such Share be affected by any irregularity or invalidity in the proceedings in reference to such forfeiture, sale or disposition.

63. Upon any sale, re-allotment or other disposal under the provisions of the preceding articles, the certificate or certificates originally issued in respect of the relative Shares shall (unless the same shall on demand by the Company have been previously surrendered to it by the defaulting member) stand cancelled and become null and void and of no effect, and the Directors, shall be entitled to issue a duplicate certificate or certificates in respect of the said Shares to the person or persons, entitled thereto.

#### **TRANSFER AND TRANSMISSION OF SHARES**

64. The Company shall keep a book to be called the 'register of transfers', and therein shall be fairly and directly entered particulars of every transfer or transmission of any Share.
65. A common instrument of transfer shall be used which shall be in writing in case of Shares/Debentures held in physical form and all the provisions pertaining to the transfer of shares under the Act and any statutory modification thereof, shall be duly complied with in respect of all transfer of Shares and the registration thereof.
66. Every such instrument of transfer shall be executed both by transferor and the transferee and the transferor shall be deemed to remain the holder of such Shares until the name of the transferee shall have been entered in the register of members in respect thereof. The Board shall not issue or register a transfer of any Shares in favour of a minor (except in cases when they are fully paid up).
67. The Board shall have power on giving seven days' previous notice by advertisement in some newspaper circulating in the district in which the registered office of the Company is situate, close the transfer books, the register of members or register of debenture holders at such time or times and for such period or periods, not exceeding thirty days at a time and not exceeding in the aggregate forty-five days in each year, as it may deem expedient.
68. Subject to the provisions of the Act the Board may at its own absolute and uncontrolled discretion and by giving reasons, decline to register or acknowledge any transfer of Shares whether fully paid or not and the right of refusal shall not be affected by the circumstances that the proposed transferee is already a Member of the Company, but in such case the Directors shall within two months from the date on which the instrument of transfer was lodged with the Company, send to the transferee and the transferor notice of the refusal to register such transfer provided that registration of a transfer shall not be refused on the ground of the transferor being either alone or jointly with any other person or persons, indebted to the Company on any account whatsoever, except where the Company has lien on Shares. The transfer of Shares or Debentures in whatever lot shall not be refused except in accordance with this article.
69. Every holder of Shares in, or Debentures of the Company may at any time nominate, in the manner prescribed under the Act, a person to whom his Shares in or Debentures of the Company shall vest in the event of death of such holder.

Where the Shares in, or Debentures of the Company are held by more than one person jointly, the joint holders may together nominate, in the prescribed manner, a person to whom all the rights in the Shares or Debentures of the Company, as the case may be, held by them shall vest in the event of death of all joint holders.

Notwithstanding anything contained in any other law for the time being in force or in any disposition, whether testamentary or otherwise, or in these presents, in respect of such Shares in or Debentures of the Company, where a nomination made in the prescribed manner purports to confer on any person the right to vest the Shares in, or Debentures of the Company, the nominee shall, on the death of the Shareholders or holder of Debentures of the Company or, as the case may be, on the death of all the joint holders become entitled to all the rights in the Shares or Debentures of the Company to the exclusion of all other persons, unless the nomination is varied

or cancelled in the prescribed manner under the provisions of the Act.

Where the nominee is a minor, it shall be lawful for the holder of the Shares or holder of Debentures to make the nomination to appoint, in the prescribed manner under the provisions of the Act, any person to become entitled to the Shares in or Debentures of the Company, in the event of his death, during the minority.

70. Any person who becomes a nominee by virtue of the provision of the above article, upon production of such evidence as may be required by the Board and subject as hereinafter provided, elect, either:
- a) to be registered himself as holder of the Shares or Debentures, as the case may be; or
  - b) to make such transfer of the Shares or Debentures, as the case may be, as the deceased shareholder or debenture holder, as the case may be, could have made.

If the nominee, so becoming entitled, elects himself to be registered as holder of the Shares or Debentures, as the case may be, he shall deliver or send to the Company a notice in writing signed by him stating that he so elects and such notice shall be accompanied with death certificate of the deceased shareholder or debenture holder and the certificate(s) of Shares or Debentures, as the case may be, held by the deceased in the Company.

All limitations, restrictions and provisions of the Act relating to the right to transfer and the registration of transfer of shares or debentures and these presents, shall be applicable to any such notice or transfer as aforesaid and the Board may register the relevant Shares or Debentures in the name of the nominee of the transferee as if the death of the registered holder of the Shares or Debentures had not occurred and the notice or transfer were a transfer signed by that shareholder or debenture holder, as the case may be.

A nominee on becoming entitled to Shares or Debentures by reason of the death of the holder, or joint holders shall be entitled to the same dividend and other advantages to which he would be entitled if he were the registered holder of the Share or Debenture, except that he shall not before being registered as holder of such Shares or Debentures, be entitled in respect of them to exercise any right conferred on a member or debenture-holder in relation to meetings of the Company.

The Board may, at any time, give notice requiring any such person to elect either to be registered himself or to transfer the Shares or Debentures, and if the notice is not complied with within ninety days, the Board may thereafter withhold payment of all dividends, bonuses, interest or other moneys payable or rights accrued or accruing in respect of the relevant Shares or Debentures, until the requirements of the notice have been complied with.

71. No Share shall in any circumstances be transferred to any insolvent or persons of unsound mind.
72. Any person becoming entitled to Shares in consequence of the death, lunacy, bankruptcy or insolvency of any Member, or the marriage of a female member, or by any lawful means other than by a transfer in accordance with these presents, may with the consent of the Board of Directors (which it shall not be under any obligation to give) upon producing such evidence that he sustains the character in respect of which he proposes to act under this article as the holder of the Shares or elect to have some person nominated by him and approved by the Board of Directors, be registered as such holder, provided nevertheless, that if such person shall elect to have his nominee registered he shall testify the election by executing to his nominee an instrument of transfer in accordance with the provisions herein contained and until he does so, he shall not be freed from any liability in respect of the Shares.
73. A person entitled to a Share by transmission shall, subject to the right of the Directors to retain such dividends or money as hereinafter provided, be entitled to receive and may give discharge for any dividends or other moneys payable in respect of the Share.

74. Every instrument of transfer shall be presented to the Company duly stamped for registration accompanied by such evidence as the Board of Directors may require, to prove the title of the transferor, his right to transfer the Shares and generally under and subject to such conditions and regulations as the Board of Directors shall from time to time prescribe, and every registered instrument of transfer shall remain in the custody of the Company until destroyed by order of the Board of Directors.
75. For the purpose of the registration of a transfer, the certificate or certificates of the Share or Shares to be transferred must be delivered to the Company along with a properly stamped and executed instrument of transfer.
76. No fee shall be charged for registration of transfer, transmission, probate, succession certificate and letters of administration, certificate of death or marriage, power of attorney or any other similar document.
77. The Company shall incur no liability or responsibility whatsoever in consequence of its registering or giving effect to any transfer of Shares made or purporting to be made by any apparent legal owner thereof (as shown or appearing in the register of members) to the prejudice of persons having or claiming any equitable right, title or interest to or in the said Shares, notwithstanding that the Company may have had notice of such equitable right, title or interest or notice prohibiting registration of such transfer, and may have entered such notice, or deferred thereto, in any book of the Company, and the Company shall not be bound or required to regard or attend or give effect to any notice which may be given to it of any equitable right title or interest, or be under any liability whatsoever for refusing or neglecting so to do, though it may have been entered or referred to in some book of the Company; but the Company shall nevertheless be at liberty to regard and attend to any such notice and give effect thereto, if the Board of Directors shall so think fit.

#### **LISTING OF SECURITIES**

78. Payment of listing fees to the Exchange:

The Company agrees that as soon as its securities are listed on the Exchange, it will pay to the Exchange an initial listing fee as prescribed in the listing agreement entered into by the Company with the Bombay Stock Exchange (“BSE”) and the National Stock Exchange of India Limited (“NSE”), and that thereafter, so long as the securities continue to be listed on the Exchange, it will pay to the Exchange on or before the 30th April, (or such other date as may be prescribed under the applicable laws) in each year an annual listing fee computed on the basis of the capital of the Company as on 31<sup>st</sup> March and worked out as provided in the respective listing agreements with the BSE and NSE. The Company also agrees that it shall pay the additional annual listing fee, at the time of making the application for listing of its securities arising out of further issue, as is computed in terms of the respective listing agreements with the BSE and the NSE for any addition in the capital after 31<sup>st</sup> March.

79. Payment of annual custodial fees to Depositories:

The Company shall pay the Depositories an annual custodial fee at such rates as specified by the SEBI from time to time, failure to pay such fee will attract such penal action by SEBI as it may deem fit.

80. For the purposes of this article the following words shall have the meaning ascribed as hereunder:

“Exchange” means the Bombay Stock Exchange or the National Stock Exchange or any other stock exchange where the securities of the Company may be listed from time to time, as the case may be.

#### **COPIES OF MEMORANDUM AND ARTICLES TO BE SENT TO MEMBERS**

81. Copies of the Memorandum and Articles of Association of the Company and every other

agreement and every resolution referred to in section 192 of the Act shall be sent by the Board to every Member at his request within seven days of the request on payment of Re. 1/- for each copy.

#### **BORROWING POWERS**

82. The Board may, from time to time, at its discretion by means of resolutions passed at meetings of the Board and in compliance with the provisions of the Act, raise or borrow, either from the Directors or from elsewhere and secure the payment of any sum or sums of money for the purpose of the Company; provided that the Board shall not without the sanction of the Company in General Meeting borrow any sum of money which together with money borrowed by the Company (apart from temporary loans obtained from the Company's bankers in the ordinary course of business) exceed the aggregate for the time being of the paid up capital of the Company and its free reserves, that is to say, reserves not set aside for any specific purpose.
83. The Board may raise or secure the repayment of such sum or sums in such manner and upon such terms and conditions in all respects as it thinks fit and in particular, by the issue of bonds, perpetual or redeemable, debentures or debenture stock, or any mortgage, or other security on the undertaking of the whole or any part of the property of the Company both present and future including its uncalled capital for the time being.
84. Any debentures, debenture-stock, bonds other securities may be issued at a discount, premium or otherwise and may be made assignable free from any equities between the Company and the person to whom the same may be issued. Debentures, debenture-stock, bonds or other securities may be issued on the condition that they shall be convertible into Shares of any denomination and with any privileges and conditions as to redemption, surrender, drawing, allotment of Shares, attending (but not voting) at the General Meeting, appointment of Directors or otherwise. Provided that Debentures or loans with a right of conversion into or allotment of Shares shall be issued only with sanction of the Company in General Meeting.
85. No transfer of debentures shall be registered unless a proper instrument of transfer duly stamped and executed by the transferor and transferee has been delivered to the Company together with the certificate or certificates of the debentures. The provisions of transfer of shares under these Articles of Association shall be applicable mutatis mutandis to debentures.
86. If the Board refuses to register the transfer of any debentures, the Company shall, within two months from the date on which the instrument of transfer was lodged with the company, send to the transferee and to the transferor the notice of such refusal.
87. The Board shall cause a proper register to be kept of all mortgages, debentures and charges specifically affecting the property of the Company, and shall cause the requirements of the relevant provisions of the Act pertaining to debenture trust deed, charges and registration thereof in that behalf to be duly complied with, so far as they are ought to be complied with by the Board.
88. The Company shall, if at any time it issues debentures, keep register and index of debenture holders. The Company shall have the power to keep in any State or Country outside India a branch register of debenture-holders, resident in that State or Country.

#### **CONVERSION OF SHARES INTO STOCK AND RECONVERSION**

89. The Company in General Meeting may convert any paid-up Shares into stock and when any Shares shall have been converted into stock, the several holders of such stock may thenceforth transfer their respective interest therein, or any part of such interest, in the same manner and subject to the same regulations as, and subject to which the Shares from which the stock arose might have been transferred, if no such conversion had taken place or as near thereto as circumstances will admit. The Company may at any time re-convert any stock into paid-up Shares of any denomination.

90. The holders of stock shall, according to the amount of stock held by them have the same rights, privileges and advantages as regards dividends and voting at the meetings of the Company, and other matters as if they held the Shares from which the stock arose; but no such privileges or advantages (except participation in the dividends and profits of the Company and in the assets of winding-up) shall be conferred by an amount of stock which would not, if existing in Shares, have conferred that privilege or advantage.

#### **MEETING OF MEMBERS**

91. The Company shall in each year hold a General Meeting as its Annual General Meeting in addition to any other meetings in that year. All General Meetings other than Annual General Meeting shall be Extraordinary General Meetings. The first Annual General Meeting shall be held within eighteen months from the date of incorporation of the Company and the next Annual General Meeting shall be held within six months after the expiry of the financial year in which the first Annual General Meeting was held and thereafter an Annual General Meeting of the Company shall be held within six months after the expiry of each financial year, provided that not more than fifteen months shall elapse between the date of one Annual General Meeting and that of the next. Nothing contained in the foregoing provisions shall be taken as affecting the right conferred upon the Registrar under the provisions of the Act to extend the time within which any Annual General Meeting may be held. Every Annual General Meeting shall be called for during business hours, on a day that is not a public holiday, and shall be held in the office of the Company or at some other place within the city in which the registered office of the Company is situated as the Board may determine and the notices calling the meeting shall specify it as the Annual General Meeting. The Company may in anyone Annual General Meeting fix the time for its subsequent Annual General Meeting. Every Member of the Company shall be entitled to attend either in person or by proxy and the Auditor of the Company shall be entitled to attend and to be heard at any General Meeting which he attends on any part of the business, concerns him as Auditor. At every Annual General Meeting of the Company there shall be laid on the table the Directors' Report (if not already attached in the audited statement of accounts) the proxy register with proxies and the register of directors' share holdings of which the latter register shall remain open and accessible during the continuance of the meeting. The Board shall cause to be prepared the annual list of members, summary of the share capital, balance sheet and profit and loss account and forward the same to the Registrar .
92. The Board may, whenever it thinks fit, call an Extraordinary General Meeting and it shall do so upon a requisition in writing by any member or members holding in the aggregate not less than one-tenth of such of the paid-up capital as at the date carries the right of voting in regard to the matter in respect of which the requisition has been made.
93. Any valid requisition so made by Members must state the objects of the meeting proposed to be called and must be signed by the requisitionists and be deposited at the office provided that such requisition may consist of several documents in file form each signed by one or more requisitionists.
94. Upon the receipt of any such requisition, the Board shall forthwith call an Extraordinary General Meeting, and if they do not proceed within twenty-one days from the date of the requisition being deposited at the office to cause a meeting to be called on a day not later than forty-five days from the date of deposit of the requisition, the requisitionists, or such of their number as represents either a majority in value, of the paid-up share capital of the Company, which ever is less, may themselves call the meeting, but in either case, any meeting so called shall be held within three months from the date of the delivery of the requisition as aforesaid.
95. Any meeting called under the foregoing provisions by the requisitionists shall be called in the same manner, as nearly as possible, as that in which meetings are to be called by the Board.
96. Twenty-one days' notice at least of every General Meeting, Annual or Extraordinary and by whosoever called, specifying the day, place and hour of meeting, and the general nature of the business to be transacted thereat, shall be given in the manner hereinafter provided, to such

- persons as are under these presents entitled to receive notice from the Company. Provided that in the case of an Annual General Meeting with the consent in writing of all the members entitled to vote thereat and in the case of any other meeting, with the consent of members holding not less than 95 percent of such part of the paid up share capital of the Company as gives a right to vote at the meeting, may be convened by a shorter notice. In the case of an Annual General Meeting, if any business other than (i) the consideration of the accounts, balance sheets and reports of the Board of Directors and Auditors (ii) the declaration of dividend, (iii) the appointment of Directors in place of those retiring (iv) the appointment of and fixing of remuneration of the Auditors, is proposed to be transacted then in that event there shall be annexed to the notice of the Meeting a statement setting out all material facts concerning each such item of business including, in particular, the nature of concern or interest, if any, therein of every Director, and the manager (if any). Where any such item of special business relates to or affects any other Company, the extent of shareholding interest in other company of every Director and the manager, if any, of the Company shall also be set out in the statement if the extent of such Share holding interest is not less than 20 percent of the paid-up share capital of that other company. Where any item of business consists of the according of approval to any document by the meeting, the time and place where the document can be inspected shall be specified in the statement aforesaid.
97. The accidental omission to give any such notice as aforesaid to any of the Members or the non receipt thereof shall not invalidate the holding of the meeting or any resolution passed at any such meeting.
  98. No General Meeting, AGM or EGM, shall be competent to enter upon discuss or transact any business which has not been mentioned in the notice or notices upon which it was convened.
  99. Five members present in person shall be quorum for a General Meeting.
  100. A body corporate being a member shall be deemed to be personally present if it is represented by such person duly authorized by a resolution of the board of directors of such body corporate to represent it at a Meeting of the Company.
  101. If, at the expiration of half an hour from the time appointed for holding a meeting of the Company, a quorum shall not be present, the meeting, if convened by or upon the requisition of Members shall stand dissolved, but in any other case the meeting shall stand adjourned to the same day in the next week or, if that day is a public holiday, until the next succeeding day which is not a public holiday, at the same time and place, or to such other day and at such other time and place in the city or town in which the registered office of the Company is for the time being situate as the Board may determine and if at such adjourned meeting a quorum is not present at the expiration of half and hour from the time appointed for holding the meeting, the Members present shall be quorum and may transact the business for which the meeting was called.
  102. The Chairman (if any) of the Board shall be entitled to take the chair at every General Meeting, whether Annual or Extraordinary, if there be no such Chairman of the Board, or if at any meeting he shall not be present within fifteen minutes of the time appointed for holding such meeting, or if he shall be unable or unwilling to take the chair, then the Directors present may choose one of their Member to be the Chairman of the meeting. If no Director be present or if all the Directors present decline to take the chair, then the Members present shall elect one of their number to be Chairman.
  103. No business shall be discussed at any General Meeting except the election of a Chairman, while the chair is vacant.
  104. The Chairman with the consent of the Members may adjourn any meeting from time to time and from place to place in the city in which it is held but, no business shall be transacted at any adjourned meeting other than the business, left unfinished at the meeting from which the adjournment took place.

105. At any General Meeting a resolution put to vote at the meeting shall be decided on a show of hands, unless a poll is ordered to be taken before or on the declaration of the result of the voting on any resolution on a show of hands by the Chairman of the Meeting of his own motion, and shall be ordered to be taken by him on a demand made in that behalf by any Member or Members present in person or proxy and holding shares which confer a power to vote on the resolution not being less than one-tenth of the total voting power in respect of the resolution or by any Member or Members present in person or by proxy and holding Shares in the Company being Shares on which an aggregate sum of not less than fifty thousand rupees has been paid-up. A declaration by the Chairman that a resolution has on a show of hands, been carried unanimously, or by a particular majority, or lost, and an entry to that effect in the minutes book of the Company shall be conclusive evidence of the fact, without proof of the number or proportion of the votes recorded in favour of or against the resolution.
106. In the case of an equality of votes, the Chairman shall, both on a show of hands and at a poll (if any), have a casting vote in addition to the vote or votes to which he may be entitled as a member.
107. If a poll is demanded as aforesaid, the same shall, subject to article 105 be taken at such time (not later than forty-eight hours from the time when the demand was made) and such place in the city or town in which the registered office of the Company is for the time being situate and either by open voting or by ballot, as the Chairman shall direct, and either at once or after an interval or adjournment or otherwise, and the result of the poll shall be deemed to be the resolution of the meeting at which the poll was demanded. The demand for a poll may be withdrawn at any time by the person or persons who made the demand.
108. Where a poll is to be taken, the Chairman of the meeting shall appoint two scrutineers to scrutinize the vote given on the poll and to report thereon to him. One of the scrutineers so appointed shall always be a Member (not being an officer or employee of the Company) present at the meeting provided such Member is available and willing to be appointed. The Chairman shall have power at any time before the result of the poll is declared to remove the scrutineer from office and fill vacancies in the office of scrutineer from such removal or from any other cause.
109. Any poll duly demanded on the election of Chairman of a meeting or on any question of adjournment shall be taken at the meeting forthwith.
110. The demand for a poll except on the questions of the election of the Chairman and of an adjournment shall not prevent the continuance of a meeting for the transaction of any business other than the question on which the poll has been demanded.

#### **VOTE OF MEMBERS**

111. No Member shall be entitled to vote either personally or by proxy, at any General Meeting or meeting of a class of shareholders, either upon a show of hands or upon a poll in respect of any Shares registered in his name on which any calls or other sums presently payable by him have not been paid or, in regard to which the Company has, and has exercised any right of lien.
112. Subject to the provisions of these articles and without prejudice to any special privileges or restrictions as to voting for the time being attached to any class of Shares for the time being forming part of the Capital of the Company, every Member not disqualified by the last preceding article shall be entitled to be present, and to speak and vote at such meeting, and on a show of hands every member present in person shall have one vote and upon a poll the voting rights of every Member present in person or by proxy shall be in proportion to his Shares of the paid-up equity share capital of the Company. Provided, however, if any preference shareholder be present at any meeting of the Company, he shall have a right to vote in respect of such preference shares on every resolution placed before the Company at any meeting, if the dividend due on such capital or any part of such dividend remains unpaid as per the provisions of the Act and to vote only on resolutions placed before the meeting which directly affect the rights attached to his preference Shares.

113. On a poll taken at a meeting of the Company a Member entitled to more than one vote, or his proxy or other person entitled to vote for him, as the case may be, need not, if he votes, use all his votes or cast in the same way all the votes he used or may abstain from voting.
114. A Member of unsound mind or in respect of whom an order has been made by any court having jurisdiction in lunacy may vote whether on a show of hands or on a poll, by his committee or other legal guardian and any such committee or guardian may on poll vote by proxy, if any Member be a minor, the vote in respect of his share or Shares shall be by his guardian, or any of his guardians, if more than one, to be selected in case of dispute by the Chairman of the meeting.
115. If there be joint holders of any Shares, anyone of such person may vote at any meeting or may appoint another person (whether a Member or not) as his proxy in respect of such Shares, as if he were solely entitled thereto by the proxy so appointed and shall not have any right to speak at the meeting and, if more than one of such joint holders be present at any meeting then one of the said persons so present whose name stands higher on the register of members shall alone be entitled to speak and to vote in respect of such Shares, but the other or others of the joint-holders shall be entitled to be present at the meeting. Several executors or administrators of a deceased member in whose name Shares stand shall for the purpose of these articles to be deemed joint holders thereof.
116. Subject to the provisions of these presents, votes may be given either personally or by proxy. A body corporate being a member may vote either by a proxy or by a representative duly authorised by a resolution passed by its board of directors, and such representative shall be entitled to exercise the same rights and powers (including the rights to vote by proxy) on behalf of the body corporate which he represents as the body corporate could exercise if it were an individual member.
117. Any person entitled under article 73 to transfer any Shares may vote at any General Meeting in respect thereof in the same manner, as if he were the registered holder of such Shares, provided that forty eight hours at least before the time of holding the meeting or adjourned meeting, as the case may be at which he proposes to vote he shall satisfy the Directors of his right to transfer such Shares and give such indemnity (if any) as the Directors may require or the Directors shall have previously admitted his right to vote at such meeting in respect thereof.
118. Every proxy (whether a member or not) shall be appointed in writing under the hand of the appointer or his attorney, or if such appointer is a corporation under the common seal of such corporation, or be signed by an officer or any attorney duly authorised by it, and any committee or guardian may appoint such proxy. The proxy so appointed shall not have any right to speak at the meeting.
119. An instrument of proxy may appoint a proxy either for the purpose of a particular meeting specified in the instrument and any adjournment thereof or it may appoint for the purpose of every meeting of the Company, or of every meeting to be held before a date specified in the instrument and every adjournment of any such meeting.
120. A member present by proxy shall be entitled to vote only on a poll.
121. The instrument appointing a proxy and the power of attorney or other authority (if any) under which it is signed or a notarially certified copy of that power or authority shall be deposited at the registered office of the Company not later than forty eight hours before the time for holding the meeting at which the person named in the instrument proposes to vote, and in default the instrument of proxy shall not be treated as valid. No instrument appointing a proxy shall be valid after the expiration of twelve months from the date of its execution.
122. Every instrument of proxy whether for a specified meeting or otherwise shall, as nearly as circumstances will admit, be in any of the forms set out in schedule IX of the Act.
123. A vote given in accordance with the terms of an instrument of proxy shall be valid

notwithstanding the previous death or insanity of the principal, or revocation of the proxy of any power of attorney under which such proxy was signed, or the transfer of the Share in respect of which the vote is given, provided that no intimation in writing of the death or insanity, revocation or transfer shall have been received at the registered office of the Company before the Meeting.

124. No objection shall be made to the validity of any vote, except at any meeting or poll at which such vote shall be tendered, and every vote whether given personally or by proxy, not disallowed at such meeting or poll shall be deemed valid for all purposes of such meeting or poll whatsoever.
125. Notwithstanding any thing contained in the foregoing, the Company shall transact such business, as may be specified by the Central Government from time to time, through the means of postal ballot. In case of resolutions to be passed by postal ballot, no meeting need to be held at a specified time and place requiring physical presence of Members to form a quorum. Where a resolution will be passed by postal ballot, the Company shall, in addition to the requirements of giving requisite clear days notice, send to all the members the following:
- i) Draft resolution and relevant explanatory statement clearly explaining the reasons therefore;
  - ii) Postal ballot for giving assent or dissent, in writing by members and
  - iii) Postage prepaid envelope (by Registered Post) for communicating assents or dissents on the postal ballot to the company with a request to the members to send their communications within 30 days from the date of despatch of notice.

The Company shall also follow such procedure, for conducting vote by postal ballot and for ascertaining the assent or dissent, as may be prescribed by the Act and the relevant rules made thereunder.

126. The Chairman of any meeting shall be the sole judge of the validity of every vote tendered at such meeting. The Chairman present at the taking of a poll shall be the sole judge of the validity of every vote tendered at such poll.
127. Minutes of proceedings of General Meetings:
- 127.1 The Company shall cause minutes of all proceedings of every General Meeting to be kept by making within thirty days of the conclusion of every such meeting concerned, entries thereof in books kept for that purpose with their pages consecutively numbered.
  - 127.2 Each page of every such book shall be initialed or signed and the last page of the record of proceedings of such meeting in such books shall be dated and signed by the Chairman of the same meeting within the aforesaid period of thirty days or in the event of the death or liability of that Chairman within that period, by a Director duly authorised by the Board for the purpose.
  - 127.3 In no case the minutes of proceedings of a meeting shall be attached to any such book as aforesaid by pasting or otherwise.
  - 127.4 The minutes of each meeting shall contain a fair and correct summary of the proceedings thereat.
  - 127.5 All appointments of officers made at any meeting aforesaid shall be included in the minutes of the meetings.
  - 127.6 Nothing herein contained shall require or be deemed to require the inclusion in any such minutes of any matter which in the opinion of the Chairman of the meeting:
    - (a) is or could reasonably be regarded, as, defamatory of any person or

- (b) is irrelevant or immaterial to the proceeding, or
- (c) is detrimental to the interest of the Company.

The Chairman of the meeting shall exercise an absolute discretion in regard to the inclusion or non-inclusion of any matter in the minutes on the aforesaid grounds.

- 127.7 Any such minutes shall be evidence of the proceedings recorded therein.
- 127.8 The book containing the minutes of proceedings of General Meetings shall be kept at the registered office of the Company and shall be open during business hours for such periods not being less in the aggregate than two hours in each day as the Directors determine, to the inspection of any member without charge.

## **DIRECTORS**

- 128. Until otherwise determined by a General Meeting of the Company, the number of Directors (excluding Debenture and alternate Directors, (if any) shall not be less than three nor more than twelve.
- 129. The first Directors of the Company were the following:
  - I. Shri Jugal Kishore Agarwal
  - II. Shri Ghanshyam Das Agarwal
  - III. Shri Mahesh Kumar Agarwal
  - IV. Shri Manoj Kumar Agarwal
- 130. If at any time the Company obtains any loan or any assistance in connection there with by way of guarantee or otherwise from any person, firm, body corporate, local authority or public body (hereinafter called “the institution”) or if at any time the Company issues any Shares or Debentures and enters into any contract or arrangement with the institution, whereby the institution subscribes for or underwrites the issue of the Company’s Shares or Debentures or provides any assistance to the Company in any manner and it is a term of the relative loan, assistance, contract or agreement that the institution shall have the right to appoint one or more directors to the Board of the Company, subject to the terms and conditions of such loan, assistance, contract or arrangement, the institution shall be entitled to appoint one or more director or directors, as the case may be, to the Board of the Company and to remove from office any director so appointed and to appoint another in his place or in the place of the director so appointed who resigns or otherwise vacates his office. Any such appointment or removal shall be made in writing and shall be served at the registered office of the Company. The director or directors so appointed shall neither be required to hold any qualification Shares nor be liable to retire by rotation and shall continue in the office for so long as the relative loan, assistance, contract or arrangement, as the case may be, subsists.
- 131. If it is provided by the trust deed, securing or otherwise in connection with any issue of debentures of the Company, that any person or persons shall have power to nominate a director of the Company, then in the case of any and every such issue of debenture, the person or persons having such power may exercise such power from time to time and appoint a director accordingly. Any director so appointed is herein referred to as “Debenture Director”. A Debenture Director may be removed from office at any time by the person or persons in whom for the time being is vested the power under which he was appointed and another director maybe appointed in his place. A Debenture Director shall not be required to hold any qualification Share nor be liable to retire by rotation and shall continue in the office for so long as the debentures are not redeemed.

132. If the Company at any time has a minimum paid up capital of Rupees five crores or such sum as may be prescribed and at least one thousand or more small shareholders, then the Company may, suo motu or upon requisition of not less than one-tenth of the total number of small shareholders, proceed to appoint a nominee from amongst the small shareholders as a Director of the Company. The small shareholders' director shall before his appointment, file his consent, to act as a director, in writing to the Company and the tenure of such appointment shall be three years at a time without retirement by rotation, but shall be eligible for reappointment for another tenure. He shall, however, not be appointed as Managing Director or whole time director under any circumstances and shall be subject to the same disqualifications and shall vacate his office on the same grounds as are applicable to other Directors, in pursuance of these presents and the subject to the provisions of the Act. The Company shall follow such rules as may be prescribed by the Central Government in this behalf.

No small shareholders' director appointed in accordance with the provisions of this article shall hold office at the same time as small shareholders' director in more than two companies.

133. The Board may appoint an alternate director to act for a Director (hereinafter for the purpose of this article called "the Original Director") during his absence for a period of not less than three months from the State in which the meetings of the Board are ordinarily held. An alternate director appointed under this article shall not hold office for a period longer than that permissible to the original director in whose place he has been appointed and shall vacate the office of the original director when he returns to that State. If the terms of office of the original director are determined before he so returns to that State, any provisions in the Act or in these presents for the automatic reappointment of any retiring Director in default of another appointment shall apply to the original director and not to the alternate director.

134. Subject to the provisions of the Act, the Board shall have power at any time and from time to time to appoint any other qualified person to be an additional director, but so that the total number of Directors including the additional director shall not at any time exceed a maximum of 12 directors as fixed under article 128 of these presents. Any such additional director shall hold office only up to the date of the next Annual General Meeting.

135. Until otherwise determined by the Company in General Meeting, a Director shall not be required to hold any Shares in the capital of the Company as his qualification.

136. Without prejudice to the restrictions imposed by the Act, a Director who is required to hold qualification Shares may act as a Director before acquiring such Shares but shall, if he is not already qualified, obtain his qualification, within two months from his appointment as a Director.

137. Subject to the provisions of the Act, the Board shall have power at any time and from time to time to appoint any other qualified person to be a Director to fill a casual vacancy. Any person so appointed shall hold office only up to the date to which the Director in whose place he is appointed would have held office if it had not been vacated by him.

138. Subject to the provisions of the Act, a Managing Director or Director(s) who is/are in the whole-time employment of the Company may be paid remuneration either by way of a monthly payment or at a specified percentage of the net profits of the Company or partly by one way and partly by the other.

139. Subject to the provisions of the Act, a Director who is neither in the whole-time employment nor a Managing Director, may be paid remuneration either:

- (i) by way of monthly, quarterly or annual payment with the approval of the Central Government, or
- (ii) by way of commission if the Company by a Special Resolution authorized such payment.

140. The fees payable to a Director (including a Managing or whole-time Director, if any), for attending a meeting of the Board or committee thereof may be in accordance with the provisions of the Act of such amount as the Company in General Meeting may from time-to time determine.
141. The Board may allow any pay to any Director who is not a bonafide resident of the place where the meetings of the Board are ordinarily held and who shall come to such place for the purpose of attending any meeting, such sum as the Board may consider fair compensation for traveling, boarding, lodging and other expenses, in addition to his fee for attending such meeting as above specified; and if any Director be called upon to go or reside out of the ordinary place of his residence on the Company's business, he shall be entitled to be repaid and reimbursed any traveling or other expenses incurred in connection with the business of the Company.
142. The continuing Directors may act notwithstanding any vacancy in their body but if, and so long as their number is reduced below the minimum number fixed by the article 128 hereof, the continuing Directors not being less than three, may act for the purpose of increasing the number of directors to that number or for summoning a General Meeting but for no other purpose.
143. The office of a Director shall ipso facto be vacated if:
- (a) he fails to obtain within two months after appointment as director , or at any time thereafter ceases to hold, the Share qualification, if any, necessary for his appointment; or
  - (b) he is found to be unsound mind by a court of competent jurisdiction; or
  - (c) he has applied to be adjudicated as an insolvent and his application is pending;
  - (d) he is adjudged insolvent; or
  - (e) he is convicted by a court in India of any offence involving moral turpitude and is sentenced in respect thereof to imprisonment for not less than six months; or
  - (f) he fails to pay any call in respect of Shares of the Company held by him, whether alone or jointly with others, within six months from the last date fixed for the payment of the call; or
  - (g) he absents from three consecutive meetings of the Board or from all meetings of the Board for a continuous period of three months, whichever is the longer, without obtaining leave of absence from the Board; or
  - (h) he whether by himself or by any person for his benefit or on his account, or any firm of which he is a partner or any private company of which he is a director, accepts a loan, or any guarantee or security for a loan, from the Company in contravention of the provisions of the Act; or
  - (i) he acts in contravention of any of the provisions of the Act; or
  - (j) he has been disqualified by an order of a court of competent jurisdiction under the provisions of the Act; or
  - (k) by notice in writing to the Company that he resigns his office; or
  - (l) any office or place of profit under the Company or under any subsidiary of the Company is held in contravention of section 314 of the Act and by operation of that section he is deemed to vacate the office.
144. Notwithstanding any matter or thing in articles 143.1 (d), (e) and (j) , the disqualification referred to in those sub-clauses shall not take effect:

- (a) for thirty days from the date of adjudication sentence or order; or
  - (b) where an appeal or petition is preferred, within the thirty days aforesaid against the adjudication, sentence or conviction resulting in the sentence, or order until the expiry of seven days from the date on which such appeal or petition is disposed of; or
  - (c) where within the seven days aforesaid any further appeal or petition is preferred in respect of the adjudication, sentence, conviction or order, and the appeal or petition, if allowed, would result in the removal of the disqualification until such further appeal or petition is disposed of.
145. Subject to the provisions of the Act a Director or his relative, a firm in which such Director or relative is a partner, or any other partner in such firm or a private company of which the Director is a member or a private company of which the Company is a member or director, may enter into any contract with Company for the sale, purchase or supply of any goods, materials, or services or for underwriting the subscription of any Shares in, or debentures of the Company, provided that the sanction of the Board is obtained before or within three months of the date on which the contract is entered into.
146. No sanction shall, however, be necessary for:
- (a) any purchase of goods and materials from the Company, or the sale of the goods or materials to the Company, by any such Director, relative, firms partner or private company as aforesaid for cash at prevailing market prices; or
  - (b) any contract or contracts between the Company on one side and any such Director, relative, firm, partner or private company on the other side for sale, purchase or supply of any goods, materials and services in which either the Company or the director, relative, firm, partner or private company, as the case may be, regularly trades or does business, where the value of the goods and materials or the, cost of such services does not exceed Rs. 5,000/-(Rupees five thousand only) in the aggregate in any year comprised in the period of the contract or contracts.
- Notwithstanding the aforesaid, in the circumstances of urgent necessity, a Director, relative, firm, partner or private company as aforesaid may 'without obtaining the consent of the Board enter into any such contract with the Company for the sale, purchase, or supply of any goods, materials or services even if the value of such goods or the cost of such services exceeds Rs. 5,000/(Rupees Five Thousand only), in the aggregate in any year comprised in the period of the contract and the consent of the Board shall be obtained to such contract or contracts at a meeting within three months of the date on which the contract was entered into.
147. A Director of the Company who is in any way, whether directly or indirectly concerned or interested in a contract or proposed contract or arrangement entered into or to be entered into by or on behalf of the Company, shall disclose the nature of his concern or interest at a meeting of the Board in the manner provided in the Act; provided that it shall not be necessary for a Director to disclose his concern or interest in any contract or arrangement entered into or to be entered into with any other company where any of the Directors of the Company either himself or two or more of them together holds or hold not more than two per cent of the paid-up share capital in any such other company.
148. A general notice given to the Board by the Directors, to the effect that he is a director or member of a specified body corporate or is a member of a specified firm and is to be regarded as concerned or interested in any contract or arrangement which may, after the date of the notice, be entered into

- with that body corporate or firm, shall be deemed to be a sufficient disclosure of concern or interest in relation to any contract or arrangement so made. Any such general notice shall expire at the end of the financial year in which it is given but may be renewed for a further period of one financial year at a time by a fresh notice given in the last month of the financial year in which it would have otherwise expired. No such general notice and no renewal thereof, shall be of effect unless it is given at a meeting of the Board, or the Director concerned takes reasonable steps to secure that it is brought up and read at the first meeting of the Board after it is given.
149. No director shall as Director take any part in the discussion of, or vote on any contract or arrangement entered into by or on behalf of the Company, if he is in any way whether directly or indirectly concerned or interested in such contract or arrangement; nor shall his presence count for the purpose of forming a quorum at the time of any such discussion or vote; and if he does vote, his vote shall be void; provided however, that nothing herein contained shall apply to:
- (a) any contract of indemnity against any loss which the Directors or any one or more of them, may suffer by reason of becoming or being sureties or a surety for the Company.
  - (b) any contract or arrangement entered into of to be entered into with a public company or a private company which is a subsidiary of a public company in which the interest of the Director consists solely:
    - (i) In his being:
      - (a) a director in such company, and
      - (b) the holder of not more than Shares of such number or value therein as is requisite to qualify him for appointment as a Director thereof, he having been nominated as such director by the Company or
    - (ii) In his being a member holding not more than 2% of its paid-up share capital.
150. The Company shall keep a register of contracts, companies and firms in which directors are interested and shall within the time specified in the Act enter therein such of the particulars as may be relevant having regard to the application thereto of section 297 or section 299(2) of the Act as the case may be. The register aforesaid shall also specify, in relation to each Director of the Company the names of the bodies corporate and firm of which notice has been given by him under article 148. The register shall be kept at the registered office of the Company and shall be open to inspection at such office, and extracts maybe taken therefrom and copies thereof in the same manner, and on payment of the same fee as in the case of the register of members of the Company.
151. A Director may be or become a director of any company promoted by the Company or in which it may be interested as a vendor, shareholder, or otherwise, and no such director shall be accountable for any benefits received as director or shareholder of such company except in so far as the relevant provisions of the Act maybe applicable.
152. At every Annual General Meeting of the Company, one-third of the Directors for the time being as are liable to retire by rotation or if their number is not three or a multiple of three, the number nearest to one-third shall retire from office.
153. The Directors to retire by rotation under article 152 at every Annual General Meeting shall be those who have been longest in the office since their last appointment, but as between persons who became directors on the same day, those who are to retire, shall, in default of, and subject to any agreement among themselves, be determined by lot.
154. A retiring Director shall be eligible for re-election.
155. Subject to the provisions of the Act, the Company at the General Meeting at which a Director retires in manner aforesaid may fill up the vacated office by electing a person thereto.

156. If the place of the retiring Director is not so filled up and the meeting has not expressly, resolved not to fill the vacancy, the meeting shall stand adjourned until the same day in the next week, at the same time and place.
157. If at the adjourned meeting also, the place of the retiring Director is not filled up and that meeting also has not expressly resolved not to fill the vacancy, the retiring Director shall be so deemed to have been reappointed at the adjourned meeting, unless:
- (i) at that meeting or at the previous meeting the resolution for the reappointment of such Director has been put to the meeting and lost;
  - (ii) the retiring Director has, by a notice in writing addressed to the Company or its Board expressed his unwillingness to be so reappointed;
  - (iii) he is not qualified or is disqualified for appointment;
  - (iv) a resolution whether special or ordinary, is required for the appointment or reappointment by virtue of any provisions of the Act; or
  - (v) the proviso to sub-section (2) of section 263 of the Act is applicable to the case.
158. Subject to the provisions of the Act, the Company may, by a Resolution, from time to time, increase or reduce the number of directors, and may after their qualifications, (subject to the provisions on removal of directors prescribed under the Act) remove any Director before the expiration of his period of office and appoint another qualified person in his stead. The person so appointed shall hold office during such time as the Director in whose place he is appointed would have held the same if he had not been removed.
159. No person not being a retiring Director, shall be eligible for appointment to the office of director at any General Meeting unless he or some Member intending to propose him has, not less than fourteen days before the meeting, left at the registered office of the Company a notice in writing under his hand signifying his candidature for the office of Director or the intention of such Member to propose him as a candidate for that office.
160. Every person (other than a director retiring by rotation or otherwise or a person who has left at the office of the Company a notice as mentioned under article 159 above signifying his candidature for the office of a Director) proposed as a candidate for the office of a Director, shall sign and file with the Company the consent in writing to act as a Director, if appointed.
161. A person other than a Director reappointed after retirement by rotation or immediately on the expiry of his term of office, or an additional or alternate Director, or a person filling a casual vacancy in the office of a Director under section 262 of the Act, appointed as a Director or reappointed as an additional or alternate Director, immediately on the expiry of his term of office shall not act as a Director of the Company unless he has within thirty days of his appointment signed and filed with the Registrar his consent in writing to act as such Director.
162. The Company shall keep at its registered office a register containing the particulars of its Directors, managers, Secretaries and shall otherwise comply with the provisions of the of the Act in this regard in all respects.
163. The Company shall in respect of each of its Directors also keep at its registered office a register of the Directors' shareholdings and details of debentures in the Company and in any other body corporate, being a subsidiary or holding company of the Company, or a subsidiary of the Company's holding company which are held by the Directors or in trust for the Directors, or of which he has any right to become the holder whether on payment or not and shall otherwise duly comply with the provisions of the Act in all respects.
164. Every Director (including a person deemed to be a Director under the provisions of the Act),

Managing Director, manager or Secretary of the Company, shall within twenty days of his appointment to any of the above offices in any other body corporate, disclose to the Company the particulars relating to his office in the other body which are required to be specified under the Act.

165. Every Director and every person deemed to be a Director of the Company under the provisions of the Act, shall give notice to the Company of such matters relating to himself as may be necessary for the purpose of enabling the Company to comply with the provision of section 307 of the Act.

#### **MANAGING DIRECTOR**

166. Subject to the provisions of the Act and of these presents, the Board shall have power to appoint from time to time anyone of its Members as Managing Director of the Company for fixed term not exceeding five years at a time and upon such terms and conditions as the Board thinks fit and subject to the provisions of article 167, the Board may by resolution vest in such Managing Director such of the powers hereby vested in the Board generally as it thinks fit, and such powers may be made exercisable for such period or periods and upon such conditions and subject to such restrictions as it may determine. The remuneration of a Managing Director may be by way of monthly payment, fee for each meeting or participation in profits, or by any or all these modes, or any other mode not expressly prohibited by the Act.
167. The Managing Director shall not exercise the powers to:
- (a) make calls on Share holders in respect of money unpaid on the Shares in the Company.
  - (b) Issue debentures; and except to the extent mentioned in by a resolution passed at a Board meeting, shall also not exercise the powers to:
    - (i) borrow moneys, otherwise than on debentures;
    - (ii) Invest the funds of the Company, and
    - (iii) make loans.
168. The Company shall not appoint or employ, or continue the appointment or employment of a person as its Managing or whole-time Director who:
- (a) is a discharged insolvent, or has at any time been adjudged as insolvent;
  - (b) suspends, or has at any time suspended payment to his creditors, or makes, or has at any time made a composition with them; or
  - (c) is, or has, at any time been convicted by a court of an offence involving moral turpitude.
169. A Managing Director shall not while he continues to hold that office be subject to the retirement by rotation, in accordance with article 152. If he ceases to hold the office of Director, he shall ipso facto and immediately cease to be a Managing Director.

#### **PROCEEDINGS OF THE BOARD OF DIRECTORS**

170. The Directors may meet together as a Board for the despatch of business from time to time, and shall so meet at least once in every three months and at least four such meetings shall be held in every year. The Directors may adjourn and otherwise regulate their meetings as they think fit.
171. Notice of every meeting of the Board shall be given in writing to every Director for the time being in India, and at his usual address in India to every other Director.
172. The Secretary shall, as and when directed by the Directors to do so convene a meeting of the Board by giving a notice in writing to every other Director.

173. The Board shall appoint a chairman of its meetings and determine the period for which he is to hold office. If no chairman is appointed, or if at any meeting of the Board the chairman is not present within five minutes after the time appointed, for holding the same, the Directors present shall choose some one of their member to be the chairman of such meeting.
174. The quorum for a meeting of the Board shall be determined from time to time in accordance with the provisions of the Act. If a quorum shall not be present within fifteen minutes from the time appointed for holding a meeting of the Board it shall be adjourned until such date and time as the chairman of the Board shall decide.
175. A meeting of the Board of which a quorum be present shall be competent to exercise all or any of the authorities powers and discretions by or under these presents for the time being vested in or exercisable by the Board.
176. Subject to the provisions of the Act, questions arising at any meeting shall be decided by a majority of votes, and in case of any equality of votes, the Chairman shall have a second or casting vote.
177. The Board may subject to the provisions of the Act, from time to time and at any time delegate any of its powers to a committee consisting of such Director or Directors as it thinks fit, and may from time to time revoke such delegation. Any committee so formed shall, in the exercise of the powers so delegated, conform to any regulation that may from time to time be imposed upon it by the Board.
178. The meetings and the proceedings of any such committee consisting of two or more members shall be governed by the provisions herein contained for regulating the meetings and proceedings of the Board so far as the same are applicable thereto, and are not superseded by any regulations made by the Board under the article 177.
179. Save in those case where a resolution is required under the provisions of the Act, to be passed at a meeting of the Board, a resolution shall be as valid and effectual as if it had been passed at a meeting of the Board or committee of the Board, as the case may be, duly called and constituted, if a draft thereof in writing is circulated, together with the necessary papers, if any, to all the Directors, or to all the members of the committee of the Board, as the case may be, then in India (not being less in number than the quorum fixed for a meeting of the Board or committee, as the case may be) and to all other Directors, or members of the committee, at their usual address in India, and has been approved by such of them as are then in India, or by a majority of them as are entitled to vote on the resolution.
180. All acts done by any meeting of the Board or by a committee of the Board or by any person acting as a Director shall notwithstanding that it shall afterwards be discovered that there was some defect in the appointment of such Director or persons acting as aforesaid, or that they or any of them were disqualified or had vacated office or that the appointment of any of them had been terminated by virtue of any provisions contained in the Act or in these presents, be as valid as if every such person had been duly appointed, and was qualified to be a Director and had not vacated his office or his appointment had not been terminated; Provided that nothing in this article shall be deemed to give validity to acts done by a Director after his appointment has been shown to the Company to be invalid or to have been terminated.
181. The Company shall cause minutes of all proceedings of every meeting of the Board and committee thereof to be kept by making within thirty days of the conclusion of every such meeting entries thereof in the books kept for that purpose with their pages consecutively numbered.
182. Each page of every such book shall be initialed or signed and the last page of the record of proceedings of each meeting in such book shall be dated and signed by the chairman of the said meeting or the chairman of the next.

183. In no case shall the minutes of proceedings of the meetings of the Board be attached to any such book as aforesaid by a pasting or otherwise.
184. The minutes of each meeting shall contain a fair and correct summary of the proceedings thereat.
185. All appointments of officers made at any of the meetings aforesaid shall be included in the minutes of the meetings.
186. The minutes shall also contain:
- (a) the names of the Directors present at the meeting; and
  - (b) in the case of each resolution passed at the meeting the names of the Directors, if any, dissenting from or not concurring in the resolution.
187. Nothing contained in articles 181 to 186 shall be deemed to require the inclusion in any such minutes of any matter which, in the opinion of the chairman of the meeting:
- (a) is, or could reasonably be regarded as defamatory of any person.
  - (b) is irrelevant or immaterial to the proceedings; or
  - (c) is detrimental to the interest of the Company.

The chairman shall exercise an absolute discretion in regard to the inclusion or non-inclusion of any matter in the minutes on the grounds specified in this article.

188. Minutes of meetings kept in accordance with the aforesaid provisions shall be evidence of the proceedings recorded therein.
189. The Board may exercise all such powers of the Company and do all such acts, and things as are not, by the Act, or any other law, or by the Memorandum, or by the Articles of Association of the Company, required to be exercised by the Company in a General Meeting subject nevertheless to these presents, to the provisions of the Act, or any other law and to such regulations being not inconsistent with the aforesaid regulations or provisions, as may be prescribed by the Company in a General Meeting but no regulations made by the Company in a General Meeting shall invalidate any prior act of the Board which would have been valid if that regulation had not been made. Provided that the Board shall not, except with the consent of the Company in General Meeting:
- (a) sell, lease or otherwise dispose of the whole, or substantially the whole of the undertaking of the Company, or where the Company owns more than one undertaking, the whole, or substantially the whole of any such undertaking.
  - (b) remit, or give time for the repayment of any debt due by a Director.
  - (c) invest, otherwise than in trust securities, the amount of compensation received by the Company in respect of the compulsory acquisition of any such undertaking as is referred to in (a) above, or of any premises or properties used for any such undertaking and without which it cannot be carried on or can be carried on only with difficulty or only after a considerable time.
  - (d) borrow moneys where the moneys to be borrowed together with the moneys already borrowed by the Company (apart from temporary loans obtained from the Company's bankers in the ordinary course of business), will exceed the aggregate of the paid up capital of the Company and its free reserves that is to say, reserve not set apart for any specific purpose.
  - (e) contribute to charitable and other funds not directly relating to the business of the

Company or the welfare of its employees, any amounts the aggregate of which will, in any financial year, exceed fifty thousand rupees or five per cent of its average net profits as determined in accordance with the provisions of sections 349 and 350 of the Act during the three financial years immediately preceding, whichever is greater.

190. Subject to the provisions of the Act and without prejudice to the general powers conferred by the last preceding article and so as not in any way to limit or restrict those powers, and without prejudice to the other powers conferred by these articles, but subject to the restrictions contained in the last preceding article, it is hereby declared that the Directors shall have the following powers; that is to say, power
- (1) To pay the costs, charges and expenses preliminary and incidental to the promotion, formation, establishment and registration of the Company.
  - (2) To charge to the capital account of the Company any interest lawfully payable under the provisions of the Act.
  - (3) Subject to the provisions of the Act to purchase or otherwise acquire for the Company any property, rights or privileges which the Company is authorized to acquire, at or for such price or consideration and generally on such terms and conditions as they may think fit and in any such purchase or other acquisition to accept such title as the Directors may believe or may be advised to be reasonably satisfactory;
  - (4) At their discretion and subject to the provisions of the Act to pay for any property, rights or privileges acquired by or services rendered to the Company, either wholly or partially, in Shares, bonds, debentures, mortgages, or other securities of the Company, and such Shares may be issued either as fully paid up or with such amount credited as paid up thereon as may be agreed upon all or any part of the property of the Company and its uncalled capital or not so charged;
  - (5) To secure the fulfillment of any contracts or engagement entered into by the Company by mortgage or charge of all or any of the property of the Company and its uncalled capital for the time being or in such manner as they may think fit;
  - (6) To accept from any Member, as far as may be permissible by law, a surrender of his Shares or any part thereof, on such terms and conditions as shall be agreed;
  - (7) To appoint any person to accept and hold in trust for the Company, and property belonging to the Company, in which it is interested, or for any other purposes; and execute such deeds and do all such things as may be required in relation to any trust, and to provide for the remuneration of such trustee or trustees;
  - (8) To institute, conduct, defend, compound or abandon any legal proceedings by or against the Company or its officers, or otherwise concerning the affairs of the Company, and also to compound and allow time for payment or satisfaction of any debts due, and of any claim or demands by or against the Company and to refer any differences to arbitration, and observe and, perform any awards made thereon;
  - (9) To act on behalf of the Company in all matters relating to bankrupts and insolvents;
  - (10) To make and give receipts, releases and other discharges for moneys payable to the Company and for the claims and demands of the Company;
  - (11) Subject to the provisions of the Act, to invest and deal with any moneys of the Company not immediately required for the purpose thereof upon such security (not being Shares of this Company), or without security and in such manner as they think fit, and from time to time to vary the size of such investments. Save as provided in the Act, all investments

shall be made and held in the Company's own name;

- (12) To execute in the name and on behalf of the Company in favour of any Director or other person who may incur or be about to incur any personal liability whether as principal or surety, for the benefit of the Company, such mortgages of the Company's property (present or future) as they think fit, and any such mortgage may contain a power of sale and such other powers, provisions, covenants and agreements as shall be agreed upon;
- (13) To determine from time to time who shall be entitled to sign, on the Company's behalf, bills, notes, receipts, acceptances, endorsements, cheques, dividends, warrants, releases, contracts and documents and to give the necessary authority for such purpose;
- (14) To distribute by way of bonus amongst the staff of the Company, Share or Shares in the profits of the Company, and to give to any officer or other person employed by the Company a commission on the profits of any particular business or transaction; and to charge such bonus or commission as part of the working expenses of the Company;
- (15) To provide for the welfare of Directors or ex-Directors or employees or ex-employees of the Company and their wives, widows and families or the dependents or connections of such persons by building or contributing to the building of houses, dwellings or by grants of money, pension, gratuities, allowances, bonus or other payments, or by creating and from time to time subscribing or contributing to provident and other associations, institutions, funds or trusts and by providing or subscribing or contributing towards places of recreation, hospitals and dispensaries, medical and other attendance and other assistance as the Board shall think fit and to subscribe or contribute or otherwise to assist or to guarantee money to charitable, benevolent, religious, scientific, national or other institutions or objects which shall have any moral or other claim to support or aid by the Company, either by reason of locality of operation, or of public and general utility or otherwise;
- (16) Before recommending any dividend, to set aside out of the profits of the Company such sums as they may think proper for depreciation or to a depreciation fund, or to an insurance fund, or as to a reserve fund, or sinking fund, or any special fund to meet contingencies or to repay Debentures or Debenture stock, or for special dividends or for equalized dividends or for repairing, improving, extending and maintaining any of the property of the Company and for such other purpose (including the purposes referred to in the preceding article), as the Board may, in their absolute discretion, think conducive to the interest of the Company, and subject to the provisions of the Act, to invest the several sums so set aside or so much thereof as required to be invested upon such investments (other than Shares of the Company) as they may think fit, and from time to time to deal with and vary such investments and dispose of the same and apply and expand all or any part thereof for the benefit of the Company, in such manner and for such purpose as the Board in their absolute discretion think conducive to the interest of the Company, notwithstanding that the matters to which the Board apply or upon which they expend the same, or any part thereof, may be matters to or upon which the capital moneys of the Company might rightly be applied or expended; and to divide the reserve fund into such special funds as the Board may think fit, with full power to transfer the whole, or any portion of a reserve fund or division of a reserve fund to another reserve fund or division of a reserve fund and with full power to employ the assets constituting all or any of the above funds, including the depreciation fund, in the business of the Company or in the purchase or repayment of Debentures or debenture-stock, and without being bound to keep the same separate from the other assets, and without being bound to pay interest on the same with power, however, to the Board at their discretion to pay or allow to the credit of such funds interest at such rate as the Board may think proper.
- (17) Subject to the provisions of the Act to appoint, and at their discretion remove or suspend such general managers, managers, secretaries, assistants, supervisor, clerks, agents and

servants of permanent, temporary or special services as they may from time to time think fit, and to determine their powers and duties and fix their salaries or emoluments or remuneration, and to require security in such instances and to such amount as they may think fit. Also, from time to time provide for the management and transaction of the affairs of the Company in any specified locality in India, or elsewhere in such manner as they think fit; and the provisions contained in the four next following sub-articles shall be without prejudice to the general powers conferred by this sub-article.

- (18) To comply with the requirements of any local law which in their opinion it shall, in the interest of the Company, be necessary and deem expedient to comply with.
- (19) From time to time and at any time to establish any local board or committee for managing any of the affairs of the Company in any specified locality in India or elsewhere and to appoint any persons to the members of such local boards or committees and to fix their remuneration.
- (20) Subject to the provisions of the Act, from time to time and at any time, delegate to any person so appointed any of the powers, authorities and discretion for the time being vested in the Board, other than their power to make calls or to make loans or borrow moneys, and to authorise the members for the time being of any such local board or committee, or any of them to fill up any vacancies therein and to act notwithstanding vacancies, and any such appointment or delegation may be made on such terms and subject to such conditions as the Board may think fit, and the Board may at any time remove any person so appointed, and may annul or vary any such delegation.
- (21) At any time and from time to time by power of attorney under the seal of the Company, to appoint any person or persons to be the attorney or attorneys of the Company, for such purposes and with such powers, authorities and discretion (not exceeding those vested in or exercisable by the Board under these presents and excluding the powers to make calls and excluding also, except in their limits authorised by the Board, the power to make loans and borrow moneys) and for such period and subject to such conditions as the Board may from time to time think fit and any such appointment may (if the Board thinks fit) be made in favour of the members or any of the members of any local board or committee, established as aforesaid or in favour of any company, or the Share holders, directors, nominees or managers of any company or firm or otherwise in favour of any fluctuating body of persons whether nominated directly by the Board and any such power of attorney may contain such powers for the protection or convenience of persons dealing with such attorneys as the Board may think fit and may contain powers enabling any such delegates or attorneys as aforesaid to sub-delegate all or any of the powers, authorities and discretions for the time being vested in them.
- (22) Subject to the provisions of the Act, for or in relation to any of the matters aforesaid or otherwise for the purposes of the Company to enter into all such contracts, and to execute and do all such acts, deeds and things in the name and on behalf of the Company as they may consider expedient.
- (23) Subject to the provisions of the Act, the Board may pay such remuneration to chairman / vice chairman of the Board upon such conditions as they may think fit.

#### **THE SECRETARY**

191. The Directors may from time to time appoint, and at their discretion, remove the Secretary provided that where the Board comprises of only three Directors, neither of them shall be the Secretary. The Secretary appointed by the directors pursuant to this article shall be a whole-time Secretary. The Directors may also at any time appoint some person, who need not be Secretary, to keep the registers required to be kept by the Company.

## **THE SEAL**

192. The Board shall provide a common seal for the purposes of the Company, and shall have power from time to time to destroy the same and substitute a new Seal in lieu thereof and the seal shall never be used except by the authority of the Board or a committee of the Board previously given.
193. The Company shall also be at liberty to have an official Seal for use in any territory, district or place outside India.
194. Every deed or other instrument, to which the seal of the Company is required to be affixed, shall unless the same is executed by a duly constituted attorney, be signed by two Directors or one Director and Secretary or some other person appointed by the Board for the purpose, provided that in respect of share certificates, the Seal shall be affixed in accordance with the article 19.

## **DIVIDENDS**

195. The profits of the Company, subject to any special rights relating thereto created or authorized to be created by these articles, and subject to the provisions of these articles shall be divisible among the members in proportion to the amount of capital paid-up on the Shares held by them respectively.
196. The Company in General Meeting may declare dividends to be paid to members according to their respective rights, but no dividend shall exceed the amount recommended by the Board, but the Company in General Meeting may declare a smaller dividend.
197. No dividend shall be declared or paid otherwise than out of the profits of the financial year arrived at after providing for depreciation in accordance, with the provisions of the Act or out of the profits of the Company for any previous financial year or years arrived at after providing for depreciation in accordance with these provisions and remaining undistributed or out of both, provided that:
  - (a) if the Company has not provided for depreciation for any previous financial year or years, it shall, before declaring or paying a dividend for any financial year, provide for such depreciation out of the profits of the financial year or years.
  - (b) if the Company has incurred any loss in any previous financial year or years, the amount of the loss or any amount which is equal to the amount provided for depreciation for that year or those years whichever is less, shall be set off against the profits or the company for the year for which the dividend is proposed to be declared or paid or against the profits of the Company for any previous financial year or years arrived at in both cases after providing for depreciation in accordance with the provisions of sub-section (2) of section 205 of the Act, or against both.
198. The Board may, from time to time, pay to the Members such interim dividend as in their judgment, the position of the Company justifies.
199. Where capital is paid in advance of calls, such capital may carry interest but shall not in respect thereof confer a right to dividend or participate in profits.
200. All dividends shall be apportioned and paid proportionately to the amounts paid or credited as paid on the Shares during any portion or portions of the period in respect of which the dividend is paid, but if any Share is issued on terms providing that it shall rank for dividend as from a particular date, such Share shall rank for dividend accordingly.
201. The Board may retain the dividends payable upon Shares in respect of which any person is under the article 73 entitled to become a member or which any person under that article is entitled to transfer; until such a person shall become a member, in respect of such Shares or duly transfer the same.

202. Anyone of several persons who are registered as joint-holders of any Share may give effectual receipts for all dividends or bonus and payments on account of dividends or bonus or other moneys payable in respect of such Shares.
203. No Member shall be entitled to receive payments of any interest or dividend in respect of his Share or Shares, while any money may be due or owing from him to the Company in respect of such Share or Shares or otherwise howsoever, either alone or jointly with any other person or persons and the Board may deduct from the interest or dividend payable to any member all sums of money so due from him to the Company.
204. A transfer of Share shall not pass the right to any dividend declared thereon before the registration of the transfer.
205. Unless otherwise directed, any dividend may be paid by cheque or warrant or by a pay-slip or receipt having the force of a cheque or warrant sent through the post to the registered address of the Member or person entitled or in case of joint-holders to that one of them first named in the register in respect of the joint-holdings. Every such cheque or warrant shall be made payable to the order of the person to whom it is sent. The Company shall not be liable or responsible for any cheque or warrant or pay-slip or receipt lost in transmission, or for any dividend lost to the Member or person entitled thereto by the forged endorsement of any cheque or warrant or the forged signature of any pay-slip or receipt or the fraudulent recovery of the dividend by any other means.
206. Where the Company has declared a dividend but which has not been paid or the dividend warrant in respect thereof has not been posted within 30 days from the date of declaration to any shareholder entitled to the payment of the dividend, the Company shall within 7 days from the date of expiry of the said period of 30 days, open a special account in that behalf in any scheduled bank called "Unpaid Dividend of Adhunik Metaliks Limited" and transfer to the said account, the total amount of dividend which remains unpaid or in relation to which no dividend warrant has been posted.

Any money transferred to the unpaid dividend account of the Company which remains unpaid or unclaimed for a period of seven years from the date of such transfer, shall be transferred by the Company to the fund established under the Act by the Central Government known as the Investor Education and Protection Fund. No unclaimed dividend shall be forfeited by the Board and the Company shall comply with the provisions of the Act in respect of all unclaimed or unpaid dividends.

207. Any General Meeting declaring a dividend may, on the recommendation of the Directors, make a call on the members of such amount as the meeting fixes, but so that the call on each Member shall not exceed the dividend and the dividend may, if so arranged between the Company and the Member, be set off against the calls.

#### **CAPITALISATION OF RESERVES**

208. The Company upon the recommendation of the Board in any General Meeting may resolve that any moneys, investments, or other assets forming part of undivided profits of the Company standing to the credit of the reserves, or any capital redemption reserve fund, in the hands of the Company and available for dividend or representing premiums received on the issue of Shares and standing to the credit of the share premium account be capitalised and distributed amongst such of the members as would be entitled to receive the same if distributed by way of dividend in the same proportions and on the footing that they become entitled thereto as capital and that all or any part of such capital fund be applied on behalf of such members in paying up in full any unissued Shares, debentures, or debenture-stock of the Company which shall be distributed accordingly or in or towards payment of the uncalled liability on any issued shares, that such distribution or payment shall be accepted by such Members in full satisfaction of their interest in the said capitalised sum. Provided that any sum standing to the credit of a share premium account or a capital redemption reserve fund may, for the purposes of this article, only be applied in the paying

up of unissued Shares to be issued to Members of the Company as fully paid bonus Shares.

209. A General Meeting may resolve that any surplus money arising from the realisation of any capital asset of the Company or any investments representing the same, or any other undistributed profits of the Company not subject to charge for income tax, be distributed among the members on the footing that they receive the same as capital.
210. For the purpose of giving effect to any resolution under the two last preceding articles hereof the Board may settle any difficulty which may arise with regard to the distribution as it thinks expedient and in particular may issue fractional certificates, and may fix the value of distribution of any specific assets and may determine that cash payment shall be made to any Members upon the footing of the value so fixed in order to adjust the rights of all parties and may vest such cash or specific assets in trustees upon such trusts for the persons entitled to the Board. Where requisite, a proper contract shall be filed with the Registrar in accordance with the provisions of the Act, and the Board may appoint any person to sign such contract on behalf of the person entitled to the dividend or capital fund, and such appointment shall be effective.

### **ACCOUNTS**

211. The Company shall keep at the registered office or at such other place in India as the Board thinks fit, proper books of accounts with respect to:
- (a) all the sums of moneys received and expended by the Company and the matters in respect of which the receipts and expenditure take place.
  - (b) all sales and purchases of goods by the Company.
  - (c) the assets and liabilities of the Company.
212. Where the Board decides to keep all or any of the books of account at any place other than the registered office of the Company, the Company shall within seven days of the decision file with the Registrar a notice in writing giving, the full address of that other place.
213. The Company shall preserve in good order the books of account relating to the period of not less than eight years preceding the current year together with the vouchers relevant to any entry in such books of account.
214. Where the Company has a branch office, whether in or outside India, the Company shall be deemed to have complied with this article if proper books of account relating to the transactions effected at the branch office are kept at the branch office and proper summarized returns made up to date at intervals of not more than three months are sent by the branch office to the Company at its registered office or at other place in India, at which the Company's books of account are kept as aforesaid.
215. The books of account shall give a true and fair view of the state of affairs of the Company or branch office, as the case may be, and explain its transactions. The books of account and other books and papers shall be open to inspection by any Directors during business hours.
216. The Board shall from time to time determine whether and to what extent and at what times and place and under what conditions are regulations the accounts and books of the Company or any of them shall be open to the inspection of Members not being Directors, and no person (not being a Member) shall have any right of inspecting any right of inspecting any account or books or document of the Company except as conferred by law or authorized by the Board.
217. The Directors shall from time to time, cause to be prepared and to be laid before the Company in General Meeting, such balance sheets, profit and loss account and reports as are required by the provisions of the Act.
218. A copy of every such profit and loss account and balance sheet (including the auditors report and

every other document required by law to be annexed or attached to the balance sheet), shall at least twenty-one days before the meeting at which the same are to be laid before the Members, be sent to the Members of the Company, to holders of debentures issued by the Company (not being debentures which ex facie are payable to the bearer thereof); to trustees for the holders of such debentures and to all persons entitled to receive notice of General Meeting of the Company.

#### **AUDIT**

219. Statutory auditors, shall be appointed and their rights and Duties regulated in accordance with the provisions of the Act.
220. The first auditor or auditors of the Company shall be appointed by the Board within one month or the date of registration of the Company and the auditor or auditors so appointed shall hold office until the conclusion of the first Annual General Meeting provided that the Company may, at a General Meeting, remove any such auditor or all or such auditors and appoint in his or their place any other person or persons who have been nominated for appointment by any Member of the Company and of whose nomination notice has been given to the Members of the company not less than fourteen days before the date of the Meeting provided further that if the Board fails to exercise its powers under this article, the Company in General Meeting may appoint the first auditor or auditors.

The aforesaid provisions shall mutatis mutandis apply to any secretarial auditor appointed under the relevant provisions of the Act.

#### **DOCUMENTS AND NOTICES**

221. A document or notice may be served or given by the Company on any Member either personally or sending it by post to him to his registered address or (if he has no registered address in India) to the address, if any, in India supplied by him to the Company for serving documents or notices on him.
222. Where a document or notice is sent by post, services of the document or notice shall be deemed to be effected by properly addressing, prepaying and posting a letter containing the document or notice, provided that where a Member has intimated to the Company in advance that documents or notices should be sent to him under a certificate of posting or by registered post with or without acknowledgment due and has deposited with the Company a sum sufficient to defray the expenses of the doing so; service of the documents or notice shall not be deemed to be effected unless it is sent in the manner intimated by the Member and such service shall be deemed to have been effected in the case of notice of a meeting, at the expiration of forty-eight hours after the letter containing the document or notice is posted and in any other case at the time at which the letter would be delivered in the ordinary course of post.
223. A document or notice advertised in a newspaper circulating in the neighborhood of the registered office shall be deemed to be duly served or sent on the day on which the advertisement appears to every Member who has no registered address in India and has not supplied to the Company an address within India for serving of documents on or the sending of notices to him.
224. A document or notice may be served or given by the Company on or given to the joint-holders of a Share by serving or giving the document or notice on or to the joint-holders named first in the register of members in respect of the Shares.
225. A document or notice may be served or given by the Company on or to the persons entitled to a Share in consequence of the death or insolvency of a Member by sending it through post in a prepaid letter addressed to him or them by name or by the title of representatives of the deceased or assignee of the insolvent or by any like description, at the address (if any) in India supplied for the purpose, by the persons claiming to be entitled, or (until such an address has been so supplied) by serving the document or notice in any manner in which the same might have been given if the death or insolvency had not occurred.

226. Documents or notices of every General Meeting shall be served or given in the same manner hereinbefore on or to (a) every member (b) every person entitled to a Share in consequence of the death or insolvency of a member, and (c) the auditor for the time being of the Company.
227. Every person who, by operation of law, transfer or other means whatsoever, shall become entitled to any Share, shall be bound by every document or notice in respect of such Shares, prior to his name and address being entered on the register of members, which have been duly served on or given to the person from whom he derives his title to such Shares.
228. Any document or notice to be served or given by the Company may be signed by a Director or some person duly authorised by the Board of Directors for such purpose and the signatures thereto may be written printed or lithographed.
229. All documents or notices, to be served or given by members on or to the Company or any office thereof shall be served or given by sending it to the Company or officer at the registered office by post under a certificate of posting or by registered post, or by leaving it at the office.

#### **WINDING UP**

230. The liquidator on any winding-up (whether voluntary or compulsory) may, with the sanction of a Special Resolution but subject to the rights attached to any preference share capital, divide among the contributories any part of the assets of the Company and may with the like sanction; vest any part of the assets of the Company in trustees upon such trusts for the benefit of the contributories as the liquidator, with the like sanction shall think fit.

#### **INDEMNITY AND RESPONSIBILITY**

231. Every officer or agent for the time being of the Company shall be indemnified out of the assets of the Company against all liability incurred by him in defending any proceeding, whether civil or criminal in which judgment is given in his favour or in which he is acquitted or discharged or in connection with any application under section 633 of Act, in which relief is granted to him by the Court.

#### **SECRECY**

Subject to the provisions of these articles and the Act no member, or other person (not being a Director) shall be entitled to enter the property of the Company or to inspect or examine the Company's premises or properties of the Company without the permission of the Directors or to require discovery of or any information respecting any detail of the Company's trading or any matter which is or may be in the nature or a trade secret, mystery of trade, or secret process or of any matter whatsoever which may relate to the conduct of the business of the Company and which in the opinion of the Directors will be inexpedient in the interest of the Company to communicate.

## **MATERIAL CONTRACTS AND DOCUMENTS FOR INSPECTION**

The following contracts (not being contracts entered into in the ordinary course of business carried on by our Company or entered into more than two years before the date of this Prospectus) which are or may be deemed material have been entered or to be entered into by us. These contracts, copies of which have been attached to the copy of the Prospectus, delivered to the ROC for registration and also the documents for inspection referred to hereunder, may be inspected at the corporate office of our Company situated at 6<sup>th</sup> Floor Landsdowne Towers, 2/1A, Sarat Bose Road, Kolkata 700 020 from 10.00 am to 4.00 pm on working days from the date of the Prospectus until the Bid/Issue Closing Date.

### **Material Contracts**

1. Letter of appointment from our Company appointing SBI Capital Markets Limited and Karvy Investor Services Limited as the Book Running Lead Manager and their acceptance thereto.
2. Memorandum of Understanding between our Company and the Book Running Lead Managers.
3. Memorandum of Understanding executed by our Company with Registrar to the Issue being Karvy Computershare Private Limited.
4. Escrow Agreement dated February 24, 2006 between our Company, the Book Running Lead Managers, Escrow Collection Banks, and the Registrar to the Issue.
5. Syndicate Agreement dated February 24, 2006 between our Company, the Book Running Lead Manager and Syndicate Members.
6. Underwriting Agreement dated March 23, 2006 between our Company, the BRLMs and the Syndicate Members.
7. Employment Agreement dated March 16, 2004 between the Company and Mr. Manoj Kumar Agarwal, our Managing Director.
8. Order dated April 11, 2005 passed by the Hon'ble Calcutta High Court in the matter of the Scheme of Amalgamation between Neepaz Metaliks Limited (now known as Adhunik Metaliks Limited) and Adhunik Minerals & Alloys Limited

### **Documents for Inspection**

1. Our Memorandum and Articles of Association as amended till date.
2. Our fresh certificate of incorporation dated March 25, 2004 and August 9, 2005.
3. Shareholders' resolutions dated July 22, 2005 in relation to this Issue and other related matters.
4. Resolutions of the Board dated December 19, 2005 approving the Issue.
5. Resolutions of the general body for appointment and remuneration of our whole-time Directors dated March 15, 2004.
6. Report of the Auditors, M/s S.R. Batliboi & Co., Chartered Accountants, prepared as per Indian GAAP and mentioned in this Prospectus.
7. Copies of annual reports of our Company.

8. Consents of the Auditors, Chartered Accountants, for inclusion of their report on accounts in the form and context in which they appear in this Prospectus.
9. General powers of attorney executed by the Directors in favour of person(s) for signing and making necessary changes to this Prospectus and other related documents.
10. Consents of Auditors, Bankers to the Company, BRLMs, Syndicate Members, Registrar to the Issue, Escrow Collection Bank(s), Banker to the Issue, Legal Counsel to the Issue, our Directors, Company Secretary and Compliance Officer, as referred to, in their respective capacities.
11. Copies of the following Sanction Letter(s) for financing the debt required for the project.

Letter No.	Date	Name of the Bank	Sanctioned Amt
Nil	December 30, 2005	Punjab National Bank	75.00
I0B/IEP/015	20/12/2005	Indian Overseas Bank	50.00
KMO/CAD/2005-06/02/795	February 17, 2006	Central Bank of India	45.00
IFB:KOL:793:05	16-01-06	Union Bank of India	35.00
AGM/ADV/2005-06	06.01.2006	UCO Bank	30.00
KMO/ADV/70/086	1 <sup>st</sup> Feb. 2006	Bank of Baroda	30.00
CMK/9591/ADV/722/05	31/12/2005	Syndicate Bank	25.00
DGM/CHE/SNS/AML	30.12.2005	State Bank of Travancore	25.00
aml/229	24/01/2006	State Bank of Mysore	20.00
-	17/01/2006	Oriental Bank of Commerce	20.00
DB1:ADV:BNC	20.12.2005	Bank of India	20.00
CAL/GEN/43/2005-06	14/02/2006	Lakshmi Vilas bank	15.00

12. Appraisal Report of SBI Capital Markets Ltd.
13. Tax benefit report from our Company's Statutory Auditors
14. In-principle listing approval dated February 10, 2006 and February 7, 2006 from the NSE and the BSE respectively.
15. Tripartite agreement between NSDL, Company and the Registrar to the Issue dated February 20, 2006.
16. Tripartite agreement between CDSL, our Company and the Registrar to the Issue dated February 21, 2006.
17. Due diligence certificate dated January 9, 2006 submitted to SEBI by SBI Capital Markets Ltd. and Karvy Investor Services Ltd.
18. Copy of SEBI observation letter no. CFD/DIL/ISSUES/PB/MKS/61103/2006 dated February 23, 2006.
19. Consent letter dated February 2, 2006 from State Bank of India to act as Monitoring Agency.

Any of the contracts or documents mentioned in this Prospectus may be amended or modified at any time if so required in the interest of us or if required by the other parties, without reference to the shareholders subject to compliance of the provisions contained in the Companies Act and other relevant statutes.

## DECLARATION

All the relevant provisions of the Companies Act 1956, and the guidelines issued by the Government of India or the guidelines issued by the Securities and Exchange Board of India, established under Section 3 of the Securities and Exchange Board of India Act, 1992, as the case may be, have been complied with and no statement made in this Prospectus is contrary to the provisions of the Companies Act, 1956, the Securities and Exchange Board of India Act, 1992 or rules made thereunder or guidelines issued, as the case may be.

We and the signatories mentioned below further certify that all statements in this Prospectus are true and correct.

### SIGNED BY ALL DIRECTORS

Manoj Kumar Agarwal \*

Ghanshyam Das Agarwal \*

Jugal Kishore Agarwal \*

Mahesh Kumar Agarwal \*

Mohan Lal Agarwal \*

Nirmal Kumar Agarwal \*

Nihar Ranjan Hota \*

Supriya Gupta \*

Lalit Mohan Chatterjee \*

Alok Kumar Sharda \*  
(Chief Financial Officer)

\* through their constituted Attorney, Mr. Sougata Sengupta, Company Secretary and Compliance Officer

Date: March 27, 2006.

Place: Kolkata

THIS PAGE HAS BEEN INTENTIONALLY LEFT BLANK

THIS PAGE HAS BEEN INTENTIONALLY LEFT BLANK

THIS PAGE HAS BEEN INTENTIONALLY LEFT BLANK

|